

**TRACY HILLS SPECIFIC PLAN
DRAFT SUBSEQUENT ENVIRONMENTAL IMPACT REPORT
VOLUME II
DECEMBER 2014**

**APPENDIX H-1a
EXISTING COUNTS – TRACY, DATED SPRING & FALL 2013, SPRING
2014**

ALL TRAFFIC DATA

City of Tracy
 All Vehicles on Unshifted
 Buses on Bank 1
 FHWA Class 5 and above on Bank 2

(916) 771-8700
orders@atdtraffic.com

File Name : 13-7322-001 Corral Hollow Road-I-580 EB Ramps.ppd
 Date : 5/22/2013

Unshifted Count = All Vehicles

START TIME	Corral Hollow Road Southbound					I-580 EB Ramps Westbound					Corral Hollow Road Northbound					I-580 EB Ramps Eastbound					Total	Utum Total
	LEFT	THRU	RIGHT	UTURNS	APP.TOTAL	LEFT	THRU	RIGHT	UTURNS	APP.TOTAL	LEFT	THRU	RIGHT	UTURNS	APP.TOTAL	LEFT	THRU	RIGHT	UTURNS	APP.TOTAL		
07:00	8	94	0	0	102	0	0	0	0	0	0	1	1	0	2	8	0	5	0	13	117	0
07:15	9	63	0	0	72	0	0	0	0	0	0	2	1	0	3	11	0	1	0	12	87	0
07:30	10	39	0	0	49	0	0	0	0	0	0	3	1	0	4	8	0	4	0	12	65	0
07:45	8	34	0	0	42	0	0	0	0	0	0	2	1	0	3	18	2	1	0	21	66	0
Total	35	230	0	0	265	0	0	0	0	0	0	8	4	0	12	45	2	11	0	58	335	0
08:00	9	25	0	0	34	0	0	0	0	0	0	2	0	0	2	11	1	1	0	13	49	0
08:15	6	32	0	0	38	0	0	0	0	0	0	3	0	0	3	15	0	1	0	16	57	0
08:30	22	20	0	0	42	0	0	0	0	0	0	2	1	0	3	12	1	3	0	16	61	0
08:45	12	20	0	0	32	0	0	0	0	0	0	1	1	0	2	11	0	1	0	12	46	0
Total	49	97	0	0	146	0	0	0	0	0	0	8	2	0	10	49	2	6	0	57	213	0
16:00	25	4	0	0	29	0	0	0	0	0	0	36	48	0	84	47	0	1	0	48	161	0
16:15	17	4	0	0	21	0	0	0	0	0	0	30	42	0	72	53	0	0	0	53	146	0
16:30	20	1	0	0	21	0	0	0	0	0	0	17	47	0	64	67	0	0	0	67	152	0
16:45	16	1	0	0	17	0	0	0	0	0	0	30	66	0	96	63	0	1	0	64	177	0
Total	78	10	0	0	88	0	0	0	0	0	0	113	203	0	316	230	0	2	0	232	636	0
17:00	17	5	0	0	22	0	0	0	0	0	0	29	57	0	86	57	0	3	0	60	168	0
17:15	24	4	0	0	28	0	0	0	0	0	0	49	61	0	110	66	0	0	0	66	204	0
17:30	26	1	0	0	27	0	0	0	0	0	0	65	57	0	122	70	1	1	0	72	221	0
17:45	15	2	0	0	17	0	0	0	0	0	0	42	68	0	110	64	1	0	0	65	192	0
Total	82	12	0	0	94	0	0	0	0	0	0	185	243	0	428	257	2	4	0	263	785	0
Grand Total	244	349	0	0	593	0	0	0	0	0	0	314	452	0	766	581	6	23	0	610	1969	0
Approch %	41.1%	58.9%	0.0%	0.0%		0.0%	0.0%	0.0%	0.0%		0.0%	41.0%	59.0%	0.0%		95.2%	1.0%	3.8%	0.0%			
Total %	12.4%	17.7%	0.0%	0.0%	30.1%	0.0%	0.0%	0.0%	0.0%	0.0%	0.0%	15.9%	23.0%	0.0%	38.9%	29.5%	0.3%	1.2%	0.0%	31.0%	100.0%	

AM PEAK HOUR	Corral Hollow Road Southbound					I-580 EB Ramps Westbound					Corral Hollow Road Northbound					I-580 EB Ramps Eastbound					Total
	LEFT	THRU	RIGHT	UTURNS	APP.TOTAL	LEFT	THRU	RIGHT	UTURNS	APP.TOTAL	LEFT	THRU	RIGHT	UTURNS	APP.TOTAL	LEFT	THRU	RIGHT	UTURNS	APP.TOTAL	
Peak Hour Analysis From 07:00 to 08:00																					
Peak Hour For Entire Intersection Begins at 07:00																					
07:00	8	94	0	0	102	0	0	0	0	0	0	1	1	0	2	8	0	5	0	13	117
07:15	9	63	0	0	72	0	0	0	0	0	0	2	1	0	3	11	0	1	0	12	87
07:30	10	39	0	0	49	0	0	0	0	0	0	3	1	0	4	8	0	4	0	12	65
07:45	8	34	0	0	42	0	0	0	0	0	0	2	1	0	3	18	2	1	0	21	66
Total Volume	35	230	0	0	265	0	0	0	0	0	0	8	4	0	12	45	2	11	0	58	335
% App Total	13.2%	86.8%	0.0%	0.0%		0.0%	0.0%	0.0%	0.0%		0.0%	66.7%	33.3%	0.0%		77.6%	3.4%	19.0%	0.0%		
PHF	.875	.612	.000	.000	.650	.000	.000	.000	.000	.000	.000	.667	1.000	.000	.750	.625	.250	.550	.000	.690	.716

PM PEAK HOUR	Corral Hollow Road Southbound					I-580 EB Ramps Westbound					Corral Hollow Road Northbound					I-580 EB Ramps Eastbound					Total
	LEFT	THRU	RIGHT	UTURNS	APP.TOTAL	LEFT	THRU	RIGHT	UTURNS	APP.TOTAL	LEFT	THRU	RIGHT	UTURNS	APP.TOTAL	LEFT	THRU	RIGHT	UTURNS	APP.TOTAL	
Peak Hour Analysis From 17:00 to 18:00																					
Peak Hour For Entire Intersection Begins at 17:00																					
17:00	17	5	0	0	22	0	0	0	0	0	0	29	57	0	86	57	0	3	0	60	168
17:15	24	4	0	0	28	0	0	0	0	0	0	49	61	0	110	66	0	0	0	66	204
17:30	26	1	0	0	27	0	0	0	0	0	0	65	57	0	122	70	1	1	0	72	221
17:45	15	2	0	0	17	0	0	0	0	0	0	42	68	0	110	64	1	0	0	65	192
Total Volume	82	12	0	0	94	0	0	0	0	0	0	185	243	0	428	257	2	4	0	263	785
% App Total	87.2%	12.8%	0.0%	0.0%		0.0%	0.0%	0.0%	0.0%		0.0%	43.2%	56.8%	0.0%		97.7%	0.8%	1.5%	0.0%		
PHF	.788	.600	.000	.000	.839	.000	.000	.000	.000	.000	.000	.712	.893	.000	.877	.918	.500	.333	.000	.913	.888

ALL TRAFFIC DATA

City of Tracy
 All Vehicles on Unshifted
 Buses on Bank 1
 FHWA Class 5 and above on Bank 2

(916) 771-8700

orders@atdtraffic.com

File Name : 13-7322-001 Corral Hollow Road-I-580 EB Ramps.ppd

Date : 5/22/2013

Bank 1 Count = Buses

START TIME	Corral Hollow Road Southbound					I-580 EB Ramps Westbound					Corral Hollow Road Northbound					I-580 EB Ramps Eastbound					Total	Ped Total
	LEFT	THRU	RIGHT	PEDS	APP.TOTAL	LEFT	THRU	RIGHT	PEDS	APP.TOTAL	LEFT	THRU	RIGHT	PEDS	APP.TOTAL	LEFT	THRU	RIGHT	PEDS	APP.TOTAL		
07:00	0	0	0	0	0	0	0	0	0	0	0	1	0	0	1	0	0	0	0	0	0	0
07:15	0	0	0	0	0	0	0	0	0	0	0	0	0	0	0	0	0	0	0	0	0	0
07:30	0	0	0	0	0	0	0	0	0	0	0	0	0	0	0	0	0	0	0	0	0	0
07:45	0	0	0	0	0	0	0	0	0	0	0	0	0	0	0	0	0	0	0	0	0	0
Total	0	0	0	0	0	0	0	0	0	0	0	1	0	0	1	0	0	0	0	0	0	0
08:00	0	0	0	0	0	0	0	0	0	0	0	0	0	0	0	0	0	0	0	0	0	0
08:15	0	0	0	0	0	0	0	0	0	0	0	0	0	0	0	0	0	0	0	0	0	0
08:30	0	0	0	0	0	0	0	0	0	0	0	0	0	0	0	0	0	0	0	0	0	0
08:45	0	0	0	0	0	0	0	0	0	0	0	0	0	0	0	0	0	0	0	0	0	0
Total	0	0	0	0	0	0	0	0	0	0	0	0	0	0	0	0	0	0	0	0	0	0
16:00	0	0	0	0	0	0	0	0	0	0	0	0	0	0	0	0	0	0	0	0	0	0
16:15	0	0	0	0	0	0	0	0	0	0	0	0	0	0	0	0	0	0	0	0	0	0
16:30	0	0	0	0	0	0	0	0	0	0	0	0	0	0	0	0	0	0	0	0	0	0
16:45	0	0	0	0	0	0	0	0	0	0	0	0	0	0	0	0	0	0	0	0	0	0
Total	0	0	0	0	0	0	0	0	0	0	0	0	0	0	0	0	0	0	0	0	0	0
17:00	0	0	0	0	0	0	0	0	0	0	0	0	0	0	0	0	0	0	0	0	0	0
17:15	0	0	0	0	0	0	0	0	0	0	0	0	0	0	0	0	0	0	0	0	0	0
17:30	0	0	0	0	0	0	0	0	0	0	0	0	0	0	0	0	0	0	0	0	0	0
17:45	0	0	0	0	0	0	0	0	0	0	0	0	0	0	0	0	0	0	0	0	0	0
Total	0	0	0	0	0	0	0	0	0	0	0	0	0	0	0	0	0	0	0	0	0	0
Grand Total	0	0	0	0	0	0	0	0	0	0	0	1	0	0	1	0	0	0	0	0	0	0
Apprch %	0.0%	0.0%	0.0%			0.0%	0.0%	0.0%			0.0%	100.0%	0.0%			0.0%	0.0%	0.0%				
Total %	0.0%	0.0%	0.0%		0.0%	0.0%	0.0%	0.0%		0.0%	0.0%	100.0%	0.0%		100.0%	0.0%	0.0%	0.0%		0.0%	100.0%	

AM PEAK HOUR	Corral Hollow Road Southbound					I-580 EB Ramps Westbound					Corral Hollow Road Northbound					I-580 EB Ramps Eastbound					Total	
	LEFT	THRU	RIGHT		APP.TOTAL	LEFT	THRU	RIGHT		APP.TOTAL	LEFT	THRU	RIGHT		APP.TOTAL	LEFT	THRU	RIGHT		APP.TOTAL		
Peak Hour Analysis From 07:00 to 08:00																						
Peak Hour For Entire Intersection Begins at 07:00																						
07:00	0	0	0		0	0	0	0		0	0	1	0		1	0	0	0		0	0	1
07:15	0	0	0		0	0	0	0		0	0	0	0		0	0	0	0		0	0	0
07:30	0	0	0		0	0	0	0		0	0	0	0		0	0	0	0		0	0	0
07:45	0	0	0		0	0	0	0		0	0	0	0		0	0	0	0		0	0	0
Total Volume	0	0	0		0	0	0	0		0	0	1	0		1	0	0	0		0	0	1
% App Total	0.0%	0.0%	0.0%			0.0%	0.0%	0.0%			0.0%	100.0%	0.0%			0.0%	0.0%	0.0%				
PHF	.000	.000	.000		.000	.000	.000	.000		.000	.000	.250	.000		.250	.000	.000	.000		.000	.000	.250

PM PEAK HOUR	Corral Hollow Road Southbound					I-580 EB Ramps Westbound					Corral Hollow Road Northbound					I-580 EB Ramps Eastbound					Total	
	LEFT	THRU	RIGHT		APP.TOTAL	LEFT	THRU	RIGHT		APP.TOTAL	LEFT	THRU	RIGHT		APP.TOTAL	LEFT	THRU	RIGHT		APP.TOTAL		
Peak Hour Analysis From 17:00 to 18:00																						
Peak Hour For Entire Intersection Begins at 17:00																						
17:00	0	0	0		0	0	0	0		0	0	0	0		0	0	0	0		0	0	0
17:15	0	0	0		0	0	0	0		0	0	0	0		0	0	0	0		0	0	0
17:30	0	0	0		0	0	0	0		0	0	0	0		0	0	0	0		0	0	0
17:45	0	0	0		0	0	0	0		0	0	0	0		0	0	0	0		0	0	0
Total Volume	0	0	0		0	0	0	0		0	0	0	0		0	0	0	0		0	0	0
% App Total	0.0%	0.0%	0.0%			0.0%	0.0%	0.0%			0.0%	0.0%	0.0%			0.0%	0.0%	0.0%				
PHF	.000	.000	.000		.000	.000	.000	.000		.000	.000	.000	.000		.000	.000	.000	.000		.000	.000	.000

ALL TRAFFIC DATA

City of Tracy
 All Vehicles on Unshifted
 Buses on Bank 1
 FHWA Class 5 and above on Bank 2

(916) 771-8700
orders@atdtraffic.com

File Name : 13-7322-001 Corral Hollow Road-I-580 EB Ramps.ppd
 Date : 5/22/2013

ank 2 Count = FHWA Class 5 and above

START TIME	Corral Hollow Road Southbound					I-580 EB Ramps Westbound					Corral Hollow Road Northbound					I-580 EB Ramps Eastbound					Total	Ped Total
	LEFT	THRU	RIGHT	PEDS	APP.TOTAL	LEFT	THRU	RIGHT	PEDS	APP.TOTAL	LEFT	THRU	RIGHT	PEDS	APP.TOTAL	LEFT	THRU	RIGHT	PEDS	APP.TOTAL		
07:00	0	0	0	0	0	0	0	0	0	0	0	0	0	0	0	1	0	1	0	2	2	0
07:15	3	0	0	0	3	0	0	0	0	0	0	1	0	0	1	3	0	1	0	4	8	0
07:30	1	0	0	0	1	0	0	0	0	0	0	0	0	0	0	2	0	0	0	2	3	0
07:45	7	0	0	0	7	0	0	0	0	0	0	0	0	0	0	3	0	0	0	3	10	0
Total	11	0	0	0	11	0	0	0	0	0	0	1	0	0	1	9	0	2	0	11	23	0
08:00	3	1	0	0	4	0	0	0	0	0	0	0	0	0	0	5	0	0	0	5	9	0
08:15	1	0	0	0	1	0	0	0	0	0	0	1	0	0	1	2	0	0	0	2	4	0
08:30	10	0	0	0	10	0	0	0	0	0	0	0	0	0	0	3	0	0	0	3	13	0
08:45	2	1	0	0	3	0	0	0	0	0	0	0	0	0	0	4	0	0	0	4	7	0
Total	16	2	0	0	18	0	0	0	0	0	0	1	0	0	1	14	0	0	0	14	33	0
16:00	7	0	0	0	7	0	0	0	0	0	0	0	1	0	1	2	0	0	0	2	10	0
16:15	3	0	0	0	3	0	0	0	0	0	0	0	1	0	1	1	0	0	0	1	5	0
16:30	1	0	0	0	1	0	0	0	0	0	0	0	0	0	0	2	0	0	0	2	3	0
16:45	2	1	0	0	3	0	0	0	0	0	0	0	0	0	0	3	0	0	0	3	6	0
Total	13	1	0	0	14	0	0	0	0	0	0	0	2	0	2	8	0	0	0	8	24	0
17:00	1	1	0	0	2	0	0	0	0	0	0	0	0	0	0	3	0	0	0	3	5	0
17:15	2	0	0	0	2	0	0	0	0	0	0	1	0	0	1	2	0	0	0	2	5	0
17:30	3	0	0	0	3	0	0	0	0	0	0	0	0	0	0	1	0	0	0	1	4	0
17:45	2	0	0	0	2	0	0	0	0	0	0	1	0	0	1	1	1	0	0	2	5	0
Total	8	1	0	0	9	0	0	0	0	0	0	2	0	0	2	7	1	0	0	8	19	0
Grand Total	48	4	0	0	52	0	0	0	0	0	0	4	2	0	6	38	1	2	0	41	99	0
Apprch %	92.3%	7.7%	0.0%			0.0%	0.0%	0.0%			0.0%	66.7%	33.3%			92.7%	2.4%	4.9%				
Total %	48.5%	4.0%	0.0%		52.5%	0.0%	0.0%	0.0%		0.0%	0.0%	4.0%	2.0%		6.1%	38.4%	1.0%	2.0%		41.4%	100.0%	

AM PEAK HOUR	Corral Hollow Road Southbound					I-580 EB Ramps Westbound					Corral Hollow Road Northbound					I-580 EB Ramps Eastbound					Total
START TIME	LEFT	THRU	RIGHT		APP.TOTAL	LEFT	THRU	RIGHT		APP.TOTAL	LEFT	THRU	RIGHT		APP.TOTAL	LEFT	THRU	RIGHT		APP.TOTAL	Total
Peak Hour Analysis From 07:00 to 08:00																					
Peak Hour For Entire Intersection Begins at 07:00																					
07:00	0	0	0		0	0	0	0		0	0	0	0		0	1	0	1		2	2
07:15	3	0	0		3	0	0	0		0	0	1	0		1	3	0	1		4	8
07:30	1	0	0		1	0	0	0		0	0	0	0		0	2	0	0		2	3
07:45	7	0	0		7	0	0	0		0	0	0	0		0	3	0	0		3	10
Total Volume	11	0	0		11	0	0	0		0	0	1	0		1	9	0	2		11	23
% App Total	100.0%	0.0%	0.0%			0.0%	0.0%	0.0%			0.0%	100.0%	0.0%			81.8%	0.0%	18.2%			
PHF	.393	.000	.000		.393	.000	.000	.000		.000	.000	.250	.000		.250	.750	.000	.500		.688	.575

PM PEAK HOUR	Corral Hollow Road Southbound					I-580 EB Ramps Westbound					Corral Hollow Road Northbound					I-580 EB Ramps Eastbound					Total
START TIME	LEFT	THRU	RIGHT		APP.TOTAL	LEFT	THRU	RIGHT		APP.TOTAL	LEFT	THRU	RIGHT		APP.TOTAL	LEFT	THRU	RIGHT		APP.TOTAL	Total
Peak Hour Analysis From 17:00 to 18:00																					
Peak Hour For Entire Intersection Begins at 17:00																					
17:00	1	1	0		2	0	0	0		0	0	0	0		0	3	0	0		3	5
17:15	2	0	0		2	0	0	0		0	0	1	0		1	2	0	0		2	5
17:30	3	0	0		3	0	0	0		0	0	0	0		0	1	0	0		1	4
17:45	2	0	0		2	0	0	0		0	0	1	0		1	1	1	0		2	5
Total Volume	8	1	0		9	0	0	0		0	0	2	0		2	7	1	0		8	19
% App Total	88.9%	11.1%	0.0%			0.0%	0.0%	0.0%			0.0%	100.0%	0.0%			87.5%	12.5%	0.0%			
PHF	.667	.250	.000		.750	.000	.000	.000		.000	.000	.500	.000		.500	.583	.250	.000		.667	.950

ALL TRAFFIC DATA

City of Tracy
 All Vehicles on Unshifted
 Buses on Bank 1
 FHWA Class 5 and above on Bank 2

(916) 771-8700
orders@atdtraffic.com

File Name : 13-7322-002 Corral Hollow Road-I-580 WB Ramps.ppd
 Date : 5/22/2013

Bank 1 Count = Buses

START TIME	Corral Hollow Road Southbound					I-580 WB Ramps Westbound					Corral Hollow Road Northbound					I-580 WB Ramps Eastbound					Total	Ped Total
	LEFT	THRU	RIGHT	PEDS	APP.TOTAL	LEFT	THRU	RIGHT	PEDS	APP.TOTAL	LEFT	THRU	RIGHT	PEDS	APP.TOTAL	LEFT	THRU	RIGHT	PEDS	APP.TOTAL		
07:00	0	0	0	0	0	0	0	0	0	0	0	1	0	0	1	0	0	0	0	0	1	0
07:15	0	0	0	0	0	0	0	0	0	0	0	0	0	0	0	0	0	0	0	0	0	0
07:30	0	0	0	0	0	0	0	0	0	0	0	0	0	0	0	0	0	0	0	0	0	0
07:45	0	0	0	0	0	0	0	0	0	0	0	0	0	0	0	0	0	0	0	0	0	0
Total	0	0	0	0	0	0	0	0	0	0	0	1	0	0	1	0	0	0	0	0	1	0
08:00	0	0	0	0	0	0	0	0	0	0	0	0	0	0	0	0	0	0	0	0	0	0
08:15	0	0	0	0	0	0	0	0	0	0	0	0	0	0	0	0	0	0	0	0	0	0
08:30	0	0	0	0	0	0	0	0	0	0	0	0	0	0	0	0	0	0	0	0	0	0
08:45	0	0	0	0	0	0	0	0	0	0	0	0	0	0	0	0	0	0	0	0	0	0
Total	0	0	0	0	0	0	0	0	0	0	0	0	0	0	0	0	0	0	0	0	0	0
16:00	0	0	0	0	0	0	0	0	0	0	0	0	0	0	0	0	0	0	0	0	0	0
16:15	0	0	0	0	0	0	0	0	0	0	0	0	0	0	0	0	0	0	0	0	0	0
16:30	0	0	0	0	0	0	0	0	0	0	0	0	0	0	0	0	0	0	0	0	0	0
16:45	0	0	0	0	0	0	0	0	0	0	0	0	0	0	0	0	0	0	0	0	0	0
Total	0	0	0	0	0	0	0	0	0	0	0	0	0	0	0	0	0	0	0	0	0	0
17:00	0	0	0	0	0	0	0	0	0	0	0	0	0	0	0	0	0	0	0	0	0	0
17:15	0	0	0	0	0	0	0	0	0	0	0	0	0	0	0	0	0	0	0	0	0	0
17:30	0	0	0	0	0	0	0	0	0	0	0	0	0	0	0	0	0	0	0	0	0	0
17:45	0	0	0	0	0	0	0	0	0	0	0	0	0	0	0	0	0	0	0	0	0	0
Total	0	0	0	0	0	0	0	0	0	0	0	0	0	0	0	0	0	0	0	0	0	0
Grand Total	0	0	0	0	0	0	0	0	0	0	0	1	0	0	1	0	0	0	0	0	1	0
Apprch %	0.0%	0.0%	0.0%			0.0%	0.0%	0.0%			0.0%	100.0%	0.0%			0.0%	0.0%	0.0%				
Total %	0.0%	0.0%	0.0%		0.0%	0.0%	0.0%	0.0%		0.0%	0.0%	100.0%	0.0%		100.0%	0.0%	0.0%	0.0%		0.0%	100.0%	

AM PEAK HOUR	Corral Hollow Road Southbound					I-580 WB Ramps Westbound					Corral Hollow Road Northbound					I-580 WB Ramps Eastbound					Total
	LEFT	THRU	RIGHT		APP.TOTAL	LEFT	THRU	RIGHT		APP.TOTAL	LEFT	THRU	RIGHT		APP.TOTAL	LEFT	THRU	RIGHT		APP.TOTAL	
Peak Hour Analysis From 07:00 to 08:00																					
Peak Hour For Entire Intersection Begins at 07:00																					
07:00	0	0	0		0	0	0	0		0	0	1	0		1	0	0	0		0	1
07:15	0	0	0		0	0	0	0		0	0	0	0		0	0	0	0		0	0
07:30	0	0	0		0	0	0	0		0	0	0	0		0	0	0	0		0	0
07:45	0	0	0		0	0	0	0		0	0	0	0		0	0	0	0		0	0
Total Volume	0	0	0		0	0	0	0		0	1	0		1	0	0	0		0	1	
% App Total	0.0%	0.0%	0.0%			0.0%	0.0%	0.0%			0.0%	100.0%	0.0%			0.0%	0.0%	0.0%			
PHF	.000	.000	.000		.000	.000	.000	.000		.000	.250	.000		.250	.000	.000	.000		.000	.250	

PM PEAK HOUR	Corral Hollow Road Southbound					I-580 WB Ramps Westbound					Corral Hollow Road Northbound					I-580 WB Ramps Eastbound					Total
	LEFT	THRU	RIGHT		APP.TOTAL	LEFT	THRU	RIGHT		APP.TOTAL	LEFT	THRU	RIGHT		APP.TOTAL	LEFT	THRU	RIGHT		APP.TOTAL	
Peak Hour Analysis From 17:00 to 18:00																					
Peak Hour For Entire Intersection Begins at 17:00																					
17:00	0	0	0		0	0	0	0		0	0	0	0		0	0	0	0		0	0
17:15	0	0	0		0	0	0	0		0	0	0	0		0	0	0	0		0	0
17:30	0	0	0		0	0	0	0		0	0	0	0		0	0	0	0		0	0
17:45	0	0	0		0	0	0	0		0	0	0	0		0	0	0	0		0	0
Total Volume	0	0	0		0	0	0	0		0	0	0	0		0	0	0	0		0	0
% App Total	0.0%	0.0%	0.0%			0.0%	0.0%	0.0%			0.0%	0.0%	0.0%			0.0%	0.0%	0.0%			
PHF	.000	.000	.000		.000	.000	.000	.000		.000	.000	.000		.000	.000	.000	.000		.000	.000	

ALL TRAFFIC DATA

City of Tracy
 All Vehicles on Unshifted
 Buses on Bank 1
 FHWA Class 5 and above on Bank 2

(916) 771-8700
orders@atdtraffic.com

File Name : 13-7322-002 Corral Hollow Road-I-580 WB Ramps.ppd
 Date : 5/22/2013

ank 2 Count = FHWA Class 5 and above

START TIME	Corral Hollow Road Southbound					I-580 WB Ramps Westbound					Corral Hollow Road Northbound					I-580 WB Ramps Eastbound					Total	Ped Total
	LEFT	THRU	RIGHT	PEDS	APP.TOTAL	LEFT	THRU	RIGHT	PEDS	APP.TOTAL	LEFT	THRU	RIGHT	PEDS	APP.TOTAL	LEFT	THRU	RIGHT	PEDS	APP.TOTAL		
07:00	0	0	2	0	2	0	0	10	0	10	0	1	0	0	1	0	0	0	0	0	13	0
07:15	0	4	1	0	5	0	0	4	0	4	1	3	0	0	4	0	0	0	0	0	13	0
07:30	0	0	0	0	0	0	0	4	0	4	0	2	0	0	2	0	0	0	0	0	6	0
07:45	0	6	3	0	9	1	0	8	0	9	0	3	0	0	3	0	0	0	0	0	21	0
Total	0	10	6	0	16	1	0	26	0	27	1	9	0	0	10	0	0	0	0	0	53	0
08:00	0	4	3	0	7	0	0	5	0	5	0	4	0	0	4	0	0	0	0	0	16	0
08:15	0	1	4	0	5	1	0	7	0	8	1	3	0	0	4	0	0	0	0	0	17	0
08:30	0	9	5	0	14	0	0	4	0	4	0	2	0	0	2	0	0	0	0	0	20	0
08:45	0	3	3	0	6	0	0	4	0	4	0	5	0	0	5	0	0	0	0	0	15	0
Total	0	17	15	0	32	1	0	20	0	21	1	14	0	0	15	0	0	0	0	0	68	0
16:00	0	7	0	0	7	0	0	2	0	2	0	3	0	0	3	0	0	0	0	0	12	0
16:15	0	3	0	0	3	0	0	5	0	5	0	1	0	0	1	0	0	0	0	0	9	0
16:30	0	3	1	0	4	0	0	2	0	2	0	1	0	0	1	0	0	0	0	0	7	0
16:45	0	3	1	0	4	0	0	2	0	2	0	4	0	0	4	0	0	0	0	0	10	0
Total	0	16	2	0	18	0	0	11	0	11	0	9	0	0	9	0	0	0	0	0	38	0
17:00	0	1	0	0	1	0	0	1	0	1	0	3	0	0	3	0	0	0	0	0	5	0
17:15	0	2	1	0	3	0	0	0	0	0	1	1	0	0	2	0	0	0	0	0	5	0
17:30	0	3	1	0	4	0	0	1	0	1	0	2	0	0	2	0	0	0	0	0	7	0
17:45	0	2	1	0	3	0	0	0	0	0	0	0	0	0	0	0	0	0	0	0	3	0
Total	0	8	3	0	11	0	0	2	0	2	1	6	0	0	7	0	0	0	0	0	20	0
Grand Total	0	51	26	0	77	2	0	59	0	61	3	38	0	0	41	0	0	0	0	0	179	0
Approch %	0.0%	66.2%	33.8%			3.3%	0.0%	96.7%			7.3%	92.7%	0.0%			0.0%	0.0%	0.0%				
Total %	0.0%	28.5%	14.5%		43.0%	1.1%	0.0%	33.0%		34.1%	1.7%	21.2%	0.0%		22.9%	0.0%	0.0%	0.0%		0.0%	100.0%	

AM PEAK HOUR	Corral Hollow Road Southbound					I-580 WB Ramps Westbound					Corral Hollow Road Northbound					I-580 WB Ramps Eastbound					Total
START TIME	LEFT	THRU	RIGHT		APP.TOTAL	LEFT	THRU	RIGHT		APP.TOTAL	LEFT	THRU	RIGHT		APP.TOTAL	LEFT	THRU	RIGHT		APP.TOTAL	Total
Peak Hour Analysis From 07:00 to 08:00																					
Peak Hour For Entire Intersection Begins at 07:00																					
07:00	0	0	2		2	0	0	10		10	0	1	0		1	0	0	0		0	13
07:15	0	4	1		5	0	0	4		4	1	3	0		4	0	0	0		0	13
07:30	0	0	0		0	0	0	4		4	0	2	0		2	0	0	0		0	6
07:45	0	6	3		9	1	0	8		9	0	3	0		3	0	0	0		0	21
Total Volume	0	10	6		16	1	0	26		27	1	9	0		10	0	0	0		0	53
% App Total	0.0%	62.5%	37.5%			3.7%	0.0%	96.3%			10.0%	90.0%	0.0%			0.0%	0.0%	0.0%			
PHF	.000	.417	.500		.444	.250	.000	.650		.675	.250	.750	.000		.625	.000	.000	.000		.000	.631

PM PEAK HOUR	Corral Hollow Road Southbound					I-580 WB Ramps Westbound					Corral Hollow Road Northbound					I-580 WB Ramps Eastbound					Total
START TIME	LEFT	THRU	RIGHT		APP.TOTAL	LEFT	THRU	RIGHT		APP.TOTAL	LEFT	THRU	RIGHT		APP.TOTAL	LEFT	THRU	RIGHT		APP.TOTAL	Total
Peak Hour Analysis From 17:00 to 18:00																					
Peak Hour For Entire Intersection Begins at 17:00																					
17:00	0	1	0		1	0	0	1		1	0	3	0		3	0	0	0		0	5
17:15	0	2	1		3	0	0	0		0	1	1	0		2	0	0	0		0	5
17:30	0	3	1		4	0	0	1		1	0	2	0		2	0	0	0		0	7
17:45	0	2	1		3	0	0	0		0	0	0	0		0	0	0	0		0	3
Total Volume	0	8	3		11	0	0	2		2	1	6	0		7	0	0	0		0	20
% App Total	0.0%	72.7%	27.3%			0.0%	0.0%	100.0%			14.3%	85.7%	0.0%			0.0%	0.0%	0.0%			
PHF	.000	.667	.750		.688	.000	.000	.500		.500	.250	.500	.000		.583	.000	.000	.000		.000	.714

ALL TRAFFIC DATA

City of Tracy
 All Vehicles on Unshifted
 Nothing on Bank 1
 Nothing on Bank 2

(916) 771-8700

orders@atdtraffic.com

File Name : 13-7322-004 Corral Hollow Road-Linne Road.ppd

Date : 5/22/2013

Unshifted Count = All Vehicles

START TIME	Corral Hollow Road Southbound					Linne Road Westbound					Corral Hollow Road Northbound					Dirt Driveway Eastbound					Total	Utum Total
	LEFT	THRU	RIGHT	UTURNS	APP.TOTAL	LEFT	THRU	RIGHT	UTURNS	APP.TOTAL	LEFT	THRU	RIGHT	UTURNS	APP.TOTAL	LEFT	THRU	RIGHT	UTURNS	APP.TOTAL		
07:00	14	72	0	0	86	69	0	17	0	86	0	18	6	0	24	0	0	0	0	0	196	0
07:15	3	60	0	0	63	53	0	5	0	58	0	13	15	0	28	0	0	0	0	0	149	0
07:30	16	61	0	0	77	43	0	14	0	57	0	17	10	0	27	0	0	0	0	0	161	0
07:45	13	47	0	0	60	55	0	15	0	70	0	18	29	0	47	0	0	0	0	0	177	0
Total	46	240	0	0	286	220	0	51	0	271	0	66	60	0	126	0	0	0	0	0	683	0
08:00	12	56	0	0	68	43	0	15	0	58	0	19	7	0	26	0	0	0	0	0	152	0
08:15	14	66	0	0	80	55	0	15	0	70	0	23	18	0	41	0	0	0	0	0	191	0
08:30	12	49	0	0	61	36	0	12	0	48	0	10	10	0	20	0	0	1	0	1	130	0
08:45	8	42	0	0	50	29	0	23	0	52	0	11	10	0	21	0	0	0	0	0	123	0
Total	46	213	0	0	259	163	0	65	0	228	0	63	45	0	108	0	0	1	0	1	596	0
16:00	15	27	0	0	42	20	0	16	0	36	0	48	32	0	80	0	0	0	0	0	158	0
16:15	9	20	0	0	29	13	0	10	0	23	0	49	54	0	103	0	0	0	0	0	155	0
16:30	9	24	0	0	33	18	0	12	0	30	0	49	42	0	91	0	0	0	0	0	154	0
16:45	11	17	0	0	28	16	0	10	0	26	0	60	49	0	109	0	0	0	0	0	163	0
Total	44	88	0	0	132	67	0	48	0	115	0	206	177	0	383	0	0	0	0	0	630	0
17:00	8	28	0	0	36	16	0	21	0	37	0	51	41	0	92	0	0	0	0	0	165	0
17:15	13	24	0	0	37	16	0	14	0	30	0	63	58	0	121	0	1	0	0	1	189	0
17:30	14	30	0	0	44	16	0	13	0	29	0	61	54	0	115	0	0	0	0	0	188	0
17:45	17	20	0	0	37	13	0	5	0	18	0	73	59	0	132	0	0	0	0	0	187	0
Total	52	102	0	0	154	61	0	53	0	114	0	248	212	0	460	0	1	0	0	1	729	0
Grand Total	188	643	0	0	831	511	0	217	0	728	0	583	494	0	1077	0	1	1	0	2	2638	0
Apprch %	22.6%	77.4%	0.0%	0.0%		70.2%	0.0%	29.8%	0.0%		0.0%	54.1%	45.9%	0.0%		0.0%	50.0%	50.0%	0.0%			
Total %	7.1%	24.4%	0.0%	0.0%	31.5%	19.4%	0.0%	8.2%	0.0%	27.6%	0.0%	22.1%	18.7%	0.0%	40.8%	0.0%	0.0%	0.0%	0.0%	0.1%	100.0%	

AM PEAK HOUR	Corral Hollow Road Southbound					Linne Road Westbound					Corral Hollow Road Northbound					Dirt Driveway Eastbound					Total
START TIME	LEFT	THRU	RIGHT	UTURNS	APP.TOTAL	LEFT	THRU	RIGHT	UTURNS	APP.TOTAL	LEFT	THRU	RIGHT	UTURNS	APP.TOTAL	LEFT	THRU	RIGHT	UTURNS	APP.TOTAL	
Peak Hour Analysis From 07:00 to 08:00																					
Peak Hour For Entire Intersection Begins at 07:00																					
07:00	14	72	0	0	86	69	0	17	0	86	0	18	6	0	24	0	0	0	0	0	196
07:15	3	60	0	0	63	53	0	5	0	58	0	13	15	0	28	0	0	0	0	0	149
07:30	16	61	0	0	77	43	0	14	0	57	0	17	10	0	27	0	0	0	0	0	161
07:45	13	47	0	0	60	55	0	15	0	70	0	18	29	0	47	0	0	0	0	0	177
Total Volume	46	240	0	0	286	220	0	51	0	271	0	66	60	0	126	0	0	0	0	0	683
% App Total	16.1%	83.9%	0.0%	0.0%		81.2%	0.0%	18.8%	0.0%		0.0%	52.4%	47.6%	0.0%		0.0%	0.0%	0.0%	0.0%		
PHF	.719	.833	.000	.000	.831	.797	.000	.750	.000	.788	.000	.917	.517	.000	.670	.000	.000	.000	.000	.000	.871

PM PEAK HOUR	Corral Hollow Road Southbound					Linne Road Westbound					Corral Hollow Road Northbound					Dirt Driveway Eastbound					Total
START TIME	LEFT	THRU	RIGHT	UTURNS	APP.TOTAL	LEFT	THRU	RIGHT	UTURNS	APP.TOTAL	LEFT	THRU	RIGHT	UTURNS	APP.TOTAL	LEFT	THRU	RIGHT	UTURNS	APP.TOTAL	
Peak Hour Analysis From 17:00 to 18:00																					
Peak Hour For Entire Intersection Begins at 17:00																					
17:00	8	28	0	0	36	16	0	21	0	37	0	51	41	0	92	0	0	0	0	0	165
17:15	13	24	0	0	37	16	0	14	0	30	0	63	58	0	121	0	1	0	0	1	189
17:30	14	30	0	0	44	16	0	13	0	29	0	61	54	0	115	0	0	0	0	0	188
17:45	17	20	0	0	37	13	0	5	0	18	0	73	59	0	132	0	0	0	0	0	187
Total Volume	52	102	0	0	154	61	0	53	0	114	0	248	212	0	460	0	1	0	0	1	729
% App Total	33.8%	66.2%	0.0%	0.0%		53.5%	0.0%	46.5%	0.0%		0.0%	53.9%	46.1%	0.0%		0.0%	100.0%	0.0%	0.0%		
PHF	.765	.850	.000	.000	.875	.953	.000	.631	.000	.770	.000	.849	.898	.000	.871	.000	.250	.000	.000	.250	.964

ALL TRAFFIC DATA

City of Tracy
 All Vehicles on Unshifted
 Nothing on Bank 1
 Nothing on Bank 2

(916) 771-8700

orders@atdtraffic.com

File Name : 13-7322-005 Tracy Boulevard-Linne Road.ppd

Date : 5/22/2013

Unshifted Count = All Vehicles

START TIME	Tracy Boulevard Southbound					Linne Road Westbound					Tracy Boulevard Northbound					Linne Road Eastbound					Total	Utum Total
	LEFT	THRU	RIGHT	UTURNS	APP.TOTAL	LEFT	THRU	RIGHT	UTURNS	APP.TOTAL	LEFT	THRU	RIGHT	UTURNS	APP.TOTAL	LEFT	THRU	RIGHT	UTURNS	APP.TOTAL		
07:00	12	3	43	0	58	0	30	18	0	48	4	2	5	0	11	8	10	4	0	22	139	0
07:15	15	3	29	0	47	2	28	18	0	48	1	8	2	0	11	8	4	2	0	14	120	0
07:30	31	5	23	0	59	6	35	35	0	76	4	3	2	0	9	5	16	3	0	24	168	0
07:45	57	6	41	0	104	3	29	54	0	86	3	7	5	0	15	11	11	4	0	26	231	0
Total	115	17	136	0	288	11	122	125	0	258	12	20	14	0	46	32	41	13	0	86	658	0
08:00	31	8	27	0	66	9	35	55	0	99	2	1	4	0	7	6	18	2	0	26	198	0
08:15	23	7	30	0	60	3	29	21	0	53	5	1	5	0	11	6	16	1	0	23	147	0
08:30	5	3	23	0	31	5	21	11	0	37	7	4	3	0	14	7	16	3	0	26	108	0
08:45	11	7	15	0	33	3	29	9	0	41	2	3	4	0	9	1	9	3	0	13	96	0
Total	70	25	95	0	190	20	114	96	0	230	16	9	16	0	41	20	59	9	0	88	549	0
16:00	18	7	15	0	40	4	12	17	0	33	2	8	7	0	17	23	23	4	0	50	140	0
16:15	13	10	7	0	30	2	10	15	0	27	6	13	5	0	24	29	37	1	0	67	148	0
16:30	18	7	9	0	34	1	15	13	0	29	1	9	8	0	18	27	20	3	0	50	131	0
16:45	14	3	9	0	26	3	12	12	0	27	2	6	1	0	9	32	19	7	0	58	120	0
Total	63	27	40	0	130	10	49	57	0	116	11	36	21	0	68	111	99	15	0	225	539	0
17:00	21	8	16	0	45	1	14	15	0	30	4	6	1	0	11	24	35	5	0	64	150	0
17:15	25	5	10	0	40	1	12	11	0	24	1	7	3	0	11	42	32	2	0	76	151	0
17:30	18	3	12	0	33	1	19	22	0	42	3	6	6	0	15	31	33	6	0	70	160	0
17:45	29	5	10	0	44	0	7	23	0	30	4	11	6	0	21	39	33	5	0	77	172	0
Total	93	21	48	0	162	3	52	71	0	126	12	30	16	0	58	136	133	18	0	287	633	0
Grand Total	341	90	319	0	750	44	337	349	0	730	51	95	67	0	213	299	332	55	0	686	2379	0
Approch %	45.5%	12.0%	42.5%	0.0%		6.0%	46.2%	47.8%	0.0%		23.9%	44.6%	31.5%	0.0%		43.6%	48.4%	8.0%	0.0%			
Total %	14.3%	3.8%	13.4%	0.0%	31.5%	1.8%	14.2%	14.7%	0.0%	30.7%	2.1%	4.0%	2.8%	0.0%	9.0%	12.6%	14.0%	2.3%	0.0%	28.8%	100.0%	

AM PEAK HOUR	Tracy Boulevard Southbound					Linne Road Westbound					Tracy Boulevard Northbound					Linne Road Eastbound					Total
	LEFT	THRU	RIGHT	UTURNS	APP.TOTAL	LEFT	THRU	RIGHT	UTURNS	APP.TOTAL	LEFT	THRU	RIGHT	UTURNS	APP.TOTAL	LEFT	THRU	RIGHT	UTURNS	APP.TOTAL	
Peak Hour Analysis From 07:30 to 08:30																					
Peak Hour For Entire Intersection Begins at 07:30																					
07:30	31	5	23	0	59	6	35	35	0	76	4	3	2	0	9	5	16	3	0	24	168
07:45	57	6	41	0	104	3	29	54	0	86	3	7	5	0	15	11	11	4	0	26	231
08:00	31	8	27	0	66	9	35	55	0	99	2	1	4	0	7	6	18	2	0	26	198
08:15	23	7	30	0	60	3	29	21	0	53	5	1	5	0	11	6	16	1	0	23	147
Total Volume	142	26	121	0	289	21	128	165	0	314	14	12	16	0	42	28	61	10	0	99	744
% App Total	49.1%	9.0%	41.9%	0.0%		6.7%	40.8%	52.5%	0.0%		33.3%	28.6%	38.1%	0.0%		28.3%	61.6%	10.1%	0.0%		
PHF	.623	.813	.738	.000	.695	.583	.914	.750	.000	.793	.700	.429	.800	.000	.700	.636	.847	.625	.000	.952	.805

PM PEAK HOUR	Tracy Boulevard Southbound					Linne Road Westbound					Tracy Boulevard Northbound					Linne Road Eastbound					Total
	LEFT	THRU	RIGHT	UTURNS	APP.TOTAL	LEFT	THRU	RIGHT	UTURNS	APP.TOTAL	LEFT	THRU	RIGHT	UTURNS	APP.TOTAL	LEFT	THRU	RIGHT	UTURNS	APP.TOTAL	
Peak Hour Analysis From 17:00 to 18:00																					
Peak Hour For Entire Intersection Begins at 17:00																					
17:00	21	8	16	0	45	1	14	15	0	30	4	6	1	0	11	24	35	5	0	64	150
17:15	25	5	10	0	40	1	12	11	0	24	1	7	3	0	11	42	32	2	0	76	151
17:30	18	3	12	0	33	1	19	22	0	42	3	6	6	0	15	31	33	6	0	70	160
17:45	29	5	10	0	44	0	7	23	0	30	4	11	6	0	21	39	33	5	0	77	172
Total Volume	93	21	48	0	162	3	52	71	0	126	12	30	16	0	58	136	133	18	0	287	633
% App Total	57.4%	13.0%	29.6%	0.0%		2.4%	41.3%	56.3%	0.0%		20.7%	51.7%	27.6%	0.0%		47.4%	46.3%	6.3%	0.0%		
PHF	.802	.656	.750	.000	.900	.750	.684	.772	.000	.750	.750	.682	.667	.000	.690	.810	.950	.750	.000	.932	.920

ALL TRAFFIC DATA

City of Tracy
 All Vehicles on Unshifted
 Nothing on Bank 1
 Nothing on Bank 2

(916) 771-8700

orders@atdtraffic.com

File Name : 13-7322-006 Tracy Boulevard-Valpico .ppd

Date : 5/22/2013

Unshifted Count = All Vehicles

START TIME	Tracy Boulevard Southbound					Valpico Westbound					Tracy Boulevard Northbound					Valpico Eastbound					Total	Utum Total
	LEFT	THRU	RIGHT	UTURNS	APP.TOTAL	LEFT	THRU	RIGHT	UTURNS	APP.TOTAL	LEFT	THRU	RIGHT	UTURNS	APP.TOTAL	LEFT	THRU	RIGHT	UTURNS	APP.TOTAL		
07:00	16	50	12	0	78	20	55	19	1	95	20	60	17	8	105	15	37	16	0	68	346	9
07:15	20	53	14	0	87	33	54	21	0	108	15	72	34	5	126	24	42	13	0	79	400	5
07:30	37	47	12	0	96	28	50	60	3	141	23	117	25	6	171	38	46	11	0	95	503	9
07:45	44	69	28	0	141	60	74	62	0	196	19	94	23	5	141	29	68	16	0	113	591	5
Total	117	219	66	0	402	141	233	162	4	540	77	343	99	24	543	106	193	56	0	355	1840	28
08:00	49	80	25	0	154	37	68	49	0	154	16	84	22	9	131	33	57	12	0	102	541	9
08:15	45	45	15	0	105	43	45	51	0	139	15	62	30	5	112	29	50	9	0	88	444	5
08:30	48	40	7	0	95	27	38	35	1	101	21	59	14	4	98	16	40	7	0	63	357	5
08:45	31	52	12	0	95	26	30	27	0	83	18	67	19	5	109	15	25	8	0	48	335	5
Total	173	217	59	0	449	133	181	162	1	477	70	272	85	23	450	93	172	36	0	301	1677	24
16:00	49	91	22	0	162	52	41	58	3	154	23	98	31	5	157	26	64	18	0	108	581	8
16:15	48	85	18	0	151	39	52	55	2	148	21	94	24	2	141	23	71	25	0	119	559	4
16:30	51	66	14	0	131	40	47	39	3	129	27	117	31	5	180	22	78	19	0	119	559	8
16:45	52	88	18	0	158	42	62	39	1	144	23	103	38	7	171	24	68	30	0	122	595	8
Total	200	330	72	0	602	173	202	191	9	575	94	412	124	19	649	95	281	92	0	468	2294	28
17:00	50	84	13	0	147	38	67	39	3	147	25	117	39	12	193	27	75	20	0	122	609	15
17:15	34	100	19	0	153	49	68	34	0	151	24	149	44	9	226	22	81	16	0	119	649	9
17:30	48	86	15	0	149	39	54	42	1	136	22	96	34	5	157	26	68	19	0	113	555	6
17:45	60	88	24	0	172	37	52	47	2	138	21	112	29	10	172	28	98	17	0	143	625	12
Total	192	358	71	0	621	163	241	162	6	572	92	474	146	36	748	103	322	72	0	497	2438	42
Grand Total	682	1124	268	0	2074	610	857	677	20	2164	333	1501	454	102	2390	397	968	256	0	1621	8249	122
Approch %	32.9%	54.2%	12.9%	0.0%		28.2%	39.6%	31.3%	0.9%		13.9%	62.8%	19.0%	4.3%		24.5%	59.7%	15.8%	0.0%			
Total %	8.3%	13.6%	3.2%	0.0%	25.1%	7.4%	10.4%	8.2%	0.2%	26.2%	4.0%	18.2%	5.5%	1.2%	29.0%	4.8%	11.7%	3.1%	0.0%	19.7%	100.0%	

AM PEAK HOUR	Tracy Boulevard Southbound					Valpico Westbound					Tracy Boulevard Northbound					Valpico Eastbound					Total
	LEFT	THRU	RIGHT	UTURNS	APP.TOTAL	LEFT	THRU	RIGHT	UTURNS	APP.TOTAL	LEFT	THRU	RIGHT	UTURNS	APP.TOTAL	LEFT	THRU	RIGHT	UTURNS	APP.TOTAL	
Peak Hour Analysis From 07:30 to 08:30																					
Peak Hour For Entire Intersection Begins at 07:30																					
07:30	37	47	12	0	96	28	50	60	3	141	23	117	25	6	171	38	46	11	0	95	503
07:45	44	69	28	0	141	60	74	62	0	196	19	94	23	5	141	29	68	16	0	113	591
08:00	49	80	25	0	154	37	68	49	0	154	16	84	22	9	131	33	57	12	0	102	541
08:15	45	45	15	0	105	43	45	51	0	139	15	62	30	5	112	29	50	9	0	88	444
Total Volume	175	241	80	0	496	168	237	222	3	630	73	357	100	25	555	129	221	48	0	398	2079
% App Total	35.3%	48.6%	16.1%	0.0%		26.7%	37.6%	35.2%	0.5%		13.2%	64.3%	18.0%	4.5%		32.4%	55.5%	12.1%	0.0%		
PHF	.893	.753	.714	.000	.805	.700	.801	.895	.250	.804	.793	.763	.833	.694	.811	.849	.813	.750	.000	.881	.879

PM PEAK HOUR	Tracy Boulevard Southbound					Valpico Westbound					Tracy Boulevard Northbound					Valpico Eastbound					Total
	LEFT	THRU	RIGHT	UTURNS	APP.TOTAL	LEFT	THRU	RIGHT	UTURNS	APP.TOTAL	LEFT	THRU	RIGHT	UTURNS	APP.TOTAL	LEFT	THRU	RIGHT	UTURNS	APP.TOTAL	
Peak Hour Analysis From 17:00 to 18:00																					
Peak Hour For Entire Intersection Begins at 17:00																					
17:00	50	84	13	0	147	38	67	39	3	147	25	117	39	12	193	27	75	20	0	122	609
17:15	34	100	19	0	153	49	68	34	0	151	24	149	44	9	226	22	81	16	0	119	649
17:30	48	86	15	0	149	39	54	42	1	136	22	96	34	5	157	26	68	19	0	113	555
17:45	60	88	24	0	172	37	52	47	2	138	21	112	29	10	172	28	98	17	0	143	625
Total Volume	192	358	71	0	621	163	241	162	6	572	92	474	146	36	748	103	322	72	0	497	2438
% App Total	30.9%	57.6%	11.4%	0.0%		28.5%	42.1%	28.3%	1.0%		12.3%	63.4%	19.5%	4.8%		20.7%	64.8%	14.5%	0.0%		
PHF	.800	.895	.740	.000	.903	.832	.886	.862	.500	.947	.920	.795	.830	.750	.827	.920	.821	.900	.000	.869	.939

ALL TRAFFIC DATA

City of Tracy
 All Vehicles on Unshifted
 Nothing on Bank 1
 Nothing on Bank 2

(916) 771-8700

orders@atdtraffic.com

File Name : 13-7322-007.ppd

Date : 5/22/2013

Unshifted Count = All Vehicles

START TIME	Corral Hollow Road Southbound					Valpico Road Westbound					Corral Hollow Road Northbound					Valpico Road Eastbound					Total	Utum Total
	LEFT	THRU	RIGHT	UTURNS	APP.TOTAL	LEFT	THRU	RIGHT	UTURNS	APP.TOTAL	LEFT	THRU	RIGHT	UTURNS	APP.TOTAL	LEFT	THRU	RIGHT	UTURNS	APP.TOTAL		
07:00	17	39	4	0	60	26	61	15	0	102	8	18	4	0	30	1	17	10	0	28	220	0
07:15	22	34	7	0	63	23	64	20	0	107	19	25	6	0	50	0	15	4	0	19	239	0
07:30	20	26	8	0	54	21	77	21	0	119	32	47	6	0	85	0	15	12	0	27	285	0
07:45	16	31	18	0	65	16	73	33	0	122	57	49	4	0	110	2	21	18	0	41	338	0
Total	75	130	37	0	242	86	275	89	0	450	116	139	20	0	275	3	68	44	0	115	1082	0
08:00	22	40	10	0	72	12	45	39	0	96	54	55	3	0	112	9	25	25	0	59	339	0
08:15	23	34	6	0	63	15	33	37	0	85	14	34	7	0	55	11	22	19	0	52	255	0
08:30	25	29	3	0	57	15	36	24	0	75	7	28	3	0	38	2	28	20	0	50	220	0
08:45	19	25	3	0	47	12	38	25	0	75	3	41	6	0	50	0	9	3	0	12	184	0
Total	89	128	22	0	239	54	152	125	0	331	78	158	19	0	255	22	84	67	0	173	998	0
16:00	29	40	0	0	69	5	21	28	0	54	6	59	12	0	77	3	54	15	0	72	272	0
16:15	39	38	3	0	80	8	17	32	0	57	7	47	6	0	60	1	51	27	0	79	276	0
16:30	42	42	1	0	85	4	30	31	0	65	8	38	14	0	60	1	57	11	0	69	279	0
16:45	39	49	2	0	90	4	35	29	0	68	15	58	12	0	85	5	68	14	0	87	330	0
Total	149	169	6	0	324	21	103	120	0	244	36	202	44	0	282	10	230	67	0	307	1157	0
17:00	36	40	2	0	78	7	26	35	0	68	6	50	12	0	68	0	72	15	0	87	301	0
17:15	38	65	2	0	105	15	31	38	0	84	10	52	18	0	80	0	51	18	0	69	338	0
17:30	41	44	2	0	87	6	23	28	0	57	10	57	19	0	86	1	58	12	0	71	301	0
17:45	54	47	1	0	102	12	15	32	0	59	4	53	18	0	75	4	73	16	0	93	329	0
Total	169	196	7	0	372	40	95	133	0	268	30	212	67	0	309	5	254	61	0	320	1269	0
Grand Total	482	623	72	0	1177	201	625	467	0	1293	260	711	150	0	1121	40	636	239	0	915	4506	0
Approch %	41.0%	52.9%	6.1%	0.0%		15.5%	48.3%	36.1%	0.0%		23.2%	63.4%	13.4%	0.0%		4.4%	69.5%	26.1%	0.0%			
Total %	10.7%	13.8%	1.6%	0.0%	26.1%	4.5%	13.9%	10.4%	0.0%	28.7%	5.8%	15.8%	3.3%	0.0%	24.9%	0.9%	14.1%	5.3%	0.0%	20.3%	100.0%	

AM PEAK HOUR	Corral Hollow Road Southbound					Valpico Road Westbound					Corral Hollow Road Northbound					Valpico Road Eastbound					Total
	LEFT	THRU	RIGHT	UTURNS	APP.TOTAL	LEFT	THRU	RIGHT	UTURNS	APP.TOTAL	LEFT	THRU	RIGHT	UTURNS	APP.TOTAL	LEFT	THRU	RIGHT	UTURNS	APP.TOTAL	
Peak Hour Analysis From 07:30 to 08:30																					
Peak Hour For Entire Intersection Begins at 07:30																					
07:30	20	26	8	0	54	21	77	21	0	119	32	47	6	0	85	0	15	12	0	27	285
07:45	16	31	18	0	65	16	73	33	0	122	57	49	4	0	110	2	21	18	0	41	338
08:00	22	40	10	0	72	12	45	39	0	96	54	55	3	0	112	9	25	25	0	59	339
08:15	23	34	6	0	63	15	33	37	0	85	14	34	7	0	55	11	22	19	0	52	255
Total Volume	81	131	42	0	254	64	228	130	0	422	157	185	20	0	362	22	83	74	0	179	1217
% App Total	31.9%	51.6%	16.5%	0.0%		15.2%	54.0%	30.8%	0.0%		43.4%	51.1%	5.5%	0.0%		12.3%	46.4%	41.3%	0.0%		
PHF	.880	.819	.583	.000	.882	.762	.740	.833	.000	.865	.689	.841	.714	.000	.808	.500	.830	.740	.000	.758	.897

PM PEAK HOUR	Corral Hollow Road Southbound					Valpico Road Westbound					Corral Hollow Road Northbound					Valpico Road Eastbound					Total
	LEFT	THRU	RIGHT	UTURNS	APP.TOTAL	LEFT	THRU	RIGHT	UTURNS	APP.TOTAL	LEFT	THRU	RIGHT	UTURNS	APP.TOTAL	LEFT	THRU	RIGHT	UTURNS	APP.TOTAL	
Peak Hour Analysis From 17:00 to 18:00																					
Peak Hour For Entire Intersection Begins at 17:00																					
17:00	36	40	2	0	78	7	26	35	0	68	6	50	12	0	68	0	72	15	0	87	301
17:15	38	65	2	0	105	15	31	38	0	84	10	52	18	0	80	0	51	18	0	69	338
17:30	41	44	2	0	87	6	23	28	0	57	10	57	19	0	86	1	58	12	0	71	301
17:45	54	47	1	0	102	12	15	32	0	59	4	53	18	0	75	4	73	16	0	93	329
Total Volume	169	196	7	0	372	40	95	133	0	268	30	212	67	0	309	5	254	61	0	320	1269
% App Total	45.4%	52.7%	1.9%	0.0%		14.9%	35.4%	49.6%	0.0%		9.7%	68.6%	21.7%	0.0%		1.6%	79.4%	19.1%	0.0%		
PHF	.782	.754	.875	.000	.886	.667	.766	.875	.000	.798	.750	.930	.882	.000	.898	.313	.870	.847	.000	.860	.939

ALL TRAFFIC DATA

City of Tracy
 All Vehicles on Unshifted
 Nothing on Bank 1
 Nothing on Bank 2

(916) 771-8700

orders@atdtraffic.com

File Name : 13-7322-008.ppd

Date : 5/22/2013

Unshifted Count = All Vehicles

START TIME	Lammers Road Southbound					Valpico Road Westbound					Lammers Road Northbound					Eastbound					Total	Utum Total
	LEFT	THRU	RIGHT	UTURNS	APP.TOTAL	LEFT	THRU	RIGHT	UTURNS	APP.TOTAL	LEFT	THRU	RIGHT	UTURNS	APP.TOTAL	LEFT	THRU	RIGHT	UTURNS	APP.TOTAL		
07:00	27	1	0	0	28	0	0	75	0	75	0	1	1	0	2	0	0	0	0	0	105	0
07:15	18	2	0	0	20	0	0	86	0	86	0	2	0	0	2	0	0	0	0	0	108	0
07:30	27	1	0	0	28	2	0	120	0	122	0	3	2	0	5	0	0	0	0	0	155	0
07:45	47	5	0	0	52	0	0	146	0	146	0	1	2	0	3	0	0	0	0	0	201	0
Total	119	9	0	0	128	2	0	427	0	429	0	7	5	0	12	0	0	0	0	0	569	0
08:00	46	0	0	0	46	5	0	120	0	125	0	1	4	0	5	0	0	0	0	0	176	0
08:15	49	1	0	0	50	5	0	41	0	46	0	0	5	0	5	0	0	0	0	0	101	0
08:30	42	4	0	0	46	3	0	49	0	52	0	5	2	0	7	0	0	0	0	0	105	0
08:45	12	4	0	0	16	1	0	43	0	44	0	2	1	0	3	0	0	0	0	0	63	0
Total	149	9	0	0	158	14	0	253	0	267	0	8	12	0	20	0	0	0	0	0	445	0
16:00	66	4	0	0	70	3	0	22	0	25	0	3	6	0	9	0	0	0	0	0	104	0
16:15	67	3	0	0	70	3	0	28	0	31	0	6	3	0	9	0	0	0	0	0	110	0
16:30	68	1	0	0	69	1	0	38	0	39	0	0	4	0	4	0	0	0	0	0	112	0
16:45	86	3	0	0	89	0	0	48	0	48	0	2	3	0	5	0	0	0	0	0	142	0
Total	287	11	0	0	298	7	0	136	0	143	0	11	16	0	27	0	0	0	0	0	468	0
17:00	88	5	0	0	93	2	0	30	0	32	0	4	2	0	6	0	0	0	0	0	131	0
17:15	62	0	0	0	62	2	0	39	0	41	0	3	0	0	3	0	0	0	0	0	106	0
17:30	68	3	0	0	71	1	0	29	0	30	0	2	0	0	2	0	0	0	0	0	103	0
17:45	96	2	0	0	98	0	0	25	0	25	0	3	0	0	3	0	0	0	0	0	126	0
Total	314	10	0	0	324	5	0	123	0	128	0	12	2	0	14	0	0	0	0	0	466	0
Grand Total	869	39	0	0	908	28	0	939	0	967	0	38	35	0	73	0	0	0	0	0	1948	0
Apprch %	95.7%	4.3%	0.0%	0.0%		2.9%	0.0%	97.1%	0.0%		0.0%	52.1%	47.9%	0.0%		0.0%	0.0%	0.0%	0.0%	0.0%		
Total %	44.6%	2.0%	0.0%	0.0%	46.6%	1.4%	0.0%	48.2%	0.0%	49.6%	0.0%	2.0%	1.8%	0.0%	3.7%	0.0%	0.0%	0.0%	0.0%	0.0%	100.0%	

AM PEAK HOUR	Lammers Road Southbound					Valpico Road Westbound					Lammers Road Northbound					Eastbound					Total
	LEFT	THRU	RIGHT	UTURNS	APP.TOTAL	LEFT	THRU	RIGHT	UTURNS	APP.TOTAL	LEFT	THRU	RIGHT	UTURNS	APP.TOTAL	LEFT	THRU	RIGHT	UTURNS	APP.TOTAL	
Peak Hour Analysis From 07:15 to 08:15																					
Peak Hour For Entire Intersection Begins at 07:15																					
07:15	18	2	0	0	20	0	0	86	0	86	0	2	0	0	2	0	0	0	0	0	108
07:30	27	1	0	0	28	2	0	120	0	122	0	3	2	0	5	0	0	0	0	0	155
07:45	47	5	0	0	52	0	0	146	0	146	0	1	2	0	3	0	0	0	0	0	201
08:00	46	0	0	0	46	5	0	120	0	125	0	1	4	0	5	0	0	0	0	0	176
Total Volume	138	8	0	0	146	7	0	472	0	479	0	7	8	0	15	0	0	0	0	0	640
% App Total	94.5%	5.5%	0.0%	0.0%		1.5%	0.0%	98.5%	0.0%		0.0%	46.7%	53.3%	0.0%		0.0%	0.0%	0.0%	0.0%	0.0%	
PHF	.734	.400	.000	.000	.702	.350	.000	.808	.000	.820	.000	.583	.500	.000	.750	.000	.000	.000	.000	.000	.796

PM PEAK HOUR	Lammers Road Southbound					Valpico Road Westbound					Lammers Road Northbound					Eastbound					Total
	LEFT	THRU	RIGHT	UTURNS	APP.TOTAL	LEFT	THRU	RIGHT	UTURNS	APP.TOTAL	LEFT	THRU	RIGHT	UTURNS	APP.TOTAL	LEFT	THRU	RIGHT	UTURNS	APP.TOTAL	
Peak Hour Analysis From 17:00 to 18:00																					
Peak Hour For Entire Intersection Begins at 17:00																					
17:00	88	5	0	0	93	2	0	30	0	32	0	4	2	0	6	0	0	0	0	0	131
17:15	62	0	0	0	62	2	0	39	0	41	0	3	0	0	3	0	0	0	0	0	106
17:30	68	3	0	0	71	1	0	29	0	30	0	2	0	0	2	0	0	0	0	0	103
17:45	96	2	0	0	98	0	0	25	0	25	0	3	0	0	3	0	0	0	0	0	126
Total Volume	314	10	0	0	324	5	0	123	0	128	0	12	2	0	14	0	0	0	0	0	466
% App Total	96.9%	3.1%	0.0%	0.0%		3.9%	0.0%	96.1%	0.0%		0.0%	85.7%	14.3%	0.0%		0.0%	0.0%	0.0%	0.0%	0.0%	
PHF	.818	.500	.000	.000	.827	.625	.000	.788	.000	.780	.000	.750	.250	.000	.583	.000	.000	.000	.000	.000	.889

ALL TRAFFIC DATA

City of Tracy
 All Vehicles on Unshifted
 Nothing on Bank 1
 Nothing on Bank 2

(916) 771-8700

orders@atdtraffic.com

File Name : 13-7322-009 Corral Hollow Road-Schulte Road.ppd

Date : 5/22/2013

Unshifted Count = All Vehicles

START TIME	Corral Hollow Road Southbound					Schulte Road Westbound					Corral Hollow Road Northbound					Schulte Road Eastbound					Total	Utum Total
	LEFT	THRU	RIGHT	UTURNS	APP.TOTAL	LEFT	THRU	RIGHT	UTURNS	APP.TOTAL	LEFT	THRU	RIGHT	UTURNS	APP.TOTAL	LEFT	THRU	RIGHT	UTURNS	APP.TOTAL		
07:00	23	53	6	0	82	24	5	61	0	90	1	68	11	0	80	13	8	2	0	23	275	0
07:15	29	44	14	0	87	25	3	105	0	133	1	100	7	0	108	19	9	5	0	33	361	0
07:30	30	82	16	0	128	26	18	94	0	138	3	164	13	0	180	31	10	4	0	45	491	0
07:45	45	90	43	0	178	59	26	115	0	200	3	129	27	0	159	46	19	5	0	70	607	0
Total	127	269	79	0	475	134	52	375	0	561	8	461	58	0	527	109	46	16	0	171	1734	0
08:00	96	137	43	0	276	53	20	133	0	206	6	127	23	0	156	49	28	2	0	79	717	0
08:15	65	79	13	0	157	19	18	122	0	159	5	143	8	0	156	50	15	3	0	68	540	0
08:30	44	57	8	0	109	14	7	108	0	129	0	105	13	0	118	18	7	4	0	29	385	0
08:45	42	56	7	0	105	11	7	82	0	100	3	104	13	0	120	22	9	4	0	35	360	0
Total	247	329	71	0	647	97	52	445	0	594	14	479	57	0	550	139	59	13	0	211	2002	0
16:00	132	143	26	0	301	16	18	76	0	110	3	105	22	0	130	17	8	1	0	26	567	0
16:15	138	122	18	0	278	15	17	83	0	115	2	114	20	0	136	15	13	0	0	28	557	0
16:30	125	171	15	0	311	17	17	94	0	128	3	115	22	0	140	18	9	3	0	30	609	0
16:45	114	154	14	0	282	15	5	85	0	105	1	108	19	0	128	16	16	6	0	38	553	0
Total	509	590	73	0	1172	63	57	338	0	458	9	442	83	0	534	66	46	10	0	122	2286	0
17:00	126	143	23	0	292	10	20	69	0	99	7	131	16	0	154	14	12	8	0	34	579	0
17:15	113	150	22	0	285	13	12	92	0	117	3	112	21	0	136	9	9	1	0	19	557	0
17:30	117	160	21	0	298	13	12	91	0	116	5	122	21	0	148	23	9	3	0	35	597	0
17:45	152	166	19	0	337	14	12	74	0	100	8	109	24	0	141	18	4	3	0	25	603	0
Total	508	619	85	0	1212	50	56	326	0	432	23	474	82	0	579	64	34	15	0	113	2336	0
Grand Total	1391	1807	308	0	3506	344	217	1484	0	2045	54	1856	280	0	2190	378	185	54	0	617	8358	0
Approch %	39.7%	51.5%	8.8%	0.0%		16.8%	10.6%	72.6%	0.0%		2.5%	84.7%	12.8%	0.0%		61.3%	30.0%	8.8%	0.0%			
Total %	16.6%	21.6%	3.7%	0.0%	41.9%	4.1%	2.6%	17.8%	0.0%	24.5%	0.6%	22.2%	3.4%	0.0%	26.2%	4.5%	2.2%	0.6%	0.0%	7.4%	100.0%	

AM PEAK HOUR	Corral Hollow Road Southbound					Schulte Road Westbound					Corral Hollow Road Northbound					Schulte Road Eastbound					Total
	LEFT	THRU	RIGHT	UTURNS	APP.TOTAL	LEFT	THRU	RIGHT	UTURNS	APP.TOTAL	LEFT	THRU	RIGHT	UTURNS	APP.TOTAL	LEFT	THRU	RIGHT	UTURNS	APP.TOTAL	
Peak Hour Analysis From 07:30 to 08:30																					
Peak Hour For Entire Intersection Begins at 07:30																					
07:30	30	82	16	0	128	26	18	94	0	138	3	164	13	0	180	31	10	4	0	45	491
07:45	45	90	43	0	178	59	26	115	0	200	3	129	27	0	159	46	19	5	0	70	607
08:00	96	137	43	0	276	53	20	133	0	206	6	127	23	0	156	49	28	2	0	79	717
08:15	65	79	13	0	157	19	18	122	0	159	5	143	8	0	156	50	15	3	0	68	540
Total Volume	236	388	115	0	739	157	82	464	0	703	17	563	71	0	651	176	72	14	0	262	2355
% App Total	31.9%	52.5%	15.6%	0.0%		22.3%	11.7%	66.0%	0.0%		2.6%	86.5%	10.9%	0.0%		67.2%	27.5%	5.3%	0.0%		
PHF	.615	.708	.669	.000	.669	.665	.788	.872	.000	.853	.708	.858	.657	.000	.904	.880	.643	.700	.000	.829	.821

PM PEAK HOUR	Corral Hollow Road Southbound					Schulte Road Westbound					Corral Hollow Road Northbound					Schulte Road Eastbound					Total
	LEFT	THRU	RIGHT	UTURNS	APP.TOTAL	LEFT	THRU	RIGHT	UTURNS	APP.TOTAL	LEFT	THRU	RIGHT	UTURNS	APP.TOTAL	LEFT	THRU	RIGHT	UTURNS	APP.TOTAL	
Peak Hour Analysis From 17:00 to 18:00																					
Peak Hour For Entire Intersection Begins at 17:00																					
17:00	126	143	23	0	292	10	20	69	0	99	7	131	16	0	154	14	12	8	0	34	579
17:15	113	150	22	0	285	13	12	92	0	117	3	112	21	0	136	9	9	1	0	19	557
17:30	117	160	21	0	298	13	12	91	0	116	5	122	21	0	148	23	9	3	0	35	597
17:45	152	166	19	0	337	14	12	74	0	100	8	109	24	0	141	18	4	3	0	25	603
Total Volume	508	619	85	0	1212	50	56	326	0	432	23	474	82	0	579	64	34	15	0	113	2336
% App Total	41.9%	51.1%	7.0%	0.0%		11.6%	13.0%	75.5%	0.0%		4.0%	81.9%	14.2%	0.0%		56.6%	30.1%	13.3%	0.0%		
PHF	.836	.932	.924	.000	.899	.893	.700	.886	.000	.923	.719	.905	.854	.000	.940	.696	.708	.469	.000	.807	.968

ALL TRAFFIC DATA

City of Tracy
 All Vehicles on Unshifted
 Nothing on Bank 1
 Nothing on Bank 2

(916) 771-8700
orders@atdtraffic.com

File Name : 13-7322-010 Lammers Road-Schulte Road.ppd
 Date : 5/22/2013

Unshifted Count = All Vehicles

START TIME	Lammers Road Southbound					Dirt Driveway Westbound					Lammers Road Northbound					Schulte Road Eastbound					Total	Utum Total
	LEFT	THRU	RIGHT	UTURNS	APP.TOTAL	LEFT	THRU	RIGHT	UTURNS	APP.TOTAL	LEFT	THRU	RIGHT	UTURNS	APP.TOTAL	LEFT	THRU	RIGHT	UTURNS	APP.TOTAL		
07:00	0	15	19	0	34	0	0	0	0	0	97	13	0	0	110	25	0	20	0	45	189	0
07:15	0	20	24	0	44	0	0	0	0	0	105	37	0	0	142	5	0	6	0	11	197	0
07:30	0	36	23	0	59	0	0	0	0	0	78	77	0	0	155	5	0	2	0	7	221	0
07:45	0	62	13	0	75	0	0	0	0	0	35	140	0	0	175	13	0	13	0	26	276	0
Total	0	133	79	0	212	0	0	0	0	0	315	267	0	0	582	48	0	41	0	89	883	0
08:00	0	58	17	0	75	0	0	0	0	0	12	164	0	0	176	31	0	8	0	39	290	0
08:15	0	78	15	0	93	0	0	0	0	0	26	152	0	0	178	31	0	10	0	41	312	0
08:30	0	54	11	0	65	0	0	0	0	0	35	38	0	0	73	3	0	13	0	16	154	0
08:45	0	14	6	0	20	0	0	0	0	0	37	25	0	0	62	4	0	12	0	16	98	0
Total	0	204	49	0	253	0	0	0	0	0	110	379	0	0	489	69	0	43	0	112	854	0
16:00	0	29	3	0	32	0	0	0	0	0	14	20	0	0	34	20	0	62	0	82	148	0
16:15	0	32	5	0	37	0	0	0	0	0	19	22	0	0	41	16	0	69	0	85	163	0
16:30	0	36	10	0	46	0	0	0	0	0	27	22	0	0	49	23	0	72	0	95	190	0
16:45	0	37	7	0	44	0	0	0	0	0	31	27	0	0	58	16	0	83	0	99	201	0
Total	0	134	25	0	159	0	0	0	0	0	91	91	0	0	182	75	0	286	0	361	702	0
17:00	0	51	2	0	53	0	0	0	0	0	18	27	0	0	45	27	0	90	0	117	215	0
17:15	0	24	3	0	27	0	0	0	0	0	19	31	0	0	50	13	1	70	0	84	161	0
17:30	0	30	7	0	37	0	0	0	0	0	19	21	0	0	40	23	0	90	0	113	190	0
17:45	0	44	1	0	45	0	0	0	0	0	15	26	0	0	41	42	0	86	0	128	214	0
Total	0	149	13	0	162	0	0	0	0	0	71	105	0	0	176	105	1	336	0	442	780	0
Grand Total	0	620	166	0	786	0	0	0	0	0	587	842	0	0	1429	297	1	706	0	1004	3219	0
Apprch %	0.0%	78.9%	21.1%	0.0%		0.0%	0.0%	0.0%	0.0%		41.1%	58.9%	0.0%	0.0%		29.6%	0.1%	70.3%	0.0%			
Total %	0.0%	19.3%	5.2%	0.0%	24.4%	0.0%	0.0%	0.0%	0.0%	0.0%	18.2%	26.2%	0.0%	0.0%	44.4%	9.2%	0.0%	21.9%	0.0%	31.2%	100.0%	

AM PEAK HOUR	Lammers Road Southbound					Dirt Driveway Westbound					Lammers Road Northbound					Schulte Road Eastbound					Total
	LEFT	THRU	RIGHT	UTURNS	APP.TOTAL	LEFT	THRU	RIGHT	UTURNS	APP.TOTAL	LEFT	THRU	RIGHT	UTURNS	APP.TOTAL	LEFT	THRU	RIGHT	UTURNS	APP.TOTAL	
Peak Hour Analysis From 07:30 to 08:30																					
Peak Hour For Entire Intersection Begins at 07:30																					
07:30	0	36	23	0	59	0	0	0	0	0	78	77	0	0	155	5	0	2	0	7	221
07:45	0	62	13	0	75	0	0	0	0	0	35	140	0	0	175	13	0	13	0	26	276
08:00	0	58	17	0	75	0	0	0	0	0	12	164	0	0	176	31	0	8	0	39	290
08:15	0	78	15	0	93	0	0	0	0	0	26	152	0	0	178	31	0	10	0	41	312
Total Volume	0	234	68	0	302	0	0	0	0	0	151	533	0	0	684	80	0	33	0	113	1099
% App Total	0.0%	77.5%	22.5%	0.0%		0.0%	0.0%	0.0%	0.0%		22.1%	77.9%	0.0%	0.0%		70.8%	0.0%	29.2%	0.0%		
PHF	.000	.750	.739	.000	.812	.000	.000	.000	.000	.000	.484	.813	.000	.000	.961	.645	.000	.635	.000	.689	.881

PM PEAK HOUR	Lammers Road Southbound					Dirt Driveway Westbound					Lammers Road Northbound					Schulte Road Eastbound					Total
	LEFT	THRU	RIGHT	UTURNS	APP.TOTAL	LEFT	THRU	RIGHT	UTURNS	APP.TOTAL	LEFT	THRU	RIGHT	UTURNS	APP.TOTAL	LEFT	THRU	RIGHT	UTURNS	APP.TOTAL	
Peak Hour Analysis From 17:00 to 18:00																					
Peak Hour For Entire Intersection Begins at 17:00																					
17:00	0	51	2	0	53	0	0	0	0	0	18	27	0	0	45	27	0	90	0	117	215
17:15	0	24	3	0	27	0	0	0	0	0	19	31	0	0	50	13	1	70	0	84	161
17:30	0	30	7	0	37	0	0	0	0	0	19	21	0	0	40	23	0	90	0	113	190
17:45	0	44	1	0	45	0	0	0	0	0	15	26	0	0	41	42	0	86	0	128	214
Total Volume	0	149	13	0	162	0	0	0	0	0	71	105	0	0	176	105	1	336	0	442	780
% App Total	0.0%	92.0%	8.0%	0.0%		0.0%	0.0%	0.0%	0.0%		40.3%	59.7%	0.0%	0.0%		23.8%	0.2%	76.0%	0.0%		
PHF	.000	.730	.464	.000	.764	.000	.000	.000	.000	.000	.934	.847	.000	.000	.880	.625	.250	.933	.000	.863	.907

ALL TRAFFIC DATA

City of Tracy
 All Vehicles on Unshifted
 Nothing on Bank 1
 Nothing on Bank 2

(916) 771-8700
orders@atdtraffic.com

File Name : C:\Users\Sac - 3\Desktop\13-7322 Tracy\csvs\13-7322-012
 Date : 5/22/2013

Unshifted Count = All Vehicles

START TIME	Lammers Road Southbound					11th Street Westbound					Lammers Road Northbound					11th Street Eastbound					Total	Utum Total
	LEFT	THRU	RIGHT	UTURNS	APP.TOTAL	LEFT	THRU	RIGHT	UTURNS	APP.TOTAL	LEFT	THRU	RIGHT	UTURNS	APP.TOTAL	LEFT	THRU	RIGHT	UTURNS	APP.TOTAL		
07:00	6	8	17	0	31	28	243	8	0	279	6	16	27	0	49	1	36	3	0	40	399	0
07:15	9	15	20	0	44	49	204	2	0	255	14	13	45	0	72	3	40	10	0	53	424	0
07:30	20	11	25	0	56	58	201	14	0	273	18	9	69	0	96	7	66	12	0	85	510	0
07:45	36	21	14	0	71	95	211	22	0	328	21	15	90	0	126	6	96	42	0	144	669	0
Total	71	55	76	0	202	230	859	46	0	1135	59	53	231	0	343	17	238	67	0	322	2002	0
08:00	19	60	18	0	97	122	234	34	0	390	35	17	114	0	166	10	69	55	0	134	787	0
08:15	4	34	16	0	54	84	213	16	0	313	42	31	122	0	195	7	69	54	0	130	692	0
08:30	3	3	10	0	16	18	204	17	0	239	20	18	42	0	80	8	72	13	0	93	428	0
08:45	6	7	15	0	28	15	176	5	0	196	7	12	16	0	35	2	58	5	0	65	324	0
Total	32	104	59	0	195	239	827	72	0	1138	104	78	294	0	476	27	268	127	0	422	2231	0
16:00	11	10	7	0	28	61	104	17	0	182	7	14	88	0	109	20	263	32	0	315	634	0
16:15	16	18	5	0	39	35	117	16	0	168	15	23	58	0	96	21	240	24	0	285	588	0
16:30	20	17	13	0	50	29	93	16	0	138	10	24	73	0	107	27	282	17	0	326	621	0
16:45	10	23	8	0	41	41	83	16	0	140	11	19	82	0	112	28	290	17	0	335	628	0
Total	57	68	33	0	158	166	397	65	0	628	43	80	301	0	424	96	1075	90	0	1261	2471	0
17:00	15	25	7	0	47	27	79	13	0	119	7	10	49	0	66	24	273	10	0	307	539	0
17:15	14	17	6	0	37	28	102	21	0	151	7	20	34	0	61	32	307	16	0	355	604	0
17:30	12	19	1	0	32	17	91	17	0	125	3	18	39	0	60	22	291	23	0	336	553	0
17:45	20	17	3	0	40	21	71	14	0	106	4	13	31	0	48	17	329	23	0	369	563	0
Total	61	78	17	0	156	93	343	65	0	501	21	61	153	0	235	95	1200	72	0	1367	2259	0
Grand Total	221	305	185	0	711	728	2426	248	0	3402	227	272	979	0	1478	235	2781	356	0	3372	8963	0
Apprch %	31.1%	42.9%	26.0%	0.0%		21.4%	71.3%	7.3%	0.0%		15.4%	18.4%	66.2%	0.0%		7.0%	82.5%	10.6%	0.0%			
Total %	2.5%	3.4%	2.1%	0.0%	7.9%	8.1%	27.1%	2.8%	0.0%	38.0%	2.5%	3.0%	10.9%	0.0%	16.5%	2.6%	31.0%	4.0%	0.0%	37.6%	100.0%	

AM PEAK HOUR	Lammers Road Southbound					11th Street Westbound					Lammers Road Northbound					11th Street Eastbound					Total	
	LEFT	THRU	RIGHT	UTURNS	APP.TOTAL	LEFT	THRU	RIGHT	UTURNS	APP.TOTAL	LEFT	THRU	RIGHT	UTURNS	APP.TOTAL	LEFT	THRU	RIGHT	UTURNS	APP.TOTAL		
Peak Hour Analysis From 07:30 to 08:30																						
Peak Hour For Entire Intersection Begins at 07:30																						
07:30	20	11	25	0	56	58	201	14	0	273	18	9	69	0	96	7	66	12	0	85	510	
07:45	36	21	14	0	71	95	211	22	0	328	21	15	90	0	126	6	96	42	0	144	669	
08:00	19	60	18	0	97	122	234	34	0	390	35	17	114	0	166	10	69	55	0	134	787	
08:15	4	34	16	0	54	84	213	16	0	313	42	31	122	0	195	7	69	54	0	130	692	
Total Volume	79	126	73	0	278	359	859	86	0	1304	116	72	395	0	583	30	300	163	0	493	2658	
% App Total	28.4%	45.3%	26.3%	0.0%		27.5%	65.9%	6.6%	0.0%		19.9%	12.3%	67.8%	0.0%		6.1%	60.9%	33.1%	0.0%			
PHF	.549	.525	.730	.000	.716	.736	.918	.632	.000	.836	.690	.581	.809	.000	.747	.750	.781	.741	.000	.856	.844	

PM PEAK HOUR	Lammers Road Southbound					11th Street Westbound					Lammers Road Northbound					11th Street Eastbound					Total	
	LEFT	THRU	RIGHT	UTURNS	APP.TOTAL	LEFT	THRU	RIGHT	UTURNS	APP.TOTAL	LEFT	THRU	RIGHT	UTURNS	APP.TOTAL	LEFT	THRU	RIGHT	UTURNS	APP.TOTAL		
Peak Hour Analysis From 16:00 to 17:00																						
Peak Hour For Entire Intersection Begins at 16:00																						
16:00	11	10	7	0	28	61	104	17	0	182	7	14	88	0	109	20	263	32	0	315	634	
16:15	16	18	5	0	39	35	117	16	0	168	15	23	58	0	96	21	240	24	0	285	588	
16:30	20	17	13	0	50	29	93	16	0	138	10	24	73	0	107	27	282	17	0	326	621	
16:45	10	23	8	0	41	41	83	16	0	140	11	19	82	0	112	28	290	17	0	335	628	
Total Volume	57	68	33	0	158	166	397	65	0	628	43	80	301	0	424	96	1075	90	0	1261	2471	
% App Total	36.1%	43.0%	20.9%	0.0%		26.4%	63.2%	10.4%	0.0%		10.1%	18.9%	71.0%	0.0%		7.6%	85.2%	7.1%	0.0%			
PHF	.713	.739	.635	.000	.790	.680	.848	.956	.000	.863	.717	.833	.855	.000	.946	.857	.927	.703	.000	.941	.974	

ALL TRAFFIC DATA

City of Tracy
 All Vehicles on Unshifted
 Buses on Bank 1
 FHWA Class 5 and above on Bank 2

(916) 771-8700
orders@atdtraffic.com

File Name : 13-7532-013 Mountain House Pkwy-I-580 EB Ramps.ppd
 Date : 9/24/2013

Unshifted Count = All Vehicles

START TIME	Mountain House Pkwy Southbound					I-580 EB Ramps Westbound					Mountain House Pkwy Northbound					I-580 EB Ramps Eastbound					Total	Ped Total
	LEFT	THRU	RIGHT	PEDS	APP.TOTAL	LEFT	THRU	RIGHT	PEDS	APP.TOTAL	LEFT	THRU	RIGHT	PEDS	APP.TOTAL	LEFT	THRU	RIGHT	PEDS	APP.TOTAL		
07:00	14	207	0	0	221	0	0	0	0	0	0	5	3	0	8	6	1	4	0	11	240	0
07:15	15	209	0	0	224	0	0	0	0	0	0	2	3	0	5	21	0	4	0	25	254	0
07:30	15	145	0	0	160	0	0	0	0	0	0	5	3	0	8	21	0	3	0	24	192	0
07:45	28	124	0	0	152	0	0	0	0	0	0	8	2	0	10	24	1	2	0	27	189	0
Total	72	685	0	0	757	0	0	0	0	0	0	20	11	0	31	72	2	13	0	87	875	0
08:00	20	92	0	0	112	0	0	0	0	0	0	4	3	0	7	25	0	2	0	27	146	0
08:15	21	64	0	0	85	0	0	0	0	0	0	3	2	0	5	22	0	3	0	25	115	0
08:30	22	55	0	0	77	0	0	0	0	0	0	10	2	0	12	23	1	4	0	28	117	0
08:45	27	32	0	0	59	0	0	0	0	0	0	8	0	0	8	25	1	2	0	28	95	0
Total	90	243	0	0	333	0	0	0	0	0	0	25	7	0	32	95	2	11	0	108	473	0
16:00	49	7	0	0	56	0	0	0	0	0	0	68	52	0	120	41	2	17	0	60	236	0
16:15	45	6	0	0	51	0	0	0	0	0	0	79	50	0	129	40	2	14	0	56	236	0
16:30	57	14	0	0	71	0	0	0	0	0	0	96	56	0	152	39	0	18	0	57	280	0
16:45	56	8	0	0	64	0	0	0	0	0	0	113	71	0	184	43	2	16	0	61	309	0
Total	207	35	0	0	242	0	0	0	0	0	0	356	229	0	585	163	6	65	0	234	1061	0
17:00	48	6	0	0	54	0	0	0	0	0	0	117	52	0	169	55	1	15	0	71	294	0
17:15	34	3	0	0	37	0	0	0	0	0	0	141	61	0	202	49	1	15	0	65	304	0
17:30	28	10	0	0	38	0	0	0	0	0	0	118	57	0	175	39	1	15	0	55	268	0
17:45	33	4	0	0	37	0	0	0	0	0	0	109	57	0	166	48	1	8	0	57	260	0
Total	143	23	0	0	166	0	0	0	0	0	0	485	227	0	712	191	4	53	0	248	1126	0
Grand Total	512	986	0	0	1498	0	0	0	0	0	0	886	474	0	1360	521	14	142	0	677	3535	0
Apprch %	34.2%	65.8%	0.0%			0.0%	0.0%	0.0%			0.0%	65.1%	34.9%			77.0%	2.1%	21.0%				
Total %	14.5%	27.9%	0.0%		42.4%	0.0%	0.0%	0.0%		0.0%	0.0%	25.1%	13.4%		38.5%	14.7%	0.4%	4.0%		19.2%	100.0%	

AM PEAK HOUR	Mountain House Pkwy Southbound					I-580 EB Ramps Westbound					Mountain House Pkwy Northbound					I-580 EB Ramps Eastbound					Total	
	LEFT	THRU	RIGHT		APP.TOTAL	LEFT	THRU	RIGHT		APP.TOTAL	LEFT	THRU	RIGHT		APP.TOTAL	LEFT	THRU	RIGHT		APP.TOTAL		
Peak Hour Analysis From 07:00 to 08:00																						
Peak Hour For Entire Intersection Begins at 07:00																						
07:00	14	207	0		221	0	0	0		0	0	5	3		8	6	1	4		11	240	
07:15	15	209	0		224	0	0	0		0	0	2	3		5	21	0	4		25	254	
07:30	15	145	0		160	0	0	0		0	0	5	3		8	21	0	3		24	192	
07:45	28	124	0		152	0	0	0		0	0	8	2		10	24	1	2		27	189	
Total Volume	72	685	0		757	0	0	0		0	0	20	11		31	72	2	13		87	875	
% App Total	9.5%	90.5%	0.0%			0.0%	0.0%	0.0%			0.0%	64.5%	35.5%			82.8%	2.3%	14.9%				
PHF	.643	.819	.000		.845	.000	.000	.000		.000	.000	.625	.917		.775	.750	.500	.813		.806	.861	

PM PEAK HOUR	Mountain House Pkwy Southbound					I-580 EB Ramps Westbound					Mountain House Pkwy Northbound					I-580 EB Ramps Eastbound					Total	
	LEFT	THRU	RIGHT		APP.TOTAL	LEFT	THRU	RIGHT		APP.TOTAL	LEFT	THRU	RIGHT		APP.TOTAL	LEFT	THRU	RIGHT		APP.TOTAL		
Peak Hour Analysis From 16:30 to 17:30																						
Peak Hour For Entire Intersection Begins at 16:30																						
16:30	57	14	0		71	0	0	0		0	0	96	56		152	39	0	18		57	280	
16:45	56	8	0		64	0	0	0		0	0	113	71		184	43	2	16		61	309	
17:00	48	6	0		54	0	0	0		0	0	117	52		169	55	1	15		71	294	
17:15	34	3	0		37	0	0	0		0	0	141	61		202	49	1	15		65	304	
Total Volume	195	31	0		226	0	0	0		0	0	467	240		707	186	4	64		254	1187	
% App Total	86.3%	13.7%	0.0%			0.0%	0.0%	0.0%			0.0%	66.1%	33.9%			73.2%	1.6%	25.2%				
PHF	.855	.554	.000		.796	.000	.000	.000		.000	.000	.828	.845		.875	.845	.500	.889		.894	.960	

ALL TRAFFIC DATA

City of Tracy
 All Vehicles on Unshifted
 Buses on Bank 1
 FHWA Class 5 and above on Bank 2

(916) 771-8700

orders@atdtraffic.com

File Name : 13-7532-013 Mountain House Pkwy-I-580 EB Ramps.ppd

Date : 9/24/2013

Bank 1 Count = Buses

START TIME	Mountain House Pkwy Southbound					I-580 EB Ramps Westbound					Mountain House Pkwy Northbound					I-580 EB Ramps Eastbound					Total	Ped Total	
	LEFT	THRU	RIGHT	PEDS	APP.TOTAL	LEFT	THRU	RIGHT	PEDS	APP.TOTAL	LEFT	THRU	RIGHT	PEDS	APP.TOTAL	LEFT	THRU	RIGHT	PEDS	APP.TOTAL			
07:00	0	0	0	0	0	0	0	0	0	0	0	0	0	0	0	0	0	0	0	0	0	0	0
07:15	0	0	0	0	0	0	0	0	0	0	0	0	0	0	0	0	0	0	0	0	0	0	0
07:30	0	0	0	0	0	0	0	0	0	0	0	0	0	0	0	0	0	0	0	0	0	0	0
07:45	0	0	0	0	0	0	0	0	0	0	0	0	0	0	0	0	0	0	0	0	0	0	0
Total	0	0	0	0	0	0	0	0	0	0	0	0	0	0	0	0	0	0	0	0	0	0	0
08:00	0	0	0	0	0	0	0	0	0	0	0	0	0	0	0	0	0	0	0	0	0	0	0
08:15	0	0	0	0	0	0	0	0	0	0	0	0	0	0	0	0	0	0	0	0	0	0	0
08:30	0	0	0	0	0	0	0	0	0	0	0	0	0	0	0	0	0	0	0	0	0	0	0
08:45	0	0	0	0	0	0	0	0	0	0	0	0	0	0	0	0	0	0	0	0	0	0	0
Total	0	0	0	0	0	0	0	0	0	0	0	0	0	0	0	0	0	0	0	0	0	0	0
16:00	0	0	0	0	0	0	0	0	0	0	0	0	0	0	0	0	0	0	0	0	0	0	0
16:15	0	0	0	0	0	0	0	0	0	0	0	0	0	0	0	0	0	0	0	0	0	0	0
16:30	0	0	0	0	0	0	0	0	0	0	0	0	0	0	0	0	0	0	0	0	0	0	0
16:45	0	0	0	0	0	0	0	0	0	0	0	0	0	0	0	0	0	0	0	0	0	0	0
Total	0	0	0	0	0	0	0	0	0	0	0	0	0	0	0	0	0	0	0	0	0	0	0
17:00	0	0	0	0	0	0	0	0	0	0	0	0	0	0	0	0	0	0	0	0	0	0	0
17:15	0	0	0	0	0	0	0	0	0	0	0	0	0	0	0	0	0	0	0	0	0	0	0
17:30	0	0	0	0	0	0	0	0	0	0	0	0	0	0	0	0	0	0	0	0	0	0	0
17:45	0	0	0	0	0	0	0	0	0	0	0	0	0	0	0	0	0	0	0	0	0	0	0
Total	0	0	0	0	0	0	0	0	0	0	0	0	0	0	0	0	0	0	0	0	0	0	0
Grand Total	0	0	0	0	0	0	0	0	0	0	0	0	0	0	0	0	0	0	0	0	0	0	0
Apprch %	0.0%	0.0%	0.0%			0.0%	0.0%	0.0%			0.0%	0.0%	0.0%			0.0%	0.0%	0.0%			0.0%	0.0%	0.0%
Total %	0.0%	0.0%	0.0%		0.0%	0.0%	0.0%	0.0%		0.0%	0.0%	0.0%		0.0%	0.0%	0.0%	0.0%		0.0%		0.0%	0.0%	0.0%

AM PEAK HOUR	Mountain House Pkwy Southbound					I-580 EB Ramps Westbound					Mountain House Pkwy Northbound					I-580 EB Ramps Eastbound					Total	
START TIME	LEFT	THRU	RIGHT		APP.TOTAL	LEFT	THRU	RIGHT		APP.TOTAL	LEFT	THRU	RIGHT		APP.TOTAL	LEFT	THRU	RIGHT		APP.TOTAL	Total	
Peak Hour Analysis From 07:00 to 08:00																						
Peak Hour For Entire Intersection Begins at 07:00																						
07:00	0	0	0		0	0	0	0		0	0	0	0		0	0	0	0		0	0	
07:15	0	0	0		0	0	0	0		0	0	0	0		0	0	0	0		0	0	
07:30	0	0	0		0	0	0	0		0	0	0	0		0	0	0	0		0	0	
07:45	0	0	0		0	0	0	0		0	0	0	0		0	0	0	0		0	0	
Total Volume	0	0	0		0	0	0	0		0	0	0	0		0	0	0	0		0	0	
% App Total	0.0%	0.0%	0.0%			0.0%	0.0%	0.0%			0.0%	0.0%	0.0%			0.0%	0.0%	0.0%			0.0%	0.0%
PHF	.000	.000	.000		.000	.000	.000	.000		.000	.000	.000	.000		.000	.000	.000	.000		.000	.000	

PM PEAK HOUR	Mountain House Pkwy Southbound					I-580 EB Ramps Westbound					Mountain House Pkwy Northbound					I-580 EB Ramps Eastbound					Total	
START TIME	LEFT	THRU	RIGHT		APP.TOTAL	LEFT	THRU	RIGHT		APP.TOTAL	LEFT	THRU	RIGHT		APP.TOTAL	LEFT	THRU	RIGHT		APP.TOTAL	Total	
Peak Hour Analysis From 16:30 to 17:30																						
Peak Hour For Entire Intersection Begins at 16:30																						
16:30	0	0	0		0	0	0	0		0	0	0	0		0	0	0	0		0	0	
16:45	0	0	0		0	0	0	0		0	0	0	0		0	0	0	0		0	0	
17:00	0	0	0		0	0	0	0		0	0	0	0		0	0	0	0		0	0	
17:15	0	0	0		0	0	0	0		0	0	0	0		0	0	0	0		0	0	
Total Volume	0	0	0		0	0	0	0		0	0	0	0		0	0	0	0		0	0	
% App Total	0.0%	0.0%	0.0%			0.0%	0.0%	0.0%			0.0%	0.0%	0.0%			0.0%	0.0%	0.0%			0.0%	0.0%
PHF	.000	.000	.000		.000	.000	.000	.000		.000	.000	.000	.000		.000	.000	.000	.000		.000	.000	

ALL TRAFFIC DATA

(916) 771-8700

orders@atdtraffic.com

File Name : 13-7532-013 Mountain House Pkwy-I-580 EB Ramps.ppd

Date : 9/24/2013

City of Tracy

All Vehicles on Unshifted

Buses on Bank 1

FHWA Class 5 and above on Bank 2

ank 2 Count = FHWA Class 5 and above

START TIME	Mountain House Pkwy Southbound					I-580 EB Ramps Westbound					Mountain House Pkwy Northbound					I-580 EB Ramps Eastbound					Total	Ped Total
	LEFT	THRU	RIGHT	PEDS	APP.TOTAL	LEFT	THRU	RIGHT	PEDS	APP.TOTAL	LEFT	THRU	RIGHT	PEDS	APP.TOTAL	LEFT	THRU	RIGHT	PEDS	APP.TOTAL		
07:00	4	1	0	0	5	0	0	0	0	0	0	0	0	0	0	4	0	0	0	4	9	0
07:15	8	0	0	0	8	0	0	0	0	0	0	0	1	0	1	7	0	0	0	7	16	0
07:30	7	2	0	0	9	0	0	0	0	0	0	2	0	0	2	7	0	1	0	8	19	0
07:45	15	2	0	0	17	0	0	0	0	0	0	2	2	0	4	5	1	0	0	6	27	0
Total	34	5	0	0	39	0	0	0	0	0	0	4	3	0	7	23	1	1	0	25	71	0
08:00	11	1	0	0	12	0	0	0	0	0	0	2	0	0	2	5	0	0	0	5	19	0
08:15	7	2	0	0	9	0	0	0	0	0	0	1	0	0	1	5	0	0	0	5	15	0
08:30	14	2	0	0	16	0	0	0	0	0	0	4	0	0	4	9	1	0	0	10	30	0
08:45	14	1	0	0	15	0	0	0	0	0	0	0	0	0	0	12	1	0	0	13	28	0
Total	46	6	0	0	52	0	0	0	0	0	0	7	0	0	7	31	2	0	0	33	92	0
16:00	7	2	0	0	9	0	0	0	0	0	0	1	1	0	2	7	2	0	0	9	20	0
16:15	5	1	0	0	6	0	0	0	0	0	0	1	0	0	1	6	0	1	0	7	14	0
16:30	4	1	0	0	5	0	0	0	0	0	0	2	0	0	2	3	0	0	0	3	10	0
16:45	9	0	0	0	9	0	0	0	0	0	0	1	2	0	3	3	1	0	0	4	16	0
Total	25	4	0	0	29	0	0	0	0	0	0	5	3	0	8	19	3	1	0	23	60	0
17:00	2	1	0	0	3	0	0	0	0	0	0	2	0	0	2	6	0	0	0	6	11	0
17:15	4	0	0	0	4	0	0	0	0	0	0	0	1	0	1	7	1	0	0	8	13	0
17:30	3	2	0	0	5	0	0	0	0	0	0	1	1	0	2	2	0	0	0	2	9	0
17:45	7	1	0	0	8	0	0	0	0	0	0	0	0	0	0	7	0	0	0	7	15	0
Total	16	4	0	0	20	0	0	0	0	0	0	3	2	0	5	22	1	0	0	23	48	0
Grand Total	121	19	0	0	140	0	0	0	0	0	0	19	8	0	27	95	7	2	0	104	271	0
Apprch %	86.4%	13.6%	0.0%			0.0%	0.0%	0.0%			0.0%	70.4%	29.6%			91.3%	6.7%	1.9%				
Total %	44.6%	7.0%	0.0%		51.7%	0.0%	0.0%	0.0%		0.0%	0.0%	7.0%	3.0%		10.0%	35.1%	2.6%	0.7%		38.4%	100.0%	

AM PEAK HOUR	Mountain House Pkwy Southbound					I-580 EB Ramps Westbound					Mountain House Pkwy Northbound					I-580 EB Ramps Eastbound					Total
	LEFT	THRU	RIGHT		APP.TOTAL	LEFT	THRU	RIGHT		APP.TOTAL	LEFT	THRU	RIGHT		APP.TOTAL	LEFT	THRU	RIGHT		APP.TOTAL	
Peak Hour Analysis From 07:00 to 08:00																					
Peak Hour For Entire Intersection Begins at 07:00																					
07:00	4	1	0		5	0	0	0		0	0	0	0		0	4	0	0		4	9
07:15	8	0	0		8	0	0	0		0	0	0	1		1	7	0	0		7	16
07:30	7	2	0		9	0	0	0		0	0	2	0		2	7	0	1		8	19
07:45	15	2	0		17	0	0	0		0	0	2	2		4	5	1	0		6	27
Total Volume	34	5	0		39	0	0	0		0	4	3			7	23	1	1		25	71
% App Total	87.2%	12.8%	0.0%			0.0%	0.0%	0.0%			0.0%	57.1%	42.9%			92.0%	4.0%	4.0%			
PHF	.567	.625	.000		.574	.000	.000	.000		.000	.000	.500	.375		.438	.821	.250	.250		.781	.657

PM PEAK HOUR	Mountain House Pkwy Southbound					I-580 EB Ramps Westbound					Mountain House Pkwy Northbound					I-580 EB Ramps Eastbound					Total
	LEFT	THRU	RIGHT		APP.TOTAL	LEFT	THRU	RIGHT		APP.TOTAL	LEFT	THRU	RIGHT		APP.TOTAL	LEFT	THRU	RIGHT		APP.TOTAL	
Peak Hour Analysis From 16:30 to 17:30																					
Peak Hour For Entire Intersection Begins at 16:30																					
16:30	4	1	0		5	0	0	0		0	0	2	0		2	3	0	0		3	10
16:45	9	0	0		9	0	0	0		0	0	1	2		3	3	1	0		4	16
17:00	2	1	0		3	0	0	0		0	0	2	0		2	6	0	0		6	11
17:15	4	0	0		4	0	0	0		0	0	0	1		1	7	1	0		8	13
Total Volume	19	2	0		21	0	0	0		0	5	3			8	19	2	0		21	50
% App Total	90.5%	9.5%	0.0%			0.0%	0.0%	0.0%			0.0%	62.5%	37.5%			90.5%	9.5%	0.0%			
PHF	.528	.500	.000		.583	.000	.000	.000		.000	.000	.625	.375		.667	.679	.500	.000		.656	.781

ALL TRAFFIC DATA

City of Tracy
 All Vehicles on Unshifted
 Buses on Bank 1
 FHWA Class 5 and above on Bank 2

(916) 771-8700
orders@atdtraffic.com

File Name : 13-7532-014 Mountain House Pkwy-I-580 WB Ramps.ppd
 Date : 9/24/2013

Unshifted Count = All Vehicles

START TIME	Mountain House Pkwy Southbound					I-580 WB Ramps Westbound					Mountain House Pkwy Northbound					I-580 WB Ramps Eastbound					Total	Ped Total
	LEFT	THRU	RIGHT	PEDS	APP.TOTAL	LEFT	THRU	RIGHT	PEDS	APP.TOTAL	LEFT	THRU	RIGHT	PEDS	APP.TOTAL	LEFT	THRU	RIGHT	PEDS	APP.TOTAL		
07:00	0	171	52	0	223	44	1	34	0	79	1	11	0	0	12	0	0	0	0	0	314	0
07:15	0	182	59	0	241	45	1	49	0	95	1	18	0	0	19	0	0	0	0	0	355	0
07:30	0	123	43	0	166	41	0	36	0	77	3	27	0	0	30	0	0	0	0	0	273	0
07:45	0	115	31	0	146	33	0	47	0	80	0	34	0	0	34	0	0	0	0	0	260	0
Total	0	591	185	0	776	163	2	166	0	331	5	90	0	0	95	0	0	0	0	0	1202	0
08:00	0	80	24	0	104	35	1	47	0	83	0	24	0	0	24	0	0	0	0	0	211	0
08:15	0	62	33	0	95	20	1	44	0	65	2	26	0	0	28	0	0	0	0	0	188	0
08:30	0	66	53	0	119	11	0	30	0	41	2	32	0	0	34	0	0	0	0	0	194	0
08:45	0	55	43	0	98	10	0	31	0	41	4	28	0	0	32	0	0	0	0	0	171	0
Total	0	263	153	0	416	76	2	152	0	230	8	110	0	0	118	0	0	0	0	0	764	0
16:00	0	56	23	0	79	2	0	12	0	14	3	100	0	0	103	0	0	0	0	0	196	0
16:15	0	48	27	0	75	1	0	21	0	22	2	123	0	0	125	0	0	0	0	0	222	0
16:30	0	73	43	0	116	2	1	30	0	33	0	130	0	0	130	0	0	0	0	0	279	0
16:45	0	59	31	0	90	1	1	26	0	28	0	161	0	0	161	0	0	0	0	0	279	0
Total	0	236	124	0	360	6	2	89	0	97	5	514	0	0	519	0	0	0	0	0	976	0
17:00	0	52	38	0	90	2	0	16	0	18	3	167	0	0	170	0	0	0	0	0	278	0
17:15	0	33	24	0	57	2	1	17	0	20	1	193	0	0	194	0	0	0	0	0	271	0
17:30	0	40	19	0	59	1	0	17	0	18	1	153	0	0	154	0	0	0	0	0	231	0
17:45	0	34	18	0	52	2	0	20	0	22	1	155	0	0	156	0	0	0	0	0	230	0
Total	0	159	99	0	258	7	1	70	0	78	6	668	0	0	674	0	0	0	0	0	1010	0
Grand Total	0	1249	561	0	1810	252	7	477	0	736	24	1382	0	0	1406	0	0	0	0	0	3952	0
Apprch %	0.0%	69.0%	31.0%			34.2%	1.0%	64.8%			1.7%	98.3%	0.0%			0.0%	0.0%	0.0%				
Total %	0.0%	31.6%	14.2%		45.8%	6.4%	0.2%	12.1%		18.6%	0.6%	35.0%	0.0%		35.6%	0.0%	0.0%	0.0%		0.0%	100.0%	

AM PEAK HOUR	Mountain House Pkwy Southbound					I-580 WB Ramps Westbound					Mountain House Pkwy Northbound					I-580 WB Ramps Eastbound					Total
	LEFT	THRU	RIGHT		APP.TOTAL	LEFT	THRU	RIGHT		APP.TOTAL	LEFT	THRU	RIGHT		APP.TOTAL	LEFT	THRU	RIGHT		APP.TOTAL	
Peak Hour Analysis From 07:00 to 08:00																					
Peak Hour For Entire Intersection Begins at 07:00																					
07:00	0	171	52		223	44	1	34		79	1	11	0		12	0	0	0		0	314
07:15	0	182	59		241	45	1	49		95	1	18	0		19	0	0	0		0	355
07:30	0	123	43		166	41	0	36		77	3	27	0		30	0	0	0		0	273
07:45	0	115	31		146	33	0	47		80	0	34	0		34	0	0	0		0	260
Total Volume	0	591	185		776	163	2	166		331	5	90	0		95	0	0	0		0	1202
% App Total	0.0%	76.2%	23.8%			49.2%	0.6%	50.2%			5.3%	94.7%	0.0%			0.0%	0.0%	0.0%			
PHF	.000	.812	.784		.805	.906	.500	.847		.871	.417	.662	.000		.699	.000	.000	.000		.000	.846

PM PEAK HOUR	Mountain House Pkwy Southbound					I-580 WB Ramps Westbound					Mountain House Pkwy Northbound					I-580 WB Ramps Eastbound					Total
	LEFT	THRU	RIGHT		APP.TOTAL	LEFT	THRU	RIGHT		APP.TOTAL	LEFT	THRU	RIGHT		APP.TOTAL	LEFT	THRU	RIGHT		APP.TOTAL	
Peak Hour Analysis From 16:30 to 17:30																					
Peak Hour For Entire Intersection Begins at 16:30																					
16:30	0	73	43		116	2	1	30		33	0	130	0		130	0	0	0		0	279
16:45	0	59	31		90	1	1	26		28	0	161	0		161	0	0	0		0	279
17:00	0	52	38		90	2	0	16		18	3	167	0		170	0	0	0		0	278
17:15	0	33	24		57	2	1	17		20	1	193	0		194	0	0	0		0	271
Total Volume	0	217	136		353	7	3	89		99	4	651	0		655	0	0	0		0	1107
% App Total	0.0%	61.5%	38.5%			7.1%	3.0%	89.9%			0.6%	99.4%	0.0%			0.0%	0.0%	0.0%			
PHF	.000	.743	.791		.761	.875	.750	.742		.750	.333	.843	.000		.844	.000	.000	.000		.000	.992

ALL TRAFFIC DATA

City of Tracy
 All Vehicles on Unshifted
 Buses on Bank 1
 FHWA Class 5 and above on Bank 2

(916) 771-8700
orders@atdtraffic.com

File Name : 13-7532-014 Mountain House Pkwy-I-580 WB Ramps.ppd
 Date : 9/24/2013

Bank 1 Count = Buses

START TIME	Mountain House Pkwy Southbound					I-580 WB Ramps Westbound					Mountain House Pkwy Northbound					I-580 WB Ramps Eastbound					Total	Ped Total	
	LEFT	THRU	RIGHT	PEDS	APP.TOTAL	LEFT	THRU	RIGHT	PEDS	APP.TOTAL	LEFT	THRU	RIGHT	PEDS	APP.TOTAL	LEFT	THRU	RIGHT	PEDS	APP.TOTAL			
07:00	0	0	0	0	0	0	0	0	0	0	0	0	0	0	0	0	0	0	0	0	0	0	0
07:15	0	0	0	0	0	0	0	0	0	0	0	0	0	0	0	0	0	0	0	0	0	0	0
07:30	0	0	0	0	0	0	0	0	0	0	0	0	0	0	0	0	0	0	0	0	0	0	0
07:45	0	0	0	0	0	0	0	0	0	0	0	0	0	0	0	0	0	0	0	0	0	0	0
Total	0	0	0	0	0	0	0	0	0	0	0	0	0	0	0	0	0	0	0	0	0	0	0
08:00	0	0	0	0	0	0	0	0	0	0	0	0	0	0	0	0	0	0	0	0	0	0	0
08:15	0	0	0	0	0	0	0	0	0	0	0	0	0	0	0	0	0	0	0	0	0	0	0
08:30	0	0	0	0	0	0	0	0	0	0	0	0	0	0	0	0	0	0	0	0	0	0	0
08:45	0	0	0	0	0	0	0	0	0	0	0	0	0	0	0	0	0	0	0	0	0	0	0
Total	0	0	0	0	0	0	0	0	0	0	0	0	0	0	0	0	0	0	0	0	0	0	0
16:00	0	0	0	0	0	0	0	0	0	0	0	0	0	0	0	0	0	0	0	0	0	0	0
16:15	0	0	0	0	0	0	0	0	0	0	0	0	0	0	0	0	0	0	0	0	0	0	0
16:30	0	0	0	0	0	0	0	0	0	0	0	0	0	0	0	0	0	0	0	0	0	0	0
16:45	0	0	0	0	0	0	0	0	0	0	0	0	0	0	0	0	0	0	0	0	0	0	0
Total	0	0	0	0	0	0	0	0	0	0	0	0	0	0	0	0	0	0	0	0	0	0	0
17:00	0	0	0	0	0	0	0	0	0	0	0	0	0	0	0	0	0	0	0	0	0	0	0
17:15	0	0	0	0	0	0	0	0	0	0	0	0	0	0	0	0	0	0	0	0	0	0	0
17:30	0	0	1	0	1	0	0	0	0	0	0	0	0	0	0	0	0	0	0	0	0	1	0
17:45	0	0	0	0	0	0	0	0	0	0	0	0	0	0	0	0	0	0	0	0	0	0	0
Total	0	0	1	0	1	0	0	0	0	0	0	0	0	0	0	0	0	0	0	0	0	1	0
Grand Total	0	0	1	0	1	0	0	0	0	0	0	0	0	0	0	0	0	0	0	0	0	1	0
Apprch %	0.0%	0.0%	100.0%			0.0%	0.0%	0.0%			0.0%	0.0%	0.0%			0.0%	0.0%	0.0%					
Total %	0.0%	0.0%	100.0%		100.0%	0.0%	0.0%	0.0%		0.0%	0.0%	0.0%		0.0%	0.0%	0.0%	0.0%	0.0%			0.0%	100.0%	

AM PEAK HOUR	Mountain House Pkwy Southbound					I-580 WB Ramps Westbound					Mountain House Pkwy Northbound					I-580 WB Ramps Eastbound					Total	
START TIME	LEFT	THRU	RIGHT		APP.TOTAL	LEFT	THRU	RIGHT		APP.TOTAL	LEFT	THRU	RIGHT		APP.TOTAL	LEFT	THRU	RIGHT		APP.TOTAL	Total	
Peak Hour Analysis From 07:00 to 08:00																						
Peak Hour For Entire Intersection Begins at 07:00																						
07:00	0	0	0		0	0	0	0		0	0	0	0		0	0	0	0		0	0	
07:15	0	0	0		0	0	0	0		0	0	0	0		0	0	0	0		0	0	
07:30	0	0	0		0	0	0	0		0	0	0	0		0	0	0	0		0	0	
07:45	0	0	0		0	0	0	0		0	0	0	0		0	0	0	0		0	0	
Total Volume	0	0	0		0	0	0	0		0	0	0	0		0	0	0	0		0	0	
% App Total	0.0%	0.0%	0.0%			0.0%	0.0%	0.0%			0.0%	0.0%	0.0%			0.0%	0.0%	0.0%				
PHF	.000	.000	.000		.000	.000	.000	.000		.000	.000	.000	.000		.000	.000	.000	.000		.000	.000	

PM PEAK HOUR	Mountain House Pkwy Southbound					I-580 WB Ramps Westbound					Mountain House Pkwy Northbound					I-580 WB Ramps Eastbound					Total	
START TIME	LEFT	THRU	RIGHT		APP.TOTAL	LEFT	THRU	RIGHT		APP.TOTAL	LEFT	THRU	RIGHT		APP.TOTAL	LEFT	THRU	RIGHT		APP.TOTAL	Total	
Peak Hour Analysis From 16:30 to 17:30																						
Peak Hour For Entire Intersection Begins at 16:30																						
16:30	0	0	0		0	0	0	0		0	0	0	0		0	0	0	0		0	0	
16:45	0	0	0		0	0	0	0		0	0	0	0		0	0	0	0		0	0	
17:00	0	0	0		0	0	0	0		0	0	0	0		0	0	0	0		0	0	
17:15	0	0	0		0	0	0	0		0	0	0	0		0	0	0	0		0	0	
Total Volume	0	0	0		0	0	0	0		0	0	0	0		0	0	0	0		0	0	
% App Total	0.0%	0.0%	0.0%			0.0%	0.0%	0.0%			0.0%	0.0%	0.0%			0.0%	0.0%	0.0%				
PHF	.000	.000	.000		.000	.000	.000	.000		.000	.000	.000	.000		.000	.000	.000	.000		.000	.000	

ALL TRAFFIC DATA

City of Tracy
 All Vehicles on Unshifted
 Buses on Bank 1
 FHWA Class 5 and above on Bank 2

(916) 771-8700
orders@atdtraffic.com

File Name : 13-7532-014 Mountain House Pkwy-I-580 WB Ramps.ppd
 Date : 9/24/2013

ank 2 Count = FHWA Class 5 and above

START TIME	Mountain House Pkwy Southbound					I-580 WB Ramps Westbound					Mountain House Pkwy Northbound					I-580 WB Ramps Eastbound					Total	Ped Total
	LEFT	THRU	RIGHT	PEDS	APP.TOTAL	LEFT	THRU	RIGHT	PEDS	APP.TOTAL	LEFT	THRU	RIGHT	PEDS	APP.TOTAL	LEFT	THRU	RIGHT	PEDS	APP.TOTAL		
07:00	0	4	8	0	12	0	0	9	0	9	0	5	0	0	5	0	0	0	0	0	26	0
07:15	0	9	7	0	16	1	0	21	0	22	0	4	0	0	4	0	0	0	0	0	42	0
07:30	0	7	8	0	15	0	0	6	0	6	0	8	0	0	8	0	0	0	0	0	29	0
07:45	0	17	7	0	24	1	0	5	0	6	0	8	0	0	8	0	0	0	0	0	38	0
Total	0	37	30	0	67	2	0	41	0	43	0	25	0	0	25	0	0	0	0	0	135	0
08:00	0	11	6	0	17	0	1	9	0	10	0	8	0	0	8	0	0	0	0	0	35	0
08:15	0	9	13	0	22	0	0	16	0	16	0	6	0	0	6	0	0	0	0	0	44	0
08:30	0	18	11	0	29	0	0	8	0	8	0	15	0	0	15	0	0	0	0	0	52	0
08:45	0	13	10	0	23	0	0	12	0	12	0	10	0	0	10	0	0	0	0	0	45	0
Total	0	51	40	0	91	0	1	45	0	46	0	39	0	0	39	0	0	0	0	0	176	0
16:00	0	9	7	0	16	1	0	2	0	3	0	8	0	0	8	0	0	0	0	0	27	0
16:15	0	5	4	0	9	0	0	4	0	4	0	6	0	0	6	0	0	0	0	0	19	0
16:30	0	6	2	0	8	1	0	7	0	8	0	4	0	0	4	0	0	0	0	0	20	0
16:45	0	7	4	0	11	1	1	6	0	8	0	4	0	0	4	0	0	0	0	0	23	0
Total	0	27	17	0	44	3	1	19	0	23	0	22	0	0	22	0	0	0	0	0	89	0
17:00	0	4	8	0	12	0	0	4	0	4	0	8	0	0	8	0	0	0	0	0	24	0
17:15	0	2	5	0	7	1	1	1	0	3	0	9	0	0	9	0	0	0	0	0	19	0
17:30	0	4	6	0	10	1	1	7	0	9	0	2	0	0	2	0	0	0	0	0	21	0
17:45	0	7	5	0	12	1	0	5	0	6	0	8	0	0	8	0	0	0	0	0	26	0
Total	0	17	24	0	41	3	2	17	0	22	0	27	0	0	27	0	0	0	0	0	90	0
Grand Total	0	132	111	0	243	8	4	122	0	134	0	113	0	0	113	0	0	0	0	0	490	0
Apprch %	0.0%	54.3%	45.7%			6.0%	3.0%	91.0%			0.0%	100.0%	0.0%			0.0%	0.0%	0.0%				
Total %	0.0%	26.9%	22.7%		49.6%	1.6%	0.8%	24.9%		27.3%	0.0%	23.1%	0.0%		23.1%	0.0%	0.0%	0.0%		0.0%	100.0%	

AM PEAK HOUR	Mountain House Pkwy Southbound					I-580 WB Ramps Westbound					Mountain House Pkwy Northbound					I-580 WB Ramps Eastbound					Total
START TIME	LEFT	THRU	RIGHT		APP.TOTAL	LEFT	THRU	RIGHT		APP.TOTAL	LEFT	THRU	RIGHT		APP.TOTAL	LEFT	THRU	RIGHT		APP.TOTAL	Total
Peak Hour Analysis From 07:00 to 08:00																					
Peak Hour For Entire Intersection Begins at 07:00																					
07:00	0	4	8		12	0	0	9		9	0	5	0		5	0	0	0		0	26
07:15	0	9	7		16	1	0	21		22	0	4	0		4	0	0	0		0	42
07:30	0	7	8		15	0	0	6		6	0	8	0		8	0	0	0		0	29
07:45	0	17	7		24	1	0	5		6	0	8	0		8	0	0	0		0	38
Total Volume	0	37	30		67	2	0	41		43	0	25	0		25	0	0	0		0	135
% App Total	0.0%	55.2%	44.8%			4.7%	0.0%	95.3%			0.0%	100.0%	0.0%			0.0%	0.0%	0.0%			
PHF	.000	.544	.938		.698	.500	.000	.488		.489	.000	.781	.000		.781	.000	.000	.000		.000	.804

PM PEAK HOUR	Mountain House Pkwy Southbound					I-580 WB Ramps Westbound					Mountain House Pkwy Northbound					I-580 WB Ramps Eastbound					Total
START TIME	LEFT	THRU	RIGHT		APP.TOTAL	LEFT	THRU	RIGHT		APP.TOTAL	LEFT	THRU	RIGHT		APP.TOTAL	LEFT	THRU	RIGHT		APP.TOTAL	Total
Peak Hour Analysis From 16:30 to 17:30																					
Peak Hour For Entire Intersection Begins at 16:30																					
16:30	0	6	2		8	1	0	7		8	0	4	0		4	0	0	0		0	20
16:45	0	7	4		11	1	1	6		8	0	4	0		4	0	0	0		0	23
17:00	0	4	8		12	0	0	4		4	0	8	0		8	0	0	0		0	24
17:15	0	2	5		7	1	1	1		3	0	9	0		9	0	0	0		0	19
Total Volume	0	19	19		38	3	2	18		23	0	25	0		25	0	0	0		0	86
% App Total	0.0%	50.0%	50.0%			13.0%	8.7%	78.3%			0.0%	100.0%	0.0%			0.0%	0.0%	0.0%			
PHF	.000	.679	.594		.792	.750	.500	.643		.719	.000	.694	.000		.694	.000	.000	.000		.000	.896

LOCATION: W 11th St -- Corral Hollow Rd
CITY/STATE: Tracy, CA

QC JOB #: 12425013
DATE: Thu, Feb 20 2014

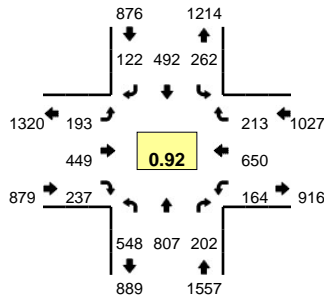

Peak-Hour: 7:30 AM -- 8:30 AM
Peak 15-Min: 7:45 AM -- 8:00 AM

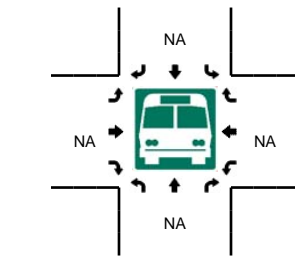
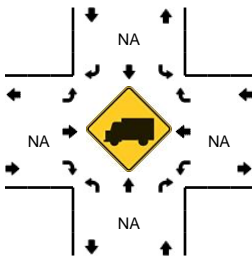
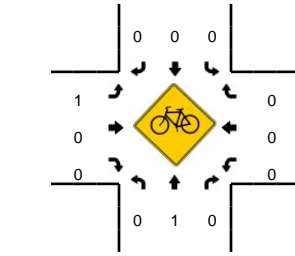
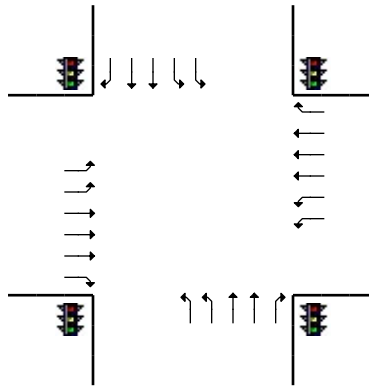
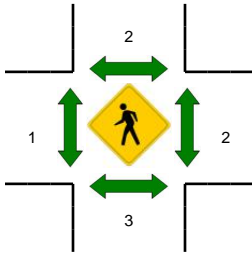
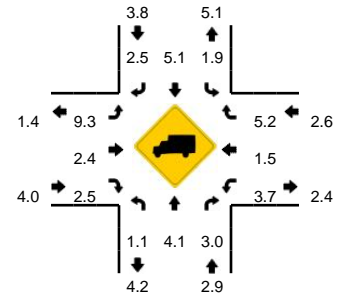

15-Min Count Period Beginning At	W 11th St (Northbound)				W 11th St (Southbound)				Corral Hollow Rd (Eastbound)				Corral Hollow Rd (Westbound)				Total	Hourly Totals
	Left	Thru	Right	U	Left	Thru	Right	U	Left	Thru	Right	U	Left	Thru	Right	U		
7:00 AM	113	115	16	0	27	53	24	1	26	32	26	0	21	115	23	1	593	
7:15 AM	117	154	26	1	32	63	32	0	36	68	18	0	12	121	20	1	701	
7:30 AM	115	184	49	0	60	102	36	0	64	132	39	0	30	133	46	1	991	
7:45 AM	130	220	53	0	85	167	30	0	38	125	68	0	45	163	53	1	1178	3463
8:00 AM	147	180	44	0	55	138	27	1	52	100	64	0	50	180	60	1	1099	3969
8:15 AM	156	223	56	0	61	85	29	0	39	92	66	0	35	174	54	1	1071	4339
8:30 AM	90	171	16	0	37	73	16	0	29	95	38	0	32	127	57	2	783	4131
8:45 AM	102	130	18	1	47	64	11	0	28	65	23	0	28	128	44	2	691	3644
Peak 15-Min Flowrates	Northbound				Southbound				Eastbound				Westbound				Total	
	Left	Thru	Right	U	Left	Thru	Right	U	Left	Thru	Right	U	Left	Thru	Right	U		
All Vehicles	520	880	212	0	340	668	120	0	152	500	272	0	180	652	212	4	4712	
Heavy Trucks	12	40	8		8	32	4		4	4	8		0	12	12		144	
Pedestrians		4				0				0				0			4	
Bicycles	0	0	0		0	0	0		0	0	0		0	0	0		0	
Railroad																		
Stopped Buses																		

Comments:

LOCATION: W 11th St -- Corral Hollow Rd
CITY/STATE: Tracy, CA

QC JOB #: 12425014
DATE: Thu, Feb 20 2014

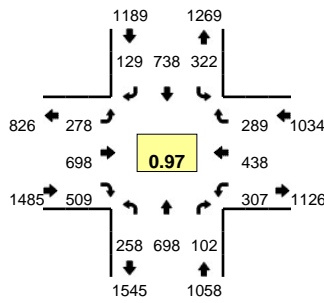

Peak-Hour: 5:00 PM -- 6:00 PM
Peak 15-Min: 5:00 PM -- 5:15 PM

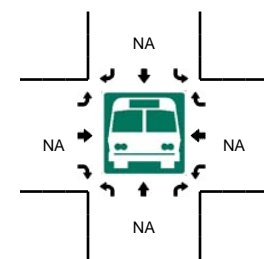
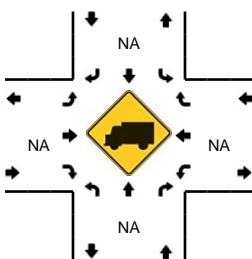
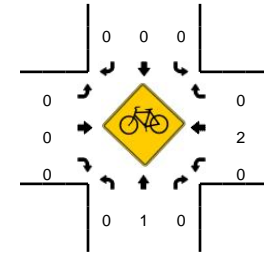
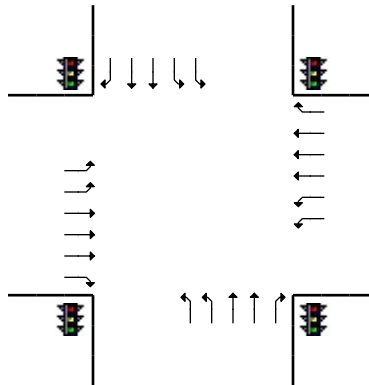
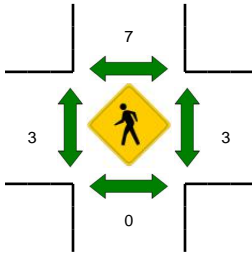
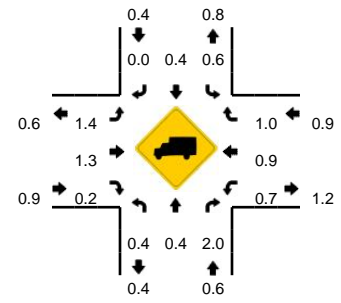

15-Min Count Period Beginning At	W 11th St (Northbound)				W 11th St (Southbound)				Corral Hollow Rd (Eastbound)				Corral Hollow Rd (Westbound)				Total	Hourly Totals	
	Left	Thru	Right	U	Left	Thru	Right	U	Left	Thru	Right	U	Left	Thru	Right	U			
4:00 PM	63	148	36	0	95	172	33	1	63	176	96	1	70	122	68	3	1147		
4:15 PM	60	202	32	1	86	172	19	2	66	145	100	0	69	94	78	2	1128		
4:30 PM	67	165	30	0	88	162	28	1	53	182	90	0	61	100	68	3	1098		
4:45 PM	51	185	19	0	96	168	27	1	50	172	97	0	49	97	60	2	1074	4447	
5:00 PM	58	176	31	0	79	194	42	0	66	180	118	0	72	121	84	3	1224	4524	
5:15 PM	59	187	19	1	80	183	34	2	67	164	134	0	74	118	82	2	1206	4602	
5:30 PM	68	171	29	0	78	189	29	1	59	181	148	0	96	96	59	3	1207	4711	
5:45 PM	72	164	23	0	79	172	24	3	84	173	109	2	55	103	64	2	1129	4766	
Peak 15-Min Flowrates	Northbound				Southbound				Eastbound				Westbound				Total		
All Vehicles	232	704	124	0	316	776	168	0	264	720	472	0	288	484	336	12	4896		
Heavy Trucks	0	0	0		0	4	0		4	4	0		0	4	4		20		
Pedestrians		0				12				8				0			20		
Bicycles	0	0	0		0	0	0		0	0	0		0	2	0		2		
Railroad																			
Stopped Buses																			

Comments:

LOCATION: N Tracy Blvd -- Central Ave
CITY/STATE: Tracy, CA

QC JOB #: 12425007
DATE: Thu, Feb 20 2014

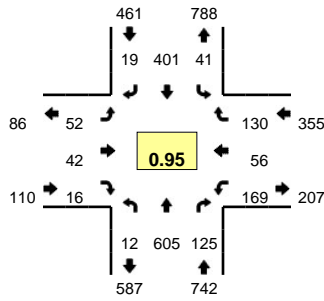

Peak-Hour: 7:30 AM -- 8:30 AM
Peak 15-Min: 7:45 AM -- 8:00 AM

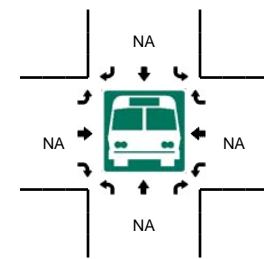
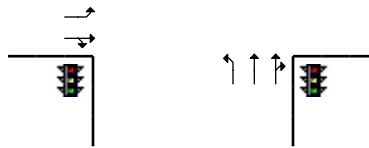
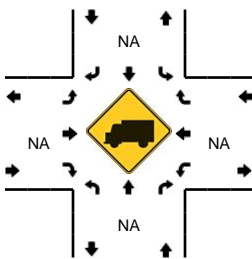
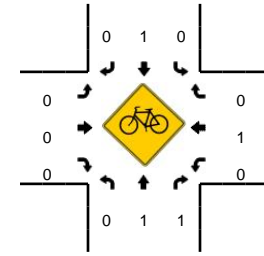
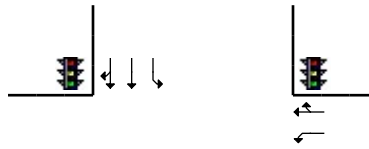
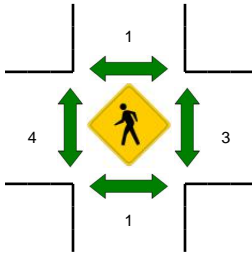
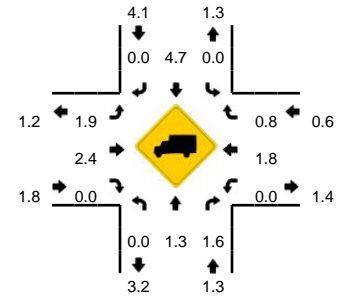

15-Min Count Period Beginning At	N Tracy Blvd (Northbound)				N Tracy Blvd (Southbound)				Central Ave (Eastbound)				Central Ave (Westbound)				Total	Hourly Totals
	Left	Thru	Right	U	Left	Thru	Right	U	Left	Thru	Right	U	Left	Thru	Right	U		
7:00 AM	3	82	13	0	5	61	2	0	6	4	4	0	15	6	11	0	212	
7:15 AM	1	101	31	0	6	53	1	0	3	4	3	0	27	7	15	0	252	
7:30 AM	2	187	35	0	5	71	5	0	12	8	5	0	37	15	24	0	406	
7:45 AM	3	160	35	0	8	118	4	0	15	10	4	0	49	12	23	0	441	1311
8:00 AM	4	128	25	0	14	125	0	1	17	16	1	0	43	10	41	0	425	1524
8:15 AM	2	130	30	1	13	87	10	0	8	8	6	0	40	19	42	0	396	1668
8:30 AM	5	97	14	0	6	90	6	0	2	5	1	0	30	3	13	0	272	1534
8:45 AM	2	98	14	2	5	90	4	0	3	1	4	0	19	7	14	0	263	1356
Peak 15-Min Flowrates	Northbound				Southbound				Eastbound				Westbound				Total	
All Vehicles	12	640	140	0	32	472	16	0	60	40	16	0	196	48	92	0	1764	
Heavy Trucks	0	4	0		0	16	0		4	0	0		0	0	0		24	
Pedestrians		0				0				0				0				0
Bicycles	0	1	1		0	1	0		0	0	0		0	0	0			3
Railroad																		
Stopped Buses																		

Comments:

LOCATION: N Tracy Blvd -- Central Ave
CITY/STATE: Tracy, CA

QC JOB #: 12425008
DATE: Thu, Feb 20 2014

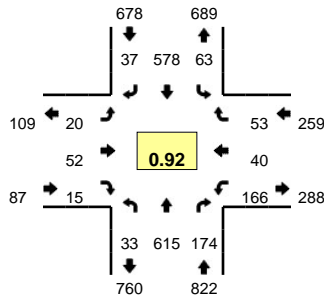

Peak-Hour: 5:00 PM -- 6:00 PM
Peak 15-Min: 5:15 PM -- 5:30 PM

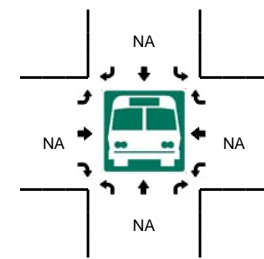
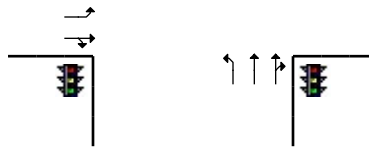
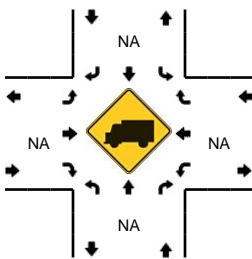
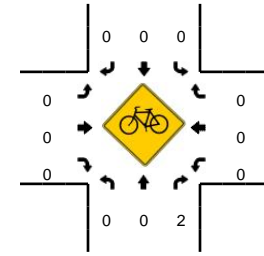
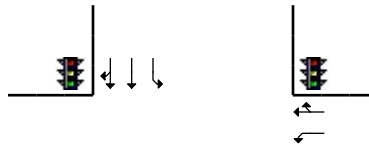
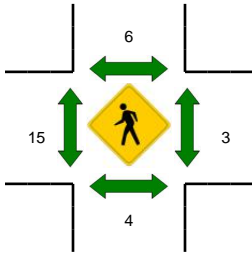
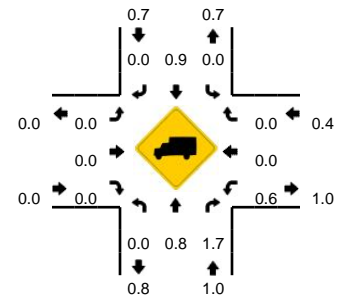

15-Min Count Period Beginning At	N Tracy Blvd (Northbound)				N Tracy Blvd (Southbound)				Central Ave (Eastbound)				Central Ave (Westbound)				Total	Hourly Totals
	Left	Thru	Right	U	Left	Thru	Right	U	Left	Thru	Right	U	Left	Thru	Right	U		
4:00 PM	5	131	44	0	26	142	9	0	5	8	2	0	41	4	18	0	435	
4:15 PM	2	136	52	0	19	127	7	0	3	8	6	0	37	9	21	0	427	
4:30 PM	3	137	34	0	13	140	10	0	4	15	5	0	26	11	7	0	405	
4:45 PM	5	131	37	0	13	143	10	0	7	15	5	0	42	8	14	0	430	1697
5:00 PM	8	161	44	1	6	141	5	0	3	9	6	0	33	13	17	0	447	1709
5:15 PM	9	179	42	0	14	158	6	0	8	8	5	0	52	7	13	0	501	1783
5:30 PM	9	125	45	0	11	120	12	1	1	15	3	0	37	9	10	0	398	1776
5:45 PM	6	150	43	0	31	159	14	0	8	20	1	0	44	11	13	0	500	1846

Peak 15-Min Flowrates	Northbound				Southbound				Eastbound				Westbound				Total
	Left	Thru	Right	U	Left	Thru	Right	U	Left	Thru	Right	U	Left	Thru	Right	U	
All Vehicles	36	716	168	0	56	632	24	0	32	32	20	0	208	28	52	0	2004
Heavy Trucks	0	8	0		0	4	0		0	0	0		0	0	0		12
Pedestrians		0				12				20				4			36
Bicycles	0	0	1		0	0	0		0	0	0		0	0	0		1
Railroad																	
Stopped Buses																	

Comments:

LOCATION: N Tracy Blvd -- 11th St
CITY/STATE: Tracy, CA

QC JOB #: 12425009
DATE: Thu, Feb 20 2014

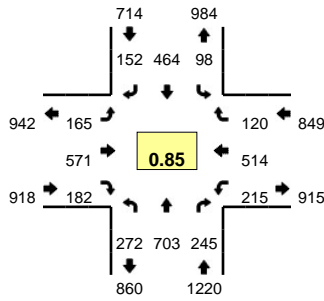

Peak-Hour: 7:30 AM -- 8:30 AM
Peak 15-Min: 7:45 AM -- 8:00 AM

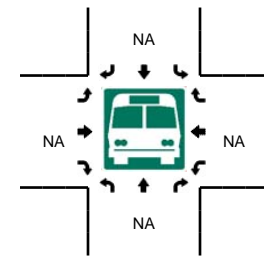
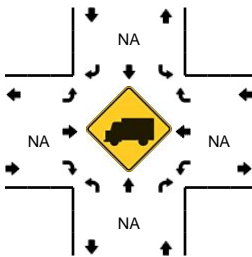
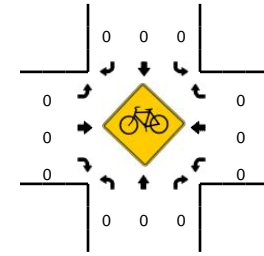
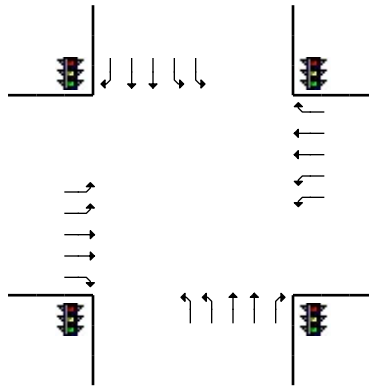
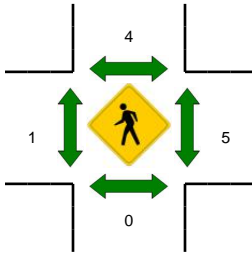
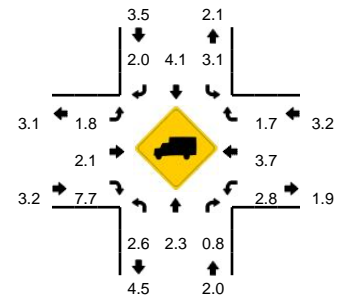

15-Min Count Period Beginning At	N Tracy Blvd (Northbound)				N Tracy Blvd (Southbound)				11th St (Eastbound)				11th St (Westbound)				Total	Hourly Totals
	Left	Thru	Right	U	Left	Thru	Right	U	Left	Thru	Right	U	Left	Thru	Right	U		
7:00 AM	40	71	5	0	8	40	17	0	20	49	13	1	9	66	11	0	350	
7:15 AM	30	93	38	0	12	36	17	0	24	73	22	0	23	61	13	0	442	
7:30 AM	50	150	89	0	20	59	27	2	37	151	42	1	45	111	14	0	798	
7:45 AM	57	216	70	1	22	132	41	0	41	174	56	1	71	166	42	1	1091	2681
8:00 AM	79	159	48	1	33	160	45	0	41	148	39	2	66	143	35	0	999	3330
8:15 AM	84	178	38	0	21	113	39	0	40	98	45	2	30	94	29	2	813	3701
8:30 AM	63	134	28	0	20	75	36	0	38	100	46	2	23	98	29	2	694	3597
8:45 AM	68	121	30	1	21	73	30	1	38	93	50	1	12	90	24	1	654	3160
Peak 15-Min Flowrates	Northbound				Southbound				Eastbound				Westbound				Total	
	Left	Thru	Right	U	Left	Thru	Right	U	Left	Thru	Right	U	Left	Thru	Right	U		
All Vehicles	228	864	280	4	88	528	164	0	164	696	224	4	284	664	168	4	4364	
Heavy Trucks	0	24	0		8	28	4		8	16	12		8	16	0		124	
Pedestrians		0				0				4				20			24	
Bicycles	0	0	0		0	0	0		0	0	0		0	0	0		0	
Railroad																		
Stopped Buses																		

Comments:

LOCATION: N Tracy Blvd -- 11th St
CITY/STATE: Tracy, CA

QC JOB #: 12425010
DATE: Thu, Feb 20 2014

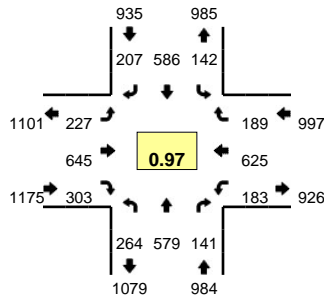

Peak-Hour: 4:30 PM -- 5:30 PM
Peak 15-Min: 5:15 PM -- 5:30 PM

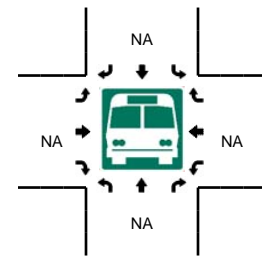
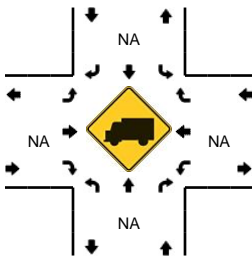
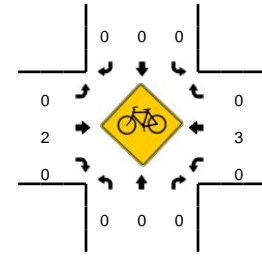
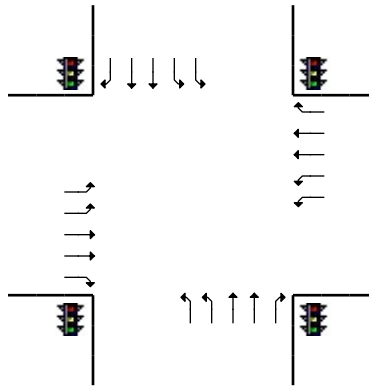
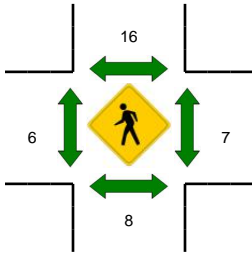
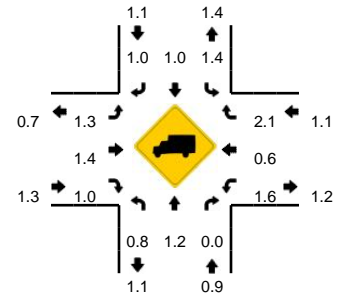

15-Min Count Period Beginning At	N Tracy Blvd (Northbound)				N Tracy Blvd (Southbound)				11th St (Eastbound)				11th St (Westbound)				Total	Hourly Totals
	Left	Thru	Right	U	Left	Thru	Right	U	Left	Thru	Right	U	Left	Thru	Right	U		
4:00 PM	55	131	40	1	39	140	59	2	45	169	74	3	56	154	42	3	1013	
4:15 PM	64	126	25	0	26	107	49	2	45	152	64	4	47	144	50	0	905	
4:30 PM	55	151	33	3	53	147	43	2	55	168	80	2	41	155	42	2	1032	
4:45 PM	57	127	40	3	30	146	42	2	52	147	67	6	46	149	45	1	960	3910
5:00 PM	69	154	38	2	24	145	57	2	46	147	76	2	48	176	59	1	1046	3943
5:15 PM	72	147	30	3	29	148	65	0	58	183	80	6	44	145	43	0	1053	4091
5:30 PM	55	114	37	4	56	111	38	1	40	174	79	11	56	138	39	0	953	4012
5:45 PM	74	114	20	0	27	157	34	2	38	131	86	6	53	142	44	3	931	3983
Peak 15-Min Flowrates	Northbound				Southbound				Eastbound				Westbound				Total	
	Left	Thru	Right	U	Left	Thru	Right	U	Left	Thru	Right	U	Left	Thru	Right	U		
All Vehicles	288	588	120	12	116	592	260	0	232	732	320	24	176	580	172	0	4212	
Heavy Trucks	0	0	0		0	4	4		8	16	0		0	4	8		44	
Pedestrians		0				12				16				16			44	
Bicycles	0	0	0		0	0	0		0	0	0		0	1	0		1	
Railroad																		
Stopped Buses																		

Comments:

LOCATION: S Chrisman Rd -- W Linne Rd
CITY/STATE: Tracy, CA

QC JOB #: 12425005
DATE: Thu, Feb 20 2014

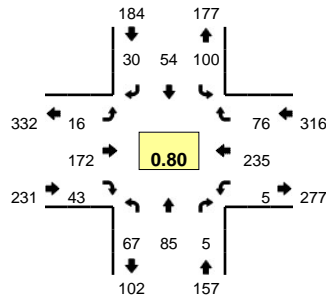

Peak-Hour: 7:15 AM -- 8:15 AM
Peak 15-Min: 7:45 AM -- 8:00 AM

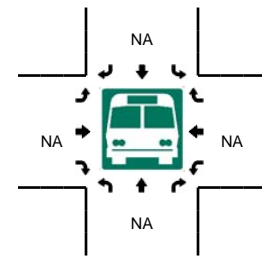
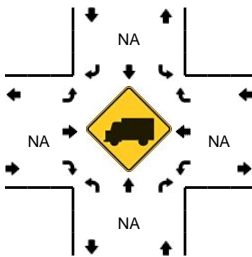
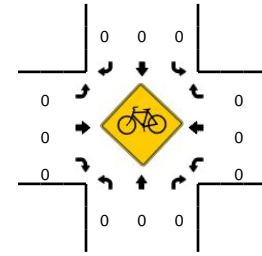
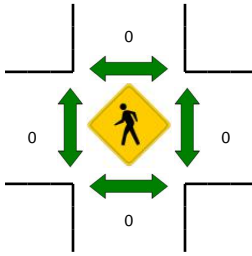
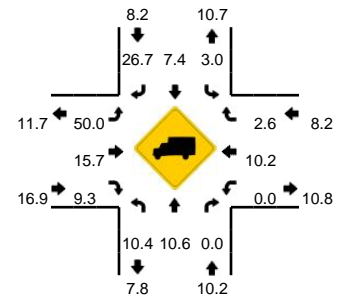

15-Min Count Period Beginning At	S Chrisman Rd (Northbound)				S Chrisman Rd (Southbound)				W Linne Rd (Eastbound)				W Linne Rd (Westbound)				Total	Hourly Totals
	Left	Thru	Right	U	Left	Thru	Right	U	Left	Thru	Right	U	Left	Thru	Right	U		
7:00 AM	9	10	0	0	6	7	6	0	1	21	4	0	3	33	11	0	111	
7:15 AM	11	18	1	0	13	12	8	0	5	25	8	0	0	29	10	0	140	
7:30 AM	10	21	1	0	22	13	5	0	3	34	8	0	1	58	18	0	194	
7:45 AM	29	25	1	0	33	16	7	0	5	56	15	0	3	74	14	0	278	723
8:00 AM	17	21	2	0	32	13	10	0	3	57	12	0	1	74	34	0	276	888
8:15 AM	6	12	2	0	4	8	8	0	1	22	6	0	1	28	9	0	107	855
8:30 AM	7	17	1	0	14	12	6	0	5	15	7	0	1	24	7	0	116	777
8:45 AM	7	19	1	0	6	13	5	0	3	19	5	0	0	16	11	0	105	604
Peak 15-Min Flowrates	Northbound				Southbound				Eastbound				Westbound				Total	
	Left	Thru	Right	U	Left	Thru	Right	U	Left	Thru	Right	U	Left	Thru	Right	U		
All Vehicles	116	100	4	0	132	64	28	0	20	224	60	0	12	296	56	0	1112	
Heavy Trucks	0	4	0	0	12	0	8	0	8	40	4	0	0	20	0	0	96	
Pedestrians	0	0	0	0	0	0	0	0	0	0	0	0	0	0	0	0	0	
Bicycles	0	0	0	0	0	0	0	0	0	0	0	0	0	0	0	0	0	
Railroad																		
Stopped Buses																		

Comments:

LOCATION: S Chrisman Rd -- W Linne Rd
CITY/STATE: Tracy, CA

QC JOB #: 12425006
DATE: Thu, Feb 20 2014

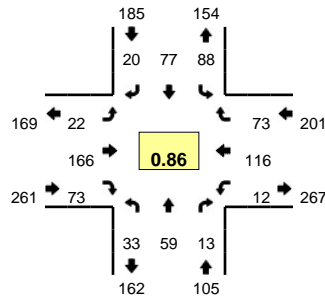

Peak-Hour: 4:00 PM -- 5:00 PM
Peak 15-Min: 4:30 PM -- 4:45 PM

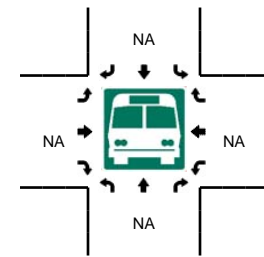
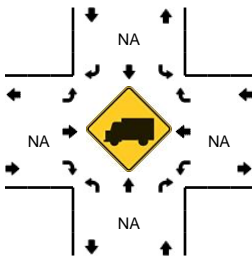
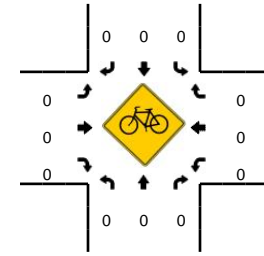
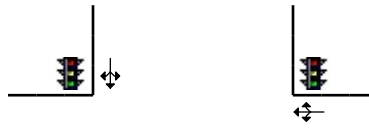
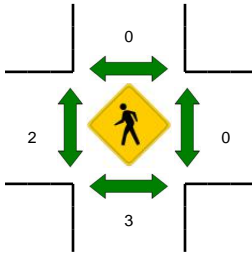
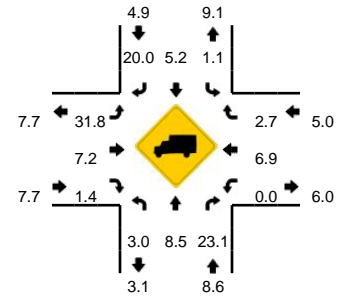

15-Min Count Period Beginning At	S Chrisman Rd (Northbound)				S Chrisman Rd (Southbound)				W Linne Rd (Eastbound)				W Linne Rd (Westbound)				Total	Hourly Totals
	Left	Thru	Right	U	Left	Thru	Right	U	Left	Thru	Right	U	Left	Thru	Right	U		
4:00 PM	7	16	7	0	18	18	4	0	6	37	15	0	6	48	20	0	202	
4:15 PM	9	11	3	0	26	21	3	0	4	26	21	0	0	20	13	0	157	
4:30 PM	10	15	2	0	26	21	6	0	7	60	11	0	5	31	25	0	219	
4:45 PM	7	17	1	0	18	17	7	0	5	43	26	0	1	17	15	0	174	752
5:00 PM	13	12	1	0	18	21	3	0	4	33	19	0	3	19	10	0	156	706
5:15 PM	9	12	5	0	21	25	1	0	3	36	16	0	0	19	11	0	158	707
5:30 PM	9	19	2	0	15	11	3	0	3	37	10	0	0	34	15	0	158	646
5:45 PM	14	24	0	0	8	21	1	0	5	20	8	0	3	19	12	0	135	607
Peak 15-Min Flowrates	Northbound				Southbound				Eastbound				Westbound				Total	
	Left	Thru	Right	U	Left	Thru	Right	U	Left	Thru	Right	U	Left	Thru	Right	U		
All Vehicles	40	60	8	0	104	84	24	0	28	240	44	0	20	124	100	0	876	
Heavy Trucks	4	4	0		0	12	4		4	4	0		0	4	4		40	
Pedestrians		8				0				4				0			12	
Bicycles	0	0	0		0	0	0		0	0	0		0	0	0		0	
Railroad																		
Stopped Buses																		

Comments:

LOCATION: S Chrisman Rd -- W 11th St
CITY/STATE: Tracy, CA

QC JOB #: 12425003
DATE: Thu, Feb 20 2014

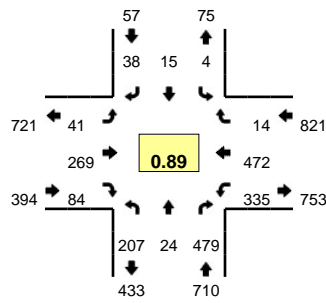

Peak-Hour: 7:15 AM -- 8:15 AM
Peak 15-Min: 7:30 AM -- 7:45 AM

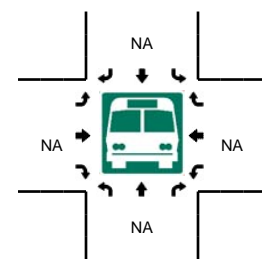
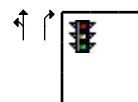
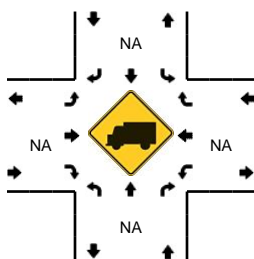
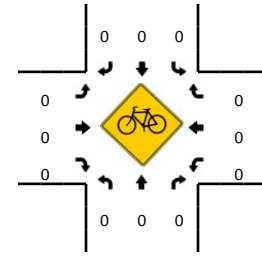
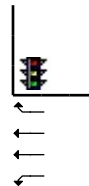
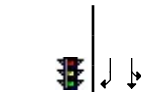
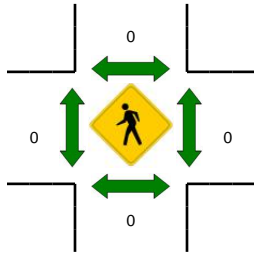
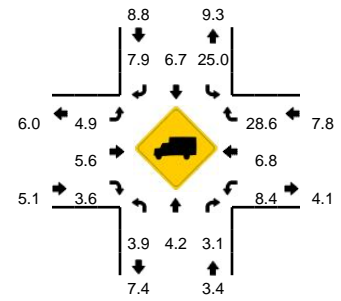

15-Min Count Period Beginning At	S Chrisman Rd (Northbound)				S Chrisman Rd (Southbound)				W 11th St (Eastbound)				W 11th St (Westbound)				Total	Hourly Totals
	Left	Thru	Right	U	Left	Thru	Right	U	Left	Thru	Right	U	Left	Thru	Right	U		
7:00 AM	12	3	98	0	1	2	5	0	2	51	11	1	51	79	1	0	317	
7:15 AM	35	0	133	0	1	0	4	0	4	55	15	1	85	96	2	0	431	
7:30 AM	79	6	137	0	1	2	10	0	6	69	18	2	99	126	4	0	559	
7:45 AM	65	7	100	0	1	8	13	0	13	76	28	0	72	150	4	1	538	1845
8:00 AM	28	11	109	0	1	5	11	0	14	69	23	1	78	100	4	0	454	1982
8:15 AM	16	3	89	0	0	4	10	0	10	66	18	0	67	99	4	0	386	1937
8:30 AM	12	4	89	0	2	4	10	0	3	58	14	0	60	89	4	0	349	1727
8:45 AM	12	1	73	0	0	1	5	0	5	54	7	0	57	96	2	0	313	1502
Peak 15-Min Flowrates	Northbound				Southbound				Eastbound				Westbound				Total	
All Vehicles	316	24	548	0	4	8	40	0	24	276	72	8	396	504	16	0	2236	
Heavy Trucks	12	0	16		0	4	0		0	12	0		24	32	4		104	
Pedestrians	0				0				0	0			0				0	
Bicycles	0	0	0		0	0	0		0	0	0		0	0	0		0	
Railroad																		
Stopped Buses																		

Comments:

LOCATION: S Chrisman Rd -- W 11th St
CITY/STATE: Tracy, CA

QC JOB #: 12425004
DATE: Thu, Feb 20 2014

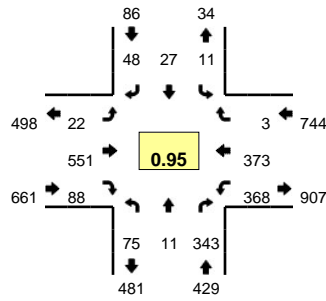

Peak-Hour: 4:30 PM -- 5:30 PM
Peak 15-Min: 5:00 PM -- 5:15 PM

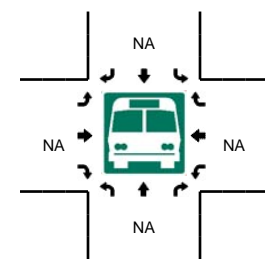
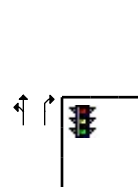
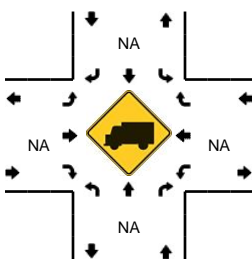
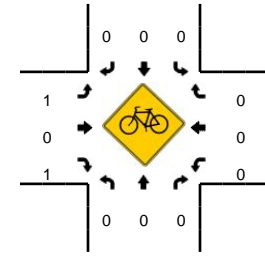
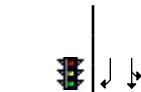
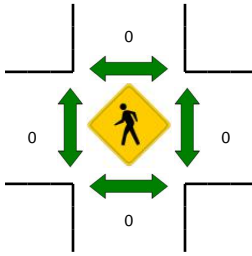
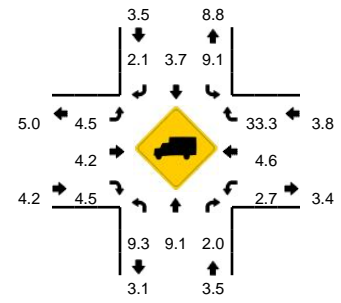

15-Min Count Period Beginning At	S Chrisman Rd (Northbound)				S Chrisman Rd (Southbound)				W 11th St (Eastbound)				W 11th St (Westbound)				Total	Hourly Totals
	Left	Thru	Right	U	Left	Thru	Right	U	Left	Thru	Right	U	Left	Thru	Right	U		
4:00 PM	24	4	94	0	2	4	8	0	9	124	24	0	77	86	2	0	458	
4:15 PM	14	1	84	0	4	3	11	0	10	118	17	1	89	72	0	1	425	
4:30 PM	21	1	105	0	6	4	18	0	4	122	27	1	69	82	1	0	461	
4:45 PM	18	3	91	0	2	3	6	0	6	114	16	0	96	109	0	0	464	1808
5:00 PM	22	3	71	0	3	17	19	0	4	165	24	0	89	85	1	0	503	1853
5:15 PM	14	4	76	0	0	3	5	0	6	150	21	1	112	97	1	2	492	1920
5:30 PM	12	0	80	0	2	3	5	0	4	141	11	0	105	90	3	2	458	1917
5:45 PM	12	9	56	0	2	4	4	0	13	90	20	1	86	74	0	2	373	1826
Peak 15-Min Flowrates	Northbound				Southbound				Eastbound				Westbound				Total	
	Left	Thru	Right	U	Left	Thru	Right	U	Left	Thru	Right	U	Left	Thru	Right	U		
All Vehicles	88	12	284	0	12	68	76	0	16	660	96	0	356	340	4	0	2012	
Heavy Trucks	8	0	4		4	0	0		0	28	0		12	20	0		76	
Pedestrians	0	0	0		0	0	0		0	0	0		0	0	0		0	
Bicycles	0	0	0		0	0	0		0	0	0		0	0	0		0	
Railroad																		
Stopped Buses																		

Comments:

LOCATION: S MacArthur Dr -- W Linne Rd
CITY/STATE: Tracy, CA

QC JOB #: 12425001
DATE: Thu, Feb 20 2014

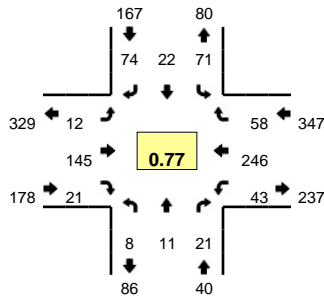

Peak-Hour: 7:30 AM -- 8:30 AM
Peak 15-Min: 7:45 AM -- 8:00 AM

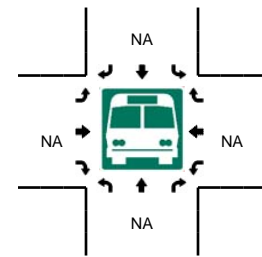
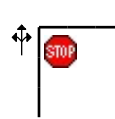
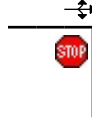
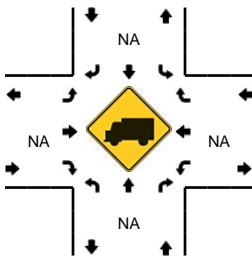
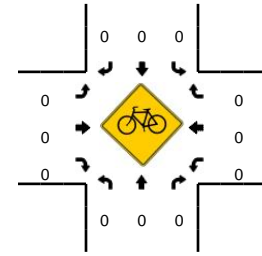
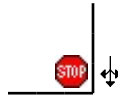
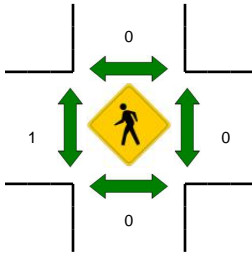
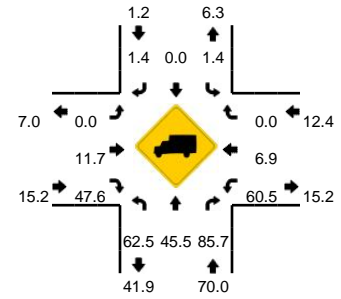

15-Min Count Period Beginning At	S MacArthur Dr (Northbound)				S MacArthur Dr (Southbound)				W Linne Rd (Eastbound)				W Linne Rd (Westbound)				Total	Hourly Totals
	Left	Thru	Right	U	Left	Thru	Right	U	Left	Thru	Right	U	Left	Thru	Right	U		
7:00 AM	4	0	7	0	11	3	23	0	5	16	1	0	6	23	18	0	117	
7:15 AM	1	0	7	0	12	2	19	0	5	23	2	0	9	27	9	0	116	
7:30 AM	1	3	4	0	13	8	23	0	2	28	1	0	14	48	7	0	152	
7:45 AM	1	1	3	0	24	8	22	0	3	51	11	0	9	80	24	0	237	622
8:00 AM	1	1	4	0	24	4	16	0	2	41	7	0	10	86	18	0	214	719
8:15 AM	5	6	10	0	10	2	13	0	4	25	2	1	10	32	9	0	129	732
8:30 AM	9	1	8	0	7	4	10	0	6	20	5	0	4	27	8	0	109	689
8:45 AM	3	3	5	0	6	3	7	0	4	14	3	0	4	23	10	0	85	537

Peak 15-Min Flowrates	Northbound				Southbound				Eastbound				Westbound				Total
	Left	Thru	Right	U	Left	Thru	Right	U	Left	Thru	Right	U	Left	Thru	Right	U	
All Vehicles	4	4	12	0	96	32	88	0	12	204	44	0	36	320	96	0	948
Heavy Trucks	0	4	12		0	0	4		0	16	16		8	24	0		84
Pedestrians		0				0				0				0			0
Bicycles	0	0	0		0	0	0		0	0	0		0	0	0		0
Railroad																	0
Stopped Buses																	0

Comments:

LOCATION: S MacArthur Dr -- W Linne Rd
CITY/STATE: Tracy, CA

QC JOB #: 12425002
DATE: Thu, Feb 20 2014

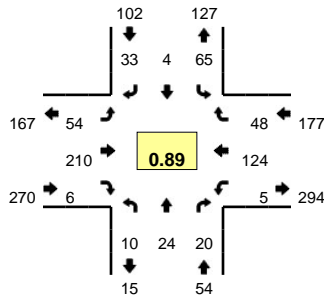

Peak-Hour: 4:30 PM -- 5:30 PM
Peak 15-Min: 4:30 PM -- 4:45 PM

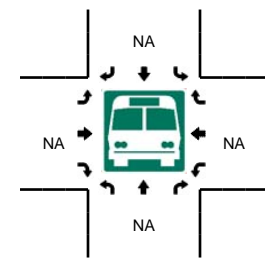
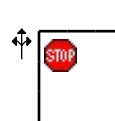
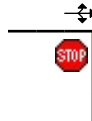
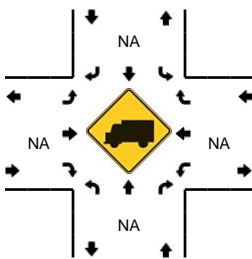
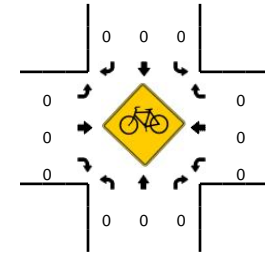
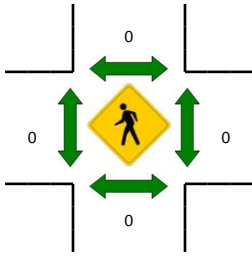
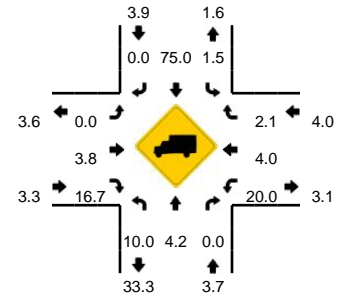

15-Min Count Period Beginning At	S MacArthur Dr (Northbound)				S MacArthur Dr (Southbound)				W Linne Rd (Eastbound)				W Linne Rd (Westbound)				Total	Hourly Totals
	Left	Thru	Right	U	Left	Thru	Right	U	Left	Thru	Right	U	Left	Thru	Right	U		
4:00 PM	1	1	1	0	9	1	2	0	10	53	2	0	3	42	18	0	143	
4:15 PM	4	7	3	0	13	4	3	0	12	47	1	0	0	21	10	0	125	
4:30 PM	3	4	3	0	20	3	6	1	12	64	3	0	2	31	18	0	170	
4:45 PM	2	2	4	0	13	1	8	0	10	63	2	0	2	29	12	0	148	586
5:00 PM	3	16	10	0	17	0	8	0	15	38	0	0	0	34	7	0	148	591
5:15 PM	2	2	3	0	14	0	11	0	17	45	1	0	1	30	11	0	137	603
5:30 PM	1	2	1	0	8	2	3	0	15	53	0	0	1	32	10	0	128	561
5:45 PM	0	2	0	0	7	1	4	0	11	32	0	0	0	25	27	0	109	522
Peak 15-Min Flowrates	Northbound				Southbound				Eastbound				Westbound				Total	
	Left	Thru	Right	U	Left	Thru	Right	U	Left	Thru	Right	U	Left	Thru	Right	U		
All Vehicles	12	16	12	0	80	12	24	4	48	256	12	0	8	124	72	0	680	
Heavy Trucks	4	4	0		0	8	0		0	4	4		4	12	4		44	
Pedestrians		0				0				0				0			0	
Bicycles	0	0	0		0	0	0		0	0	0		0	0	0		0	
Railroad																	0	
Stopped Buses																	0	

Comments:

LOCATION: Corral Hollow Rd -- Tennis Ln
CITY/STATE: Tracy, CA

QC JOB #: 12425011
DATE: Thu, Feb 20 2014

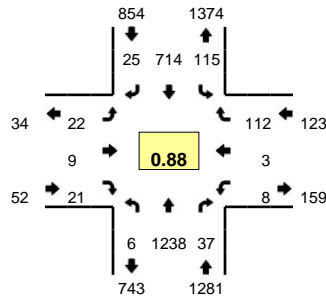

Peak-Hour: 7:30 AM -- 8:30 AM
Peak 15-Min: 8:00 AM -- 8:15 AM

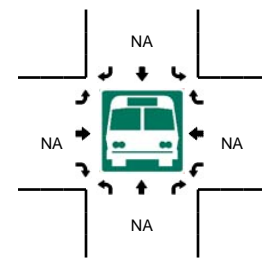
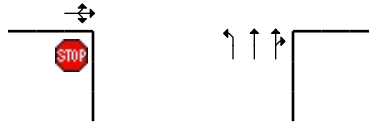
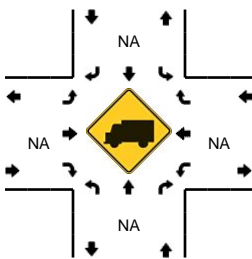
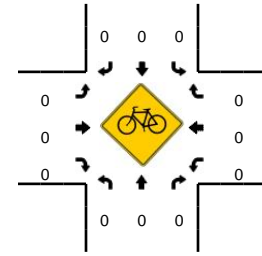
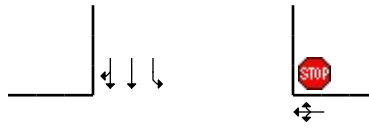
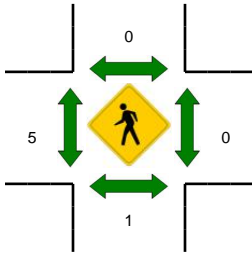
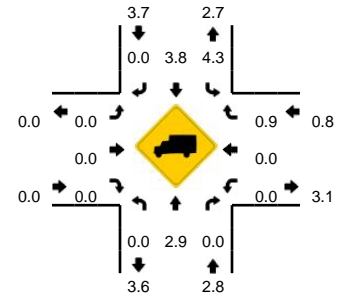

15-Min Count Period Beginning At	Corral Hollow Rd (Northbound)				Corral Hollow Rd (Southbound)				Tennis Ln (Eastbound)				Tennis Ln (Westbound)				Total	Hourly Totals
	Left	Thru	Right	U	Left	Thru	Right	U	Left	Thru	Right	U	Left	Thru	Right	U		
7:00 AM	1	191	3	0	14	89	3	0	6	1	1	0	2	2	24	0	337	
7:15 AM	2	202	1	0	7	84	0	0	10	0	1	0	1	0	28	0	336	
7:30 AM	1	250	5	0	28	117	5	0	10	0	0	0	0	0	34	0	450	
7:45 AM	1	314	20	0	42	207	8	0	5	5	3	0	4	0	37	0	646	1769
8:00 AM	0	327	11	0	29	236	8	1	3	2	15	0	2	0	25	0	659	2091
8:15 AM	4	347	1	0	14	154	4	1	4	2	3	0	2	3	16	0	555	2310
8:30 AM	5	218	1	0	11	132	5	2	6	0	1	0	1	3	18	0	403	2263
8:45 AM	2	206	0	0	7	122	4	1	8	1	2	0	0	0	14	0	367	1984
Peak 15-Min Flowrates	Northbound				Southbound				Eastbound				Westbound				Total	
	Left	Thru	Right	U	Left	Thru	Right	U	Left	Thru	Right	U	Left	Thru	Right	U		
All Vehicles	0	1308	44	0	116	944	32	4	12	8	60	0	8	0	100	0	2636	
Heavy Trucks	0	24	0		0	12	0		0	0	0		0	0	0		36	
Pedestrians		0				0				8				0			8	
Bicycles	0	0	0		0	0	0		0	0	0		0	0	0		0	
Railroad																		
Stopped Buses																		

Comments:

LOCATION: Corral Hollow Rd -- Tennis Ln
CITY/STATE: Tracy, CA

QC JOB #: 12425012
DATE: Thu, Feb 20 2014

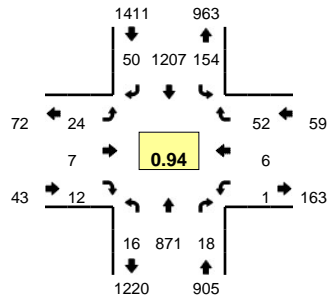

Peak-Hour: 5:00 PM -- 6:00 PM
Peak 15-Min: 5:30 PM -- 5:45 PM

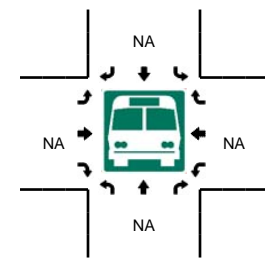
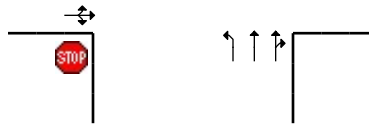
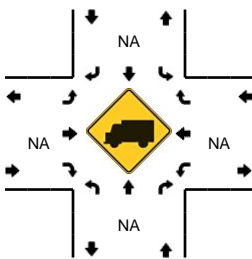
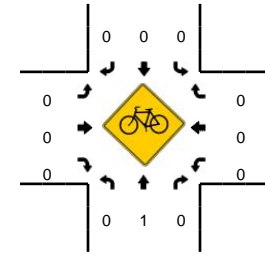
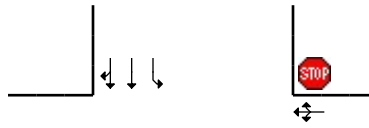
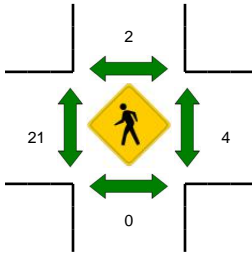
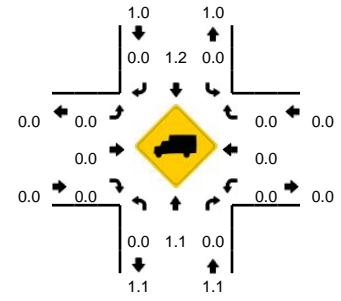

15-Min Count Period Beginning At	Corral Hollow Rd (Northbound)				Corral Hollow Rd (Southbound)				Tennis Ln (Eastbound)				Tennis Ln (Westbound)				Total	Hourly Totals
	Left	Thru	Right	U	Left	Thru	Right	U	Left	Thru	Right	U	Left	Thru	Right	U		
4:00 PM	1	173	5	0	38	302	11	1	6	1	2	0	2	1	12	0	555	
4:15 PM	4	223	5	0	32	271	12	1	7	1	3	0	0	0	12	0	571	
4:30 PM	3	226	3	0	23	267	14	2	6	2	2	0	1	2	11	0	562	
4:45 PM	2	204	2	0	29	281	13	1	3	1	4	0	4	0	16	0	560	2248
5:00 PM	6	217	6	0	38	307	8	3	7	1	3	0	1	0	9	0	606	2299
5:15 PM	4	197	1	0	37	280	10	1	3	0	2	0	0	2	9	0	546	2274
5:30 PM	1	211	5	0	38	327	23	3	5	3	4	0	0	2	18	0	640	2352
5:45 PM	5	246	6	0	25	293	9	9	9	3	3	0	0	2	16	0	626	2418
Peak 15-Min Flowrates	Northbound				Southbound				Eastbound				Westbound				Total	
All Vehicles	4	844	20	0	152	1308	92	12	20	12	16	0	0	8	72	0	2560	
Heavy Trucks	0	8	0	0	0	0	0	0	0	0	0	0	0	0	0	0	8	
Pedestrians	0	0	0	0	0	0	0	0	0	32	0	0	0	8	0	0	40	
Bicycles	0	0	0	0	0	0	0	0	0	0	0	0	0	0	0	0	0	
Railroad																		
Stopped Buses																		

Comments:

LOCATION: Mountain House Pkwy -- W Schulte Rd
CITY/STATE: Tracy, CA

QC JOB #: 12425015
DATE: Thu, Feb 20 2014

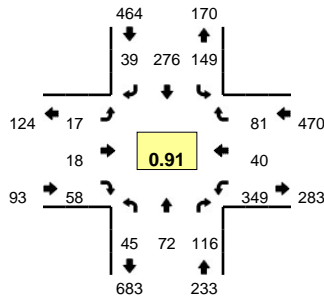

Peak-Hour: 7:00 AM -- 8:00 AM
Peak 15-Min: 7:15 AM -- 7:30 AM

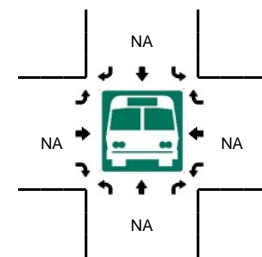
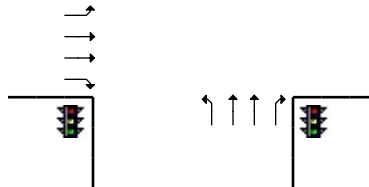
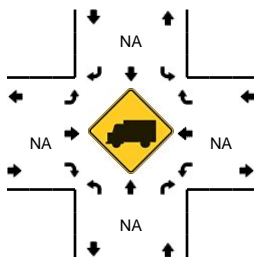
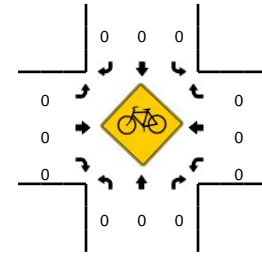
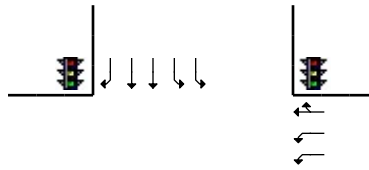
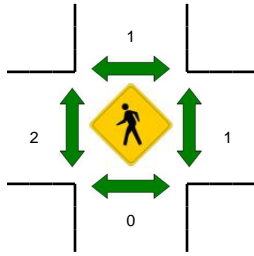
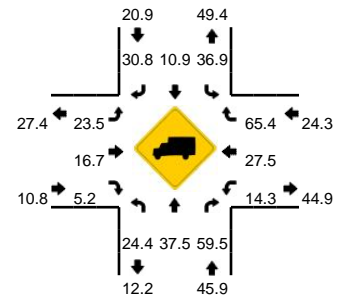

15-Min Count Period Beginning At	Mountain House Pkwy (Northbound)				Mountain House Pkwy (Southbound)				W Schulte Rd (Eastbound)				W Schulte Rd (Westbound)				Total	Hourly Totals
	Left	Thru	Right	U	Left	Thru	Right	U	Left	Thru	Right	U	Left	Thru	Right	U		
7:00 AM	10	20	18	0	34	80	2	0	2	5	20	0	112	9	25	0	337	
7:15 AM	10	14	35	0	36	88	13	0	6	2	18	0	99	8	19	0	348	
7:30 AM	10	20	28	0	35	62	8	0	6	6	7	0	90	16	20	0	308	
7:45 AM	15	18	35	0	44	46	16	0	3	5	13	0	48	7	17	0	267	1260
8:00 AM	18	14	33	0	33	30	10	0	3	4	10	0	39	6	18	0	218	1141
8:15 AM	18	18	25	0	23	28	11	0	8	6	11	0	37	6	22	0	213	1006
8:30 AM	14	10	23	0	29	25	2	0	4	3	18	0	38	9	25	0	200	898
8:45 AM	10	16	19	0	33	24	14	2	5	1	10	0	45	5	27	0	211	842
Peak 15-Min Flowrates	Northbound				Southbound				Eastbound				Westbound				Total	
All Vehicles	40	56	140	0	144	352	52	0	24	8	72	0	396	32	76	0	1392	
Heavy Trucks	4	32	96		80	40	20		8	0	0		52	8	60		400	
Pedestrians	0	0	0		0	0	0		0	0	0		0	0	0		0	
Bicycles	0	0	0		0	0	0		0	0	0		0	0	0		0	
Railroad																		
Stopped Buses																		

Comments:

LOCATION: Mountain House Pkwy -- W Schulte Rd
CITY/STATE: Tracy, CA

QC JOB #: 12425016
DATE: Thu, Feb 20 2014

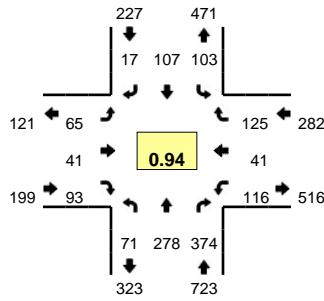

Peak-Hour: 4:30 PM -- 5:30 PM
Peak 15-Min: 5:00 PM -- 5:15 PM

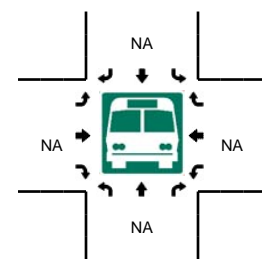
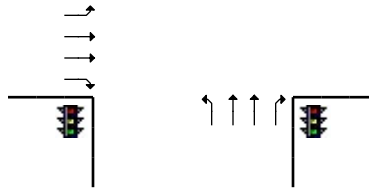
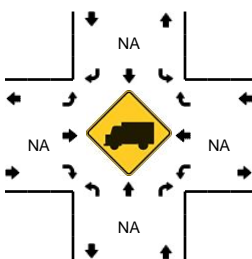
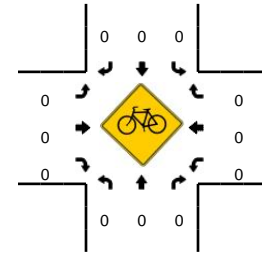
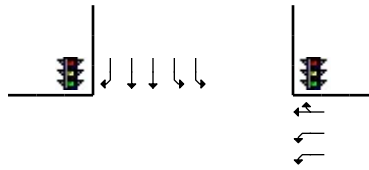
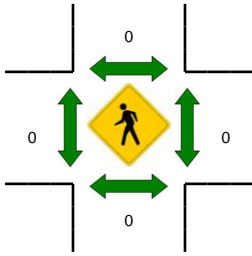
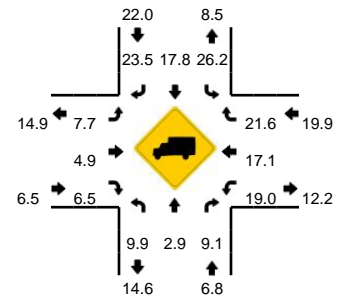

15-Min Count Period Beginning At	Mountain House Pkwy (Northbound)				Mountain House Pkwy (Southbound)				W Schulte Rd (Eastbound)				W Schulte Rd (Westbound)				Total	Hourly Totals
	Left	Thru	Right	U	Left	Thru	Right	U	Left	Thru	Right	U	Left	Thru	Right	U		
4:00 PM	14	33	59	2	12	36	3	1	3	5	13	0	27	4	20	0	232	
4:15 PM	18	64	63	3	38	27	8	2	8	7	11	0	17	9	29	0	304	
4:30 PM	14	63	91	2	25	29	6	0	16	7	20	0	42	8	34	1	358	
4:45 PM	15	71	106	4	37	26	4	0	11	7	22	0	22	11	29	0	365	1259
5:00 PM	19	71	86	1	28	29	5	1	23	12	28	0	27	15	35	0	380	1407
5:15 PM	15	73	91	1	10	23	2	2	15	15	23	0	24	7	27	0	328	1431
5:30 PM	19	63	76	0	13	24	7	2	14	7	23	0	13	7	15	0	283	1356
5:45 PM	12	69	82	0	20	17	7	1	13	9	37	0	9	8	16	0	300	1291
Peak 15-Min Flowrates	Northbound				Southbound				Eastbound				Westbound				Total	
All Vehicles	76	284	344	4	112	116	20	4	92	48	112	0	108	60	140	0	1520	
Heavy Trucks	0	12	40		28	24	8		8	4	8		24	16	8		180	
Pedestrians		0				0				0				0			0	
Bicycles	0	0	0		0	0	0		0	0	0		0	0	0		0	
Railroad																		
Stopped Buses																		

Comments:

LOCATION: 11th Ave SPECIFIC LOCATION: 0 ft from Lincoln Ave CITY/STATE: Tracy, CA						QC JOB #: 12425017 DIRECTION: EB DATE: Feb 20 2014 - Feb 20 2014				
Start Time	Mon	Tue	Wed	Thu 20-Feb-14	Fri	Average Weekday Hourly Traffic	Sat	Sun	Average Week Hourly Traffic	Average Week Profile
12:00 AM				25		25			25	
12:15 AM				18		18			18	
12:30 AM				14		14			14	
12:45 AM				17		17			17	
1:00 AM				8		8			8	
1:15 AM				11		11			11	
1:30 AM				13		13			13	
1:45 AM				9		9			9	
2:00 AM				6		6			6	
2:15 AM				10		10			10	
2:30 AM				8		8			8	
2:45 AM				4		4			4	
3:00 AM				8		8			8	
3:15 AM				4		4			4	
3:30 AM				9		9			9	
3:45 AM				22		22			22	
4:00 AM				11		11			11	
4:15 AM				15		15			15	
4:30 AM				18		18			18	
4:45 AM				18		18			18	
5:00 AM				17		17			17	
5:15 AM				20		20			20	
5:30 AM				20		20			20	
5:45 AM				35		35			35	
Day Total										
% Weekday Average										
% Week Average										
AM Peak Volume										
PM Peak Volume										
<i>Comments:</i>										

LOCATION: 11th Ave SPECIFIC LOCATION: 0 ft from Lincoln Ave CITY/STATE: Tracy, CA						QC JOB #: 12425017 DIRECTION: EB DATE: Feb 20 2014 - Feb 20 2014				
Start Time	Mon	Tue	Wed	Thu 20-Feb-14	Fri	Average Weekday Hourly Traffic	Sat	Sun	Average Week Hourly Traffic	Average Week Profile
6:00 AM				28		28			28	
6:15 AM				42		42			42	
6:30 AM				76		76			76	
6:45 AM				80		80			80	
7:00 AM				81		81			81	
7:15 AM				130		130			130	
7:30 AM				263		263			263	
7:45 AM				244		244			244	
8:00 AM				200		200			200	
8:15 AM				202		202			202	
8:30 AM				172		172			172	
8:45 AM				164		164			164	
9:00 AM				138		138			138	
9:15 AM				146		146			146	
9:30 AM				127		127			127	
9:45 AM				142		142			142	
10:00 AM				179		179			179	
10:15 AM				140		140			140	
10:30 AM				168		168			168	
10:45 AM				166		166			166	
11:00 AM				163		163			163	
11:15 AM				156		156			156	
11:30 AM				170		170			170	
11:45 AM				188		188			188	
Day Total										
% Weekday Average										
% Week Average										
AM Peak Volume										
PM Peak Volume										
<i>Comments:</i>										

LOCATION: 11th Ave SPECIFIC LOCATION: 0 ft from Lincoln Ave CITY/STATE: Tracy, CA						QC JOB #: 12425017 DIRECTION: EB DATE: Feb 20 2014 - Feb 20 2014				
Start Time	Mon	Tue	Wed	Thu 20-Feb-14	Fri	Average Weekday Hourly Traffic	Sat	Sun	Average Week Hourly Traffic	Average Week Profile
12:00 PM				162		162			162	
12:15 PM				180		180			180	
12:30 PM				198		198			198	
12:45 PM				199		199			199	
1:00 PM				202		202			202	
1:15 PM				188		188			188	
1:30 PM				214		214			214	
1:45 PM				213		213			213	
2:00 PM				196		196			196	
2:15 PM				198		198			198	
2:30 PM				255		255			255	
2:45 PM				278		278			278	
3:00 PM				281		281			281	
3:15 PM				276		276			276	
3:30 PM				250		250			250	
3:45 PM				296		296			296	
4:00 PM				270		270			270	
4:15 PM				246		246			246	
4:30 PM				273		273			273	
4:45 PM				250		250			250	
5:00 PM				274		274			274	
5:15 PM				274		274			274	
5:30 PM				286		286			286	
5:45 PM				234		234			234	
Day Total										
% Weekday Average										
% Week Average										
AM Peak Volume										
PM Peak Volume										
<i>Comments:</i>										

LOCATION: 11th Ave SPECIFIC LOCATION: 0 ft from Lincoln Ave CITY/STATE: Tracy, CA						QC JOB #: 12425017 DIRECTION: EB DATE: Feb 20 2014 - Feb 20 2014				
Start Time	Mon	Tue	Wed	Thu 20-Feb-14	Fri	Average Weekday Hourly Traffic	Sat	Sun	Average Week Hourly Traffic	Average Week Profile
6:00 PM				230		230			230	
6:15 PM				241		241			241	
6:30 PM				210		210			210	
6:45 PM				207		207			207	
7:00 PM				178		178			178	
7:15 PM				172		172			172	
7:30 PM				138		138			138	
7:45 PM				123		123			123	
8:00 PM				128		128			128	
8:15 PM				112		112			112	
8:30 PM				106		106			106	
8:45 PM				104		104			104	
9:00 PM				90		90			90	
9:15 PM				72		72			72	
9:30 PM				66		66			66	
9:45 PM				72		72			72	
10:00 PM				54		54			54	
10:15 PM				42		42			42	
10:30 PM				36		36			36	
10:45 PM				40		40			40	
11:00 PM				38		38			38	
11:15 PM				28		28			28	
11:30 PM				24		24			24	
11:45 PM				40		40			40	
Day Total				12149		12149			12149	
% Weekday Average				100.0%						
% Week Average				100.0%		100.0%				
AM Peak				7:30 AM		7:30 AM			7:30 AM	
Volume				263		263			263	
PM Peak				3:45 PM		3:45 PM			3:45 PM	
Volume				296		296			296	
<i>Comments:</i>										

LOCATION: 11th Ave SPECIFIC LOCATION: 0 ft from Lincoln Ave CITY/STATE: Tracy, CA						QC JOB #: 12425017 DIRECTION: EB/WB DATE: Feb 20 2014 - Feb 20 2014				
Start Time	Mon	Tue	Wed	Thu 20-Feb-14	Fri	Average Weekday Hourly Traffic	Sat	Sun	Average Week Hourly Traffic	Average Week Profile
12:00 AM				41		41			41	
12:15 AM				29		29			29	
12:30 AM				30		30			30	
12:45 AM				27		27			27	
1:00 AM				21		21			21	
1:15 AM				21		21			21	
1:30 AM				23		23			23	
1:45 AM				19		19			19	
2:00 AM				16		16			16	
2:15 AM				16		16			16	
2:30 AM				18		18			18	
2:45 AM				14		14			14	
3:00 AM				22		22			22	
3:15 AM				28		28			28	
3:30 AM				37		37			37	
3:45 AM				48		48			48	
4:00 AM				67		67			67	
4:15 AM				89		89			89	
4:30 AM				112		112			112	
4:45 AM				132		132			132	
5:00 AM				122		122			122	
5:15 AM				132		132			132	
5:30 AM				140		140			140	
5:45 AM				158		158			158	
Day Total										
% Weekday Average										
% Week Average										
AM Peak Volume										
PM Peak Volume										
<i>Comments:</i>										

LOCATION: 11th Ave SPECIFIC LOCATION: 0 ft from Lincoln Ave CITY/STATE: Tracy, CA						QC JOB #: 12425017 DIRECTION: EB/WB DATE: Feb 20 2014 - Feb 20 2014				
Start Time	Mon	Tue	Wed	Thu 20-Feb-14	Fri	Average Weekday Hourly Traffic	Sat	Sun	Average Week Hourly Traffic	Average Week Profile
6:00 AM				145		145			145	
6:15 AM				170		170			170	
6:30 AM				185		185			185	
6:45 AM				186		186			186	
7:00 AM				198		198			198	
7:15 AM				250		250			250	
7:30 AM				459		459			459	
7:45 AM				516		516			516	
8:00 AM				506		506			506	
8:15 AM				429		429			429	
8:30 AM				360		360			360	
8:45 AM				339		339			339	
9:00 AM				304		304			304	
9:15 AM				318		318			318	
9:30 AM				289		289			289	
9:45 AM				303		303			303	
10:00 AM				371		371			371	
10:15 AM				321		321			321	
10:30 AM				325		325			325	
10:45 AM				346		346			346	
11:00 AM				353		353			353	
11:15 AM				370		370			370	
11:30 AM				384		384			384	
11:45 AM				414		414			414	
Day Total										
% Weekday Average										
% Week Average										
AM Peak Volume										
PM Peak Volume										
<i>Comments:</i>										

LOCATION: 11th Ave SPECIFIC LOCATION: 0 ft from Lincoln Ave CITY/STATE: Tracy, CA						QC JOB #: 12425017 DIRECTION: EB/WB DATE: Feb 20 2014 - Feb 20 2014				
Start Time	Mon	Tue	Wed	Thu 20-Feb-14	Fri	Average Weekday Hourly Traffic	Sat	Sun	Average Week Hourly Traffic	Average Week Profile
12:00 PM				386		386			386	
12:15 PM				418		418			418	
12:30 PM				413		413			413	
12:45 PM				417		417			417	
1:00 PM				430		430			430	
1:15 PM				384		384			384	
1:30 PM				436		436			436	
1:45 PM				429		429			429	
2:00 PM				414		414			414	
2:15 PM				406		406			406	
2:30 PM				505		505			505	
2:45 PM				526		526			526	
3:00 PM				603		603			603	
3:15 PM				591		591			591	
3:30 PM				488		488			488	
3:45 PM				530		530			530	
4:00 PM				526		526			526	
4:15 PM				489		489			489	
4:30 PM				503		503			503	
4:45 PM				510		510			510	
5:00 PM				547		547			547	
5:15 PM				538		538			538	
5:30 PM				522		522			522	
5:45 PM				456		456			456	
Day Total										
% Weekday Average										
% Week Average										
AM Peak Volume										
PM Peak Volume										
<i>Comments:</i>										

LOCATION: 11th Ave SPECIFIC LOCATION: 0 ft from Lincoln Ave CITY/STATE: Tracy, CA						QC JOB #: 12425017 DIRECTION: EB/WB DATE: Feb 20 2014 - Feb 20 2014				
Start Time	Mon	Tue	Wed	Thu 20-Feb-14	Fri	Average Weekday Hourly Traffic	Sat	Sun	Average Week Hourly Traffic	Average Week Profile
6:00 PM				478		478			478	
6:15 PM				454		454			454	
6:30 PM				390		390			390	
6:45 PM				401		401			401	
7:00 PM				334		334			334	
7:15 PM				314		314			314	
7:30 PM				273		273			273	
7:45 PM				245		245			245	
8:00 PM				248		248			248	
8:15 PM				209		209			209	
8:30 PM				205		205			205	
8:45 PM				194		194			194	
9:00 PM				190		190			190	
9:15 PM				148		148			148	
9:30 PM				118		118			118	
9:45 PM				138		138			138	
10:00 PM				124		124			124	
10:15 PM				76		76			76	
10:30 PM				74		74			74	
10:45 PM				64		64			64	
11:00 PM				72		72			72	
11:15 PM				64		64			64	
11:30 PM				45		45			45	
11:45 PM				63		63			63	
Day Total				25591		25591			25591	
% Weekday Average				100.0%						
% Week Average				100.0%		100.0%				
AM Peak Volume				7:45 AM 516		7:45 AM 516			7:45 AM 516	
PM Peak Volume				3:00 PM 603		3:00 PM 603			3:00 PM 603	
<i>Comments:</i>										

LOCATION: 11th Ave
SPECIFIC LOCATION: 0 ft from Lincoln Ave
CITY/STATE: Tracy, CA

QC JOB #: 12425017
DIRECTION: WB
DATE: Feb 20 2014 - Feb 20 2014

Start Time	Mon	Tue	Wed	Thu 20-Feb-14	Fri	Average Weekday Hourly Traffic	Sat	Sun	Average Week Hourly Traffic	Average Week Profile
12:00 AM				16		16			16	
12:15 AM				11		11			11	
12:30 AM				16		16			16	
12:45 AM				10		10			10	
1:00 AM				13		13			13	
1:15 AM				10		10			10	
1:30 AM				10		10			10	
1:45 AM				10		10			10	
2:00 AM				10		10			10	
2:15 AM				6		6			6	
2:30 AM				10		10			10	
2:45 AM				10		10			10	
3:00 AM				14		14			14	
3:15 AM				24		24			24	
3:30 AM				28		28			28	
3:45 AM				26		26			26	
4:00 AM				56		56			56	
4:15 AM				74		74			74	
4:30 AM				94		94			94	
4:45 AM				114		114			114	
5:00 AM				105		105			105	
5:15 AM				112		112			112	
5:30 AM				120		120			120	
5:45 AM				123		123			123	
Day Total										
% Weekday Average										
% Week Average										
AM Peak Volume										
PM Peak Volume										

Comments:

LOCATION: 11th Ave SPECIFIC LOCATION: 0 ft from Lincoln Ave CITY/STATE: Tracy, CA						QC JOB #: 12425017 DIRECTION: WB DATE: Feb 20 2014 - Feb 20 2014				
Start Time	Mon	Tue	Wed	Thu 20-Feb-14	Fri	Average Weekday Hourly Traffic	Sat	Sun	Average Week Hourly Traffic	Average Week Profile
6:00 AM				117		117			117	
6:15 AM				128		128			128	
6:30 AM				109		109			109	
6:45 AM				106		106			106	
7:00 AM				117		117			117	
7:15 AM				120		120			120	
7:30 AM				196		196			196	
7:45 AM				272		272			272	
8:00 AM				306		306			306	
8:15 AM				227		227			227	
8:30 AM				188		188			188	
8:45 AM				175		175			175	
9:00 AM				166		166			166	
9:15 AM				172		172			172	
9:30 AM				162		162			162	
9:45 AM				161		161			161	
10:00 AM				192		192			192	
10:15 AM				181		181			181	
10:30 AM				157		157			157	
10:45 AM				180		180			180	
11:00 AM				190		190			190	
11:15 AM				214		214			214	
11:30 AM				214		214			214	
11:45 AM				226		226			226	
Day Total										
% Weekday Average										
% Week Average										
AM Peak Volume										
PM Peak Volume										
<i>Comments:</i>										

LOCATION: 11th Ave
SPECIFIC LOCATION: 0 ft from Lincoln Ave
CITY/STATE: Tracy, CA

QC JOB #: 12425017
DIRECTION: WB
DATE: Feb 20 2014 - Feb 20 2014

Start Time	Mon	Tue	Wed	Thu 20-Feb-14	Fri	Average Weekday Hourly Traffic	Sat	Sun	Average Week Hourly Traffic	Average Week Profile
12:00 PM				224		224			224	
12:15 PM				238		238			238	
12:30 PM				215		215			215	
12:45 PM				218		218			218	
1:00 PM				228		228			228	
1:15 PM				196		196			196	
1:30 PM				222		222			222	
1:45 PM				216		216			216	
2:00 PM				218		218			218	
2:15 PM				208		208			208	
2:30 PM				250		250			250	
2:45 PM				248		248			248	
3:00 PM				322		322			322	
3:15 PM				315		315			315	
3:30 PM				238		238			238	
3:45 PM				234		234			234	
4:00 PM				256		256			256	
4:15 PM				243		243			243	
4:30 PM				230		230			230	
4:45 PM				260		260			260	
5:00 PM				273		273			273	
5:15 PM				264		264			264	
5:30 PM				236		236			236	
5:45 PM				222		222			222	
Day Total										
% Weekday Average										
% Week Average										
AM Peak Volume										
PM Peak Volume										

Comments:

LOCATION: 11th Ave SPECIFIC LOCATION: 0 ft from Lincoln Ave CITY/STATE: Tracy, CA						QC JOB #: 12425017 DIRECTION: WB DATE: Feb 20 2014 - Feb 20 2014				
Start Time	Mon	Tue	Wed	Thu 20-Feb-14	Fri	Average Weekday Hourly Traffic	Sat	Sun	Average Week Hourly Traffic	Average Week Profile
6:00 PM				248		248			248	
6:15 PM				213		213			213	
6:30 PM				180		180			180	
6:45 PM				194		194			194	
7:00 PM				156		156			156	
7:15 PM				142		142			142	
7:30 PM				135		135			135	
7:45 PM				122		122			122	
8:00 PM				120		120			120	
8:15 PM				97		97			97	
8:30 PM				99		99			99	
8:45 PM				90		90			90	
9:00 PM				100		100			100	
9:15 PM				76		76			76	
9:30 PM				52		52			52	
9:45 PM				66		66			66	
10:00 PM				70		70			70	
10:15 PM				34		34			34	
10:30 PM				38		38			38	
10:45 PM				24		24			24	
11:00 PM				34		34			34	
11:15 PM				36		36			36	
11:30 PM				21		21			21	
11:45 PM				23		23			23	
Day Total				13442		13442			13442	
% Weekday Average				100.0%						
% Week Average				100.0%		100.0%				
AM Peak				8:00 AM		8:00 AM			8:00 AM	
Volume				306		306			306	
PM Peak				3:00 PM		3:00 PM			3:00 PM	
Volume				322		322			322	
<i>Comments:</i>										