

TRACY HOMELESSNESS ADVISORY COMMITTEE REGULAR MEETING AGENDA

**Thursday, March 21, 2024, 7:00 P.M.**

Tracy City Hall, 333 Civic Center Plaza, Tracy

Web Site: [www.cityoftracy.org](http://www.cityoftracy.org)

**THIS MEETING WILL BE OPEN TO THE PUBLIC FOR IN-PERSON AND  
REMOTE PARTICIPATION PURSUANT TO GOVERNMENT CODE  
SECTION 54953(e).**

**MEMBERS OF THE PUBLIC MAY PARTICIPATE REMOTELY IN THE MEETING VIA  
THE FOLLOWING METHOD:**

*As always, the public may view the Tracy Homelessness Advisory Committee meetings live on the City of Tracy's website at [CityofTracy.org](http://CityofTracy.org) or on Comcast Channel 26/AT&T U-verse Channel 99. To view from the City's website, open the "Government" menu at the top of the City's homepage and select "Tracy Homelessness Advisory Committee", then select "[View Homelessness Advisory Committee Meetings on YouTube](#)" under the "Boards and Commissions" section.*

*If you only wish to watch the meeting and do not wish to address the Council, the City requests that you stream the meeting through the City's website or watch on Channel 26.*

**Remote Public Comment:**

*During the upcoming Homelessness Advisory Committee meeting public comment will be accepted via the options listed below. If you would like to comment remotely, please follow the protocols below:*

- *Comments via:*
  - **Online by visiting <https://cityoftracyevents.webex.com>** and using the following **Event Number: 2559 594 8864** and **Event Password: THAC**
  - ***If you would like to participate in the public comment anonymously***, you may submit your comment in WebEx by typing "Anonymous" when prompted to provide a First and Last Name and inserting [Anonymous@example.com](mailto:Anonymous@example.com) when prompted to provide an email address.
  - ***Join by phone by dialing +1-408-418-9388, enter 25595948864#8422# Press \*3 to raise the hand icon to speak on an item.***
  
- *Protocols for commenting via WebEx:*
  - *If you wish to comment on the "Consent Calendar", "Items from the Audience/Public Comment" or "Regular Agenda" portions of the agenda:*
    - *Listen for the Chairperson to open that portion of the agenda for discussion, then raise your hand to speak by clicking on the Hand icon on the Participants panel to the right of your screen.*
    - *If you no longer wish to comment, you may lower your hand by clicking on the Hand icon again.*

- *Comments for the “Consent Calendar” “Items from the Agenda/Public Comment” or “Regular Agenda” portions of the agenda will be accepted until the public comment for that item is closed.*

Government Code Section 54954.3 states that every public meeting shall provide an opportunity for the public to address the Tracy Homelessness Advisory Committee on any item, before or during consideration of the item, however no action shall be taken on any item not on the agenda.

Full copies of the agenda are available on the City’s website: [www.cityoftracy.org](http://www.cityoftracy.org)

CALL TO ORDER  
ROLL CALL

1. CONSENT CALENDAR

- 1.A. Adoption of September 26, 2023 Special Meeting Minutes, October 19, 2023 Regular Meeting Minutes and February 15, 2024 Regular Meeting Minutes

2. ITEMS FROM THE AUDIENCE - *In accordance with Council Meeting Protocols and Rules of Procedure*, adopted by Resolution 2019-240, a five-minute maximum time limit per speaker will apply to all individuals speaking during “Items from the Audience/Public Comment”. For non-agendized items, Advisory Committee members may briefly respond to statements made or questions posed by individuals during public comment; ask questions for clarification; direct the individual to the appropriate staff member; or request that the matter be placed on a future agenda or that staff provide additional information to the Tracy Homelessness Advisory Committee.

3. REGULAR AGENDA

- 3.A. The Tracy Homelessness Advisory Committee receive an informational report regarding the City’s ongoing efforts regarding homeless encampments.

- 3.B. The Tracy Homelessness Advisory Committee recommend that the City Council adopt a Resolution approving Amendment No. 1 to the General Services Agreement with SC Commercial LLC, DBA SC Fuels at the Temporary Emergency Housing Facility, CIP 71112, at 370 Arbor Avenue, to amend the scope of work to include the installation and rental of a 500-gallon auxiliary fuel tank for generator #3 for a monthly rental and monitoring fee of \$265.

- 3.C. The Tracy Homelessness Advisory Committee recommend that the City Council adopt a Resolution (1) determining that compliance with the standard procurement process is not in the best interest of the City pursuant to California Public Contract Code Section 20301 and Tracy Municipal Code Section 2.20.180(b)(4) for entering into a two agreements with PowerGen, Inc. for the rental and maintenance of diesel generators required at the Temporary Emergency Housing Facility; (2) approving an interim General Services Agreement with PowerGen, Inc. for nine (9) months effective July 1, 2023 through March 31, 2024 with a not-to exceed amount to \$617,539.47; (3) approving a new General Services Agreement with PowerGen, Inc. with a not

to exceed amount of \$657,253.70 with an initial term from April 1, 2024 through June 30, 2025; and (4) authorizing the City Manager to extend the Agreement up to one additional year, subject to the not-to-exceed amount.

- 3.D The Tracy Homeless Advisory Committee recommend that the City Council adopt a resolution (1) determining that compliance with the standard procurement process is not in the best interest of the City pursuant to California Public Contract Code Section 20301 and Tracy Municipal Code Section 2.20.180(b)(4), and (2) approving a Purchase Agreement with Nelco Electrical Supply, Inc., in the amount of \$391,636.58, for the purchase of electrical equipment required for permanent power supplies.

4. STAFF ITEMS

5. COMMITTEE ITEMS

6. ADJOURNMENT

Posting Date: **March 18, 2024**

The City of Tracy is in compliance with the Americans with Disabilities Act and will make all reasonable accommodations for the disabled to participate in employment, programs and facilities. Persons requiring assistance or auxiliary aids in order to participate, should contact the City Manager's Office at (209) 831-6000 at least 24 hours prior to the meeting.

September 26, 2023, 7:00 p.m.

Tracy City Hall, 333 Civic Center Plaza, Tracy, CA 95376

CALL TO ORDER – Chairperson Davis called the meeting to order at 7:03 pm

ROLL CALL – Deputy City Clerk. Roll call found Chairperson Davis and Vice Chairperson Bedolla

1. Motion was made by Vice Chairperson Bedolla and seconded by Chairperson Davis to adopt the Consent Calendar. All in favor, passed and so ordered.

1.A Adoption of the May 18, 2023 Special Meeting Minutes-**Minutes were adopted**

2. ITEMS FROM THE AUDIENCE –

Bryson Yager, spoke about the health concerns his girlfriend is experiencing at the shelter and how City Net staff is not following COVID-19 safety protocol and is not receiving proper case management.

Elizabeth Barrejas, former shelter resident, expressed her concerns that COVID-19 protocol was not being followed and practiced by City Net staff. She also expressed her concerns with the lack of necessities provided by the staff like toilet paper and hand soap.

Lauren Taylor, resident of the shelter, spoke about how she was not properly informed that COVID-19 was active in the dorm that she was moved into and contracted the virus.

Brent Fonseca, resident of the shelter, spoke about an incident where he was assaulted near Denny's and how he was treated by the police department.

Veronica Vega, resident of the shelter, indicated that she also got COVID-19 and stays in the same modular as the other resident who contracted the virus. She was also not informed of the COVID-19 outbreak by City Net staff.

Bobby, resident of the shelter, expressed his frustration that he and his wife are being threatened of being exited from the shelter as they refuse to return to their dorm until the COVID quarantine is over. He was also upset that he had to throw away his bikes and trailers because of the new shelter manager from City Net.

Bernadette Richards, was recently exited from the shelter and expressed her frustration with City Net's write up policy and guidelines.



Cynthia Camacho, spoke about the lack of communication she has had with the Homeless Services Manager in being able to express her concerns of the issues going on at the shelter.

Kendra, resident of the shelter, shared that she also got COVID and was hospitalized. She shared that City Net staff did not follow proper COVID protocol and is still not doing anything to help the shelter guests.

### 3. REGULAR AGENDA

#### 3.A The Tracy Homelessness Advisory Committee receive an informational report regarding the implementation of the City Council Strategic Plan to End and Prevent Homelessness and the most recent Emergency Interim Shelter activities.

Virginia Carney, Homeless Services Manager provided the staff report, presentation and responded to questions.

Brent Fonseca, shared that he feels that the City of Tracy can be the role model for other cities on how to help serve the homeless community and asked for the City to talk to the warehouses in town to create work programs for the unhoused.

Cynthia Camacho, asked if the Homeless Services Manager can confirm that the shelter guest are receiving the services being presented in the slides like food and clothing.

Committee questions and comments followed.

Brad Fieldhouse talked about the COVID-19 protocol that City Net is implementing and following at the shelter.

Chief Millington informed the committee that the team is currently working with IT to implement the Camp2Home dashboard that will provide real time data of the unhoused population in Tracy. Right now the data received is manual, but the Familiar Faces team is familiar with the unhoused at the parks and surrounding areas.

Committee comments followed.

#### 3.B The Tracy Homelessness Advisory Committee recommend that the City Council adopt a resolution awarding a professional service agreement to The Salvation Army to serve as the City's shelter operator for the Temporary Emergency Housing Facility, with an initial term of one (1) year and a not-to-exceed annual cost of \$2.6 Million.

Virginia Carney, Homeless Services Manager provided the staff report, presentation and responded to questions.

Committee comments and questions followed.

Captain Juan Oregel with The Salvation Army spoke about implementing various programs and services to the shelter that have been successful at other Salvation Army facilities and provided an overview of the daily operations for the shelter. He also shared his own personal success story with the help of The Salvation Army and how he wants to provide that support to the shelter guest.

Major John Brackenbury shared that the City of Tracy does not only have The Salvation Army on there side, but the whole division and the resources they have available.

Cynthia Camacho expressed that she looks forward to The Salvation Army taking over the shelter and the change that they will bring.

Brad Fieldhouse congratulated The Salvation Army on the awarded contract to operate the shelter and that City Net will finish well and strong until the keys are turned over to the new operator.

**ACTION:** Motion was made by Vice Chairperson Bedolla and seconded by Chairperson Davis that the Tracy Homelessness Advisory Committee recommend that the City Council adopt a resolution awarding a professional service agreement to The Salvation Army to serve as the City's shelter operator for the Temporary Emergency Housing Facility, with an initial term of one (1) year and a not-to-exceed annual cost of \$2.6 Million. Roll call found all in favor; passed and so ordered.

3.C The Tracy Homelessness Advisory Committee recommend that the City Council adopt a resolution (1) making a determination that United Site Services provides unique products and services that are not available from other sources, therefore compliance with standard procurement process is not in the best interest of the City and (2) approving general services agreement with United Site Services of California, Inc. with a not-to-exceed amount of \$125,000 to provide temporary showers and restrooms to Phase IV-Custom Container occupants until permanent bathrooms are installed under Phase II-Site Improvements at the Temporary Emergency Housing Facility, CIP 71112, at 370 West Arbor Avenue.

Ilene Macintire, Senior Civil Engineer provided the staff report and responded to questions.

No public comment.

No committee questions or comments.

**ACTION:** Motion was made by Vice Chairperson Bedolla and seconded by Chairperson Davis that the Tracy Homelessness Advisory Committee recommend that the City Council adopt a resolution (1) making a determination that United Site Services provides unique products and services that are not available from other sources, therefore compliance with standard procurement process is not in the best interest of the City and (2) approving general services agreement with United Site Services of California, Inc. with a not-to-exceed amount of \$125,000 to provide temporary showers and restrooms to Phase IV-Custom Container occupants until permanent bathrooms are installed under Phase II-Site

Improvements at the Temporary Emergency Housing Facility, CIP 71112, at 370 West Arbor Avenue. Roll call found all in favor; passed and so ordered.

- 3.D The Tracy Homelessness Advisory Committee recommend that the City Council adopt a Resolution to (1) approve the Professional Services Agreement with Roebbelen Construction Management Services, Inc. for construction management services for Phase II Site Improvements at the Temporary Emergency Housing Facility, CIP 71112, located at 370 W. Arbor Avenue, with a total not-to-exceed amount of \$450,185.

Brian MacDonald, Interim Assistant City Manager, introduced Nilo Velazquez to the committee before presenting the staff report.

Nilo Velazquez, Management Analyst II provided the staff report and responded to questions.

Committee questions and comments followed.

Ilene Macintire, Senior Civil Engineer responded to questions.

Committee comments followed.

No public comment.

**ACTION:** Motion was made by Vicechair Bedolla and seconded by Chairperson Davis that the Tracy Homelessness Advisory Committee recommend that the City Council adopt a Resolution to (1) approve the Professional Services Agreement with Roebbelen Construction Management Services, Inc. for construction management services for Phase II Site Improvements at the Temporary Emergency Housing Facility, CIP 71112, located at 370 W. Arbor Avenue, with a total not-to-exceed amount of \$450,185. Roll call found all in favor; passed and so ordered.

- 3.E The Tracy Homelessness Advisory Committee recommend that the City Council adopt a resolution approving a professional services agreement with Trine Integrated Services, Inc. for security services for a total amount not to exceed \$150,000 for a term of three months.

Brian MacDonald, Interim Assistant City Manager, requested Item 3.E be pulled from the agenda.

No public comment.

**ACTION:** No motion made by committee as item was pulled.

4. STAFF ITEMS – None  
5. COMMITTEE ITEMS – None

6. ADJOURNMENT – Time: 9:21 p.m.

**ACTION:** Motion was made by Vice Chairperson Bedolla and seconded by Chairperson Davis to adjourn. Roll call found all in favor; passed and so ordered.

The agenda was posted at City Hall on September 25, 2023. The above are action minutes.

\_\_\_\_\_  
Chairperson

ATTEST:

\_\_\_\_\_  
Administration Technician

Thursday, October 19, 2023, 7:00 p.m.

Tracy City Hall, 333 Civic Center Plaza, Tracy, CA 95376

CALL TO ORDER – Chairperson Davis called the meeting to order at 7:03 PM

ROLL CALL – Deputy City Clerk. Roll call found Chairperson Davis and Vice Chairperson Bedolla

1. Motion was made by Vice Chairperson Bedolla and seconded by Chairperson Davis to adopt the Consent Calendar. All in favor, passed and so ordered.

1.A Adoption of the June 15, 2023 and August 17, 2023 Regular Meeting Minutes- Minutes were adopted

2. ITEMS FROM THE AUDIENCE –Joanne Gregonis asked for clarification on where the unhoused can go if they are kicked out of a hotel or place and if they can return to El Pescadero.

3. REGULAR AGENDA

3.A The Tracy Homelessness Advisory Committee receive an informational report regarding the implementation of the City Council Strategic Plan to End and Prevent Homelessness and the most recent Emergency Interim Shelter activities.

Brian MacDonald, Interim Assistant City Manager provided the staff report, presentation and responded to questions.

Ana Contreras, Community Preservation Manager presented and responded to questions.

Ilene Macintire, Senior Civil Engineer presented and responded to questions.

Ayesha Nic-Gongora responded to the public comment question by providing a brief description of the outreach process conducted by Familiar Faces and that only those exited from the shelter are allowed to return to El Pescadero park.

Alice English expressed her frustration with learning that the unhoused can return to the park if exited from the shelter.

Committee questions and comments followed.

- 3.B The Tracy Homelessness Advisory Committee recommend that the City Council adopt a Resolution: 1) Authorizing the acceptance of a grant award from Health Plan of San Joaquin in the amount of \$595,000 to partially fund the continued operation of the Tracy Interim Shelter Site; and 2) Appropriating the total grant funds to the Mobility and Housing Department, Homeless Services Division budget.

Brian MacDonald, Interim Assistant City Manager provided the staff report, presentation and responded to questions.

Committee comments and questions followed.

Ayesha Nic-Gongora shared that the shelter is not currently conducting intakes as they are following COVID-19 protocols and clients interested in the shelter can contact Familiar Faces or TCCC.

Telia Wells-Lawrence, Program Manager for City Net shared that the only opening at the shelter is in the shared female dorm and that guest has COVID. Shelter is unable to accept intakes at this time.

**ACTION:** Motion was made by Vice Chairperson Bedolla and seconded by Chairperson Davis that the Tracy Homelessness Advisory Committee recommend that the City Council a Resolution: 1) Authorizing the acceptance of a grant award from Health Plan of San Joaquin in the amount of \$595,000 to partially fund the continued operation of the Tracy Interim Shelter Site; and 2) Appropriating the total grant funds to the Mobility and Housing Department, Homeless Services Division budget. Roll call found all in favor; passed and so ordered.

- 3.C The Tracy Homelessness Advisory Committee recommend that the City Council adopt a Resolution (1) approving Amendment No. 1 to the General Services Agreement (Agreement) with United Fence Services, Inc., to extend the term of the Agreement through December 31, 2024 for the rental of fence panels, stands and safety brackets required at the Temporary Emergency Housing Facility (TEHF).

Ilene Macintire, Senior Civil Engineer provided the staff report and responded to questions.

Joanne Gregonis spoke about the upcoming bed availability at the shelter and once those spots fill up what happens to those in the park if they have to move out by October 31<sup>st</sup> and the new beds are not available.  
No committee questions or comments.

Public speaker asked if there are any programs or services to prevent homelessness.

No committee questions or comments.

**ACTION:** Motion was made by Vice Chairperson Bedolla and seconded by Chairperson Davis that the Tracy Homelessness Advisory Committee recommend that the

City Council adopt a Resolution (1) approving Amendment No. 1 to the General Services Agreement (Agreement) with United Fence Services, Inc., to extend the term of the Agreement through December 31, 2024 for the rental of fence panels, stands and safety brackets required at the Temporary Emergency Housing Facility (TEHF). Roll call found all in favor; passed and so ordered.

4. STAFF ITEMS – None
5. COMMITTEE ITEMS – None
6. ADJOURNMENT – Time: 8:00 p.m.

**ACTION:** Motion was made by Vice Chairperson Bedolla and seconded by Chairperson Davis to adjourn. Roll call found all in favor; passed and so ordered.

The agenda was posted at City Hall on October 16, 2023. The above are action minutes.

\_\_\_\_\_  
Chairperson

ATTEST:

\_\_\_\_\_  
Administration Technician

Thursday, February 15, 2024, 7:00 p.m.

Tracy City Hall, 333 Civic Center Plaza, Tracy, CA 95376

CALL TO ORDER – Chairperson Davis called the meeting to order at 7:02 PM

ROLL CALL – Deputy City Clerk. Roll call found Chairperson Davis and Vice Chairperson Bedolla

1. ITEMS FROM THE AUDIENCE – No public comment.

2. REGULAR AGENDA

3.A The Tracy Homelessness Advisory Committee receive an informational update regarding homeless services and the Temporary Emergency Housing Facility project.

Virginia Carney, Homeless Services Manager provided the staff report, presentation and responded to questions.

Vernal Shaw asked if shelter guests need to leave the shelter in the mornings and asked for aid for an unhoused man in front of Safeway.

Cynthia Camacho asked what can be done for those unhoused individuals who refuse assistance.

Committee questions and comments followed.

Captain Juan Oregel with The Salvation Army responded to committee questions and comments.

Committee questions and comments continued.

3.B The Tracy Homelessness Advisory Committee recommend that the City Council adopt a Resolution approving Amendment No. 1 to the General Services Agreement with B.I.C. Sec Security, Inc. for installation of the Phase IV Custom Container Fire Alarm System at the Temporary Emergency Housing Facility, CIP 71112, at 370 Arbor Avenue, to amend the scope of work and increase the total compensation by \$7,491.24 for a total Not-To-Exceed amount of \$66,787.58.

Ilene Macintire, Senior Civil Engineer provided the staff report and responded to questions.



No public comment

Committee comments and questions followed.

**ACTION:** Motion was made by Vice Chairperson Bedolla and seconded by Chairperson Davis that the Tracy Homelessness Advisory Committee recommend that the City Council adopt a Resolution approving Amendment No. 1 to the General Services Agreement with B.I.C. Sec Security, Inc. for installation of the Phase IV Custom Container Fire Alarm System at the Temporary Emergency Housing Facility, CIP 71112, at 370 Arbor Avenue, to amend the scope of work and increase the total compensation by \$7,491.24 for a total Not-To-Exceed amount of \$66,787.58. Roll call found all in favor; passed and so ordered.

3. STAFF ITEMS – None
5. COMMITTEE ITEMS – None
6. ADJOURNMENT – Time: 8:02 p.m.

**ACTION:** Motion was made by Vice Chairperson Bedolla and seconded by Chairperson Davis to adjourn. Roll call found all in favor; passed and so ordered.

The agenda was posted at City Hall on February 12, 2024. The above are action minutes.

---

Chairperson

ATTEST:

---

Administration Technician

Agenda Item 3.A

RECOMMENDATION

**Staff recommends the Tracy Homelessness Advisory Committee receive an informational report regarding the City's ongoing efforts regarding homeless encampments.**

EXECUTIVE SUMMARY

This informational report provides an update regarding the City's efforts to address quality of life and public safety concerns related to homeless encampments. The Community Services Division of the Tracy Police Department has taken lead on Homeless Outreach and response to encampment cleanups. The Community Services Division includes our Code Enforcement Unit, Neighborhood Resource Officers, Familiar Faces Homeless Outreach Team, Mobile Evaluation Team (MET) along with our Animal Services Unit. In addition, the Tracy Police Department coordinates with our internal City of Tracy Departments, to include Public Works, Parks, and South County Fire, to address blight, hazards to the public and law violations.

BACKGROUND AND LEGISLATIVE HISTORY

The Tracy Police Department's Familiar Faces Program is one component of the City's commitment to addressing the challenges of homelessness in the community. The Familiar Faces Team has been able to establish a connection with our City's most acute individuals who suffer from homelessness and or mental health issues.

With the relocation of homeless individuals to the Tracy Emergency Housing Shelter in December of 2023, coupled with our Familiar Faces Homeless Outreach efforts to offer diversion resources collectively, the City of Tracy team has successfully closed three encampments and relocated individuals seeking services. The closed encampments include El Pescadero Park, Detention Basin 4 (Macarthur Drive), and Detention Basin 5 (Plascencia Fields) and Pescadero and Paradise private property.

On 12/05/23, the Tracy City Council approved an amendment to the Tracy Municipal Code designating City of Tracy Parks as "sensitive areas." The updated municipal code has provided clear direction to law enforcement as to how to address individuals who seek to establish encampments within our City park infrastructure.

ANALYSIS

**Current Homeless Encampment Activity**

With the adoption of the new municipal code, transient activity has significantly shifted from our City Parks and Public Spaces to private properties to include Caltrans, Union Pacific Railroad and privately owned lands. The Tracy Police Department's Community Services Division, Code Enforcement Unit has been proactive by partnering with Caltrans, Union Pacific Railroad and private property owners to advise and assist with coordinated clean-ups and trespass advisements. Typically, City staff will identify encampment locations on private properties and inform the respective property managers. Our Familiar Faces team will extend our services and

offer resources to those individuals on Caltrans, Union Pacific Railroad and private properties. Staff is currently reviewing existing Memorandums of Understanding which will allow City staff to proactively cleanup and invoice Caltrans.

### **Encampment Outreach Activity**

Daily checks of our City parks, spaces, and private properties are ongoing. The Familiar Faces team continues to assist with coordinating shelter intake, transportation, and networking with non-profit and faith-based providers to identify gaps and solutions to address the unique challenges faced by those experiencing homelessness in our community. Police Dispatch and Police Patrol teams continue to work collaboratively with our Familiar Faces Homeless Outreach Team to offer services to individuals in need.

### **Upcoming Grants**

The Tracy Police Department once again partnered with the San Joaquin County Behavioral Health Services and has been given a third grant award this time in the amount of \$336,350.00 through the California Department of Health Care, Behavioral Health Justice Intervention Services. This item will be presented to the Finance Committee in late March of 2024. The grant award would fund for one year, one new Administrative Assistant position and one new Homeless Outreach Coordinator from (January 1, 2024, to March 31<sup>st</sup>, 2025). The Homeless Outreach position would be assigned to out MET unit and the Administration Assistant will provide administrative assistance to our Community Services Division. In addition, the remaining award will be used to fund continued consultant services, equipment, and operating expenses.

### **FISCAL IMPACT**

This update is provided as an informational report only.

### **COORDINATION**

The Tracy Police Department has coordinated with San Joaquin County Behavioral Health and the City of Tracy Homeless Services Division.

### **STRATEGIC PLAN**

This agenda item relates to the City of Tracy Council Strategic Priorities for 2024-2025, Quality of Life, Goal #5 continue to implement the adopted Homelessness Strategic plan.

### **ACTION REQUESTED OF THE HOMELESS ADVISORY COMMITTEE**

Staff recommends the Tracy Homelessness Advisory Committee receive an informational report regarding the City's ongoing efforts regarding homeless encampments.

Prepared by: Miguel Contreras, Police Lieutenant

Reviewed by: Octavio Lopez, Police Captain  
Beth Lyons-McCarthy, Police Support Operations Manager  
Sekou Millington, Chief of Police  
Sara Cowell, Finance Director  
Kimberly Murdaugh, Interim Assistant City Manager

Approved by: Midori Lichtwardt, City Manager

### ATTACHMENTS

Attachment A- PD Community Services Division, Tracy Homelessness Advisory Committee Update PowerPoint



# PD Community Services Division

Tracy Homeless Advisory Committee Update



Think Inside the Triangle™

	<b>LT. MIGUEL CONTRERAS</b>  <b>CSD LIEUTENANT</b>
	<b>SGT. DANIEL GARCIA</b>  <b>CSD SERGEANT</b>
	<b>SGT. BRIAN WILMSHURST</b>  <b>TRAFFIC SERGEANT</b>
	<b>MGR. ANA CONTRERAS</b>  <b>CODE ENFORCEMENT</b>

# COMMUNITY SERVICES DIVISION

- Neighborhood Resources Officers
- Familiar Faces Team
- Mobile Evaluation Team
- Code Enforcement Unit
- School Resource Officers
- DARE
- Traffic Safety Unit
- Volunteers in Police Services
- Crime Prevention Specialist

# Community Services Division

## Neighborhood Resources Officers



**ROBERT BRANDI**



**DWAYNE PAVESLKI**



**FRANK STRONG**



Think Inside the 'Triangle'

# Community Services Division

- Familiar Faces Homeless Outreach Team (FEB.24)

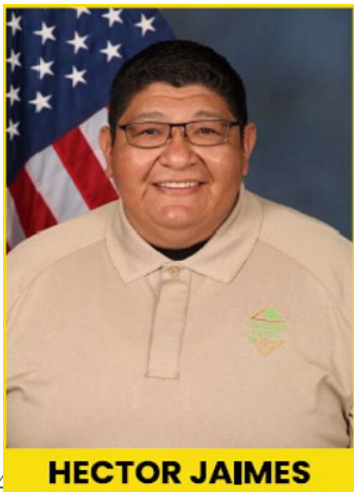

## Monthly Activities

	New Clients Enrolled to National HMIS Database <b>24</b>
	Outreach Contacts <b>28</b>
	Case Management Sessions <b>63</b>
	Service Transports <b>40</b>

## Monthly Accomplishments

	Housing Obtained <b>1</b>
	Shelter Enrollments <b>8</b>
	Vital Documents Obtained <b>3</b>
	Obtained Mental Health Services <b>1</b>



# Community Services Division

- **Mobile Evaluation Team (MET) (JAN.24)**



**DWAYNE PAVESLKI**



**GISELL CASTILLO**

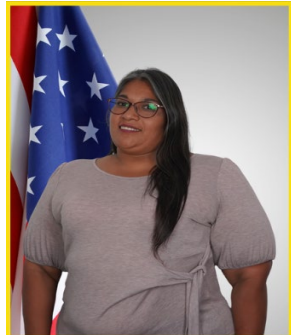

**ROSALVA SANDOVAL**



**TATIANA JACKSON**

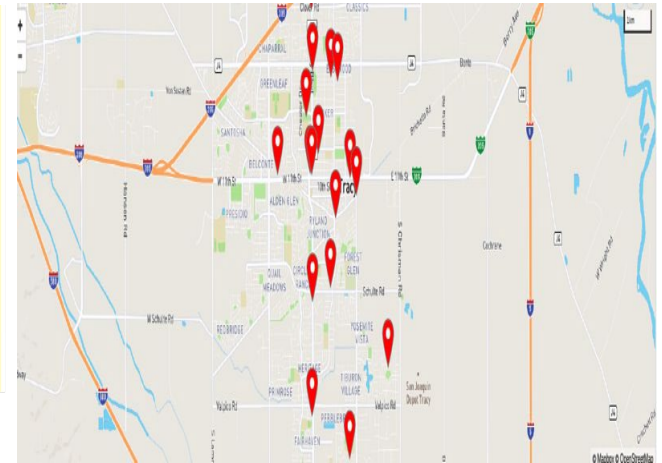

## Summary of Activities

- 01/14/24: Patrol referral of services to MET.
- 01/17/24: Patrol referral of services to MET.
- 01/17/24: Patrol referral of services to MET.
- 01/23/24: Patrol referral of services to MET.
- 01/25/24: Patrol referral of services to MET.
- 01/25/24: Patrol referral of services to MET.
- 01/25/24: Patrol referral of services to MET.
- 01/25/24: Patrol referral of services to MET (arrested for PC 243(e)(1)).
- 01/27/24: Patrol referral of services to MET.

## Summary of Activities

- 01/17/24: MET welfare check/evaluation conducted.
- 01/19/24: MET welfare check/evaluation conducted and transported to adult mental health for services.
- 01/23/24: MET welfare check/evaluation conducted.
- 01/24/24: MET welfare check/evaluation conducted and transported to adult mental health for services.
- 01/24/24: MET welfare check/evaluation conducted.
- 01/25/24: MET welfare check/evaluation conducted.
- 01/31/24: MET welfare check/evaluation conducted.
- 01/31/24: MET welfare check/evaluation conducted and transported to adult mental health for services.
- 01/31/24: MET welfare check/evaluation conducted and transported to adult mental health for services.



Think Inside the 'Triangle'

# PREVIOUS HOMELESS ENCAMPMENTS

EL PESCADERO PARK (December 20<sup>th</sup> 2023)





# PREVIOUS HOMELESS ENCAMPMENTS

## EL PESCADERO PARK



Think Inside the Triangle™



# PREVIOUS HOMELESS ENCAMPMENTS

## DETENTION BASIN 4 (MACARTHUR DRIVE)

BEFORE



AFTER



# PRIVATE PROPERTY

## Pescadero Avenue and Paradise Road

BEFORE



AFTER





# PRIVATE PROPERTY

## 530 W. Grantline Road





Think Inside the Triangle™

# New Encampments

- City-wide checks of our over 70 parks are conducted on a weekly basis to include utilizing drone fly overs.
- City staff has identified an increase in tents on Private Properties to include Cal-Trans and Union Pacific Railroad.
- Our Community Services Division has coordinated with Cal-Trans and Unions Pacific Railroad for Outreach, Enforcement and Cleanups.
- Staff is researching prior MOU with Caltrans.



# CALTRANS PROPERTY

Highway 205 and Naglee  
Road Exit



Under Highway 205 /  
Macarthur Drive





# CALTRANS PROPERTY

Highway 205 and Holly Dr.



Highway 205 and Naglee Rd



# Upcoming

- Present a Matching Grant in the amount of \$336,350.00 to fund one new Administrative Assistant and one new Homeless Outreach Coordinator (MET)
- New CAD Deposition Codes for Patrol (Familiar Faces) and (MET)
- Update Homeless Outreach Pamphlets





# CONTACT INFORMATION

- [Familiar Faces | Tracy Police Department \(tracycpd.com\)](https://www.tracycpd.com)



**Familiar Faces Hotline**

**(209) 831-6640**



**Email**

**[PDFamiliarFaces@TracyPD.com](mailto:PDFamiliarFaces@TracyPD.com)**





Agenda Item 3.B

RECOMMENDATION

**Staff recommends that the Tracy Homelessness Advisory Committee recommend that the City Council adopt a Resolution approving Amendment No. 1 to the General Services Agreement with SC Commercial LLC, DBA SC Fuels at the Temporary Emergency Housing Facility, CIP 71112, at 370 Arbor Avenue, to amend the scope of work to include the installation and rental of a 500-gallon auxiliary fuel tank for generator #3 for a monthly rental and monitoring fee of \$265.**

EXECUTIVE SUMMARY

An amendment to the General Services Agreement (Agreement) with SC Commercial LLC, DBA SC Fuels (Contractor) is required to increase fuel supply at the City's Temporary Emergency Housing Facility, City Capital Improvement Project (CIP) No. 71112, located at 370 Arbor Avenue, Tracy, CA 95304 (Project Site). The original not-to-exceed amount of \$500,000 under the Agreement will not be modified by this proposed amendment nor the original term, which is \$500,000.

The proposed amendment will: 1) modify the original scope of work to include installation and rental of a 500-gallon auxiliary fuel tank for generator #3 to prevent loss of power due to lack of fuel supply and eliminate the need for an additional day of fuel delivery, and 2) include the monthly rental fee of \$250 for the auxiliary tank and additional monthly monitoring fee of \$15 for a total of \$265. The total compensation will include the amounts as set forth in Exhibits "B" and "B-1." Upon approval of this item, the City will pay the Contractor the amount stated in Exhibit B-1.

BACKGROUND AND LEGISLATIVE HISTORY

On August 15, 2023, the City Council adopted Resolution No. 2023-143 approving an Agreement with Contractor for on-demand mobile fueling of diesel fuel at the Temporary Emergency Housing Facility at 370 W. Arbor Avenue, Tracy, CA 95304.

The opening of the additional dormitories under Phase IV-Custom Containers has caused an increase in power and fuel demand. Therefore, an amendment to the Agreement is required for Contractor to install a 500-gallon auxiliary fuel tank for generator #3. The rental of the auxiliary fuel tank will prevent loss of power due to the fuel running out and eliminate the need for an additional day of fuel delivery. This service was not included in the original scope of work.

ANALYSIS

An amendment to the Agreement is required to modify the original scope of work to include installation of a 500-gallon auxiliary fuel tank to prevent loss of power until the permanent power is installed at the Temporary Emergency Housing Facility.

The Amendment compensates the Contractor for the additional monthly rental fee for the auxiliary tank and the monthly monitoring fee. The total compensation will include the amounts as set forth in Exhibits "B" and "B-1." Upon approval of this item, the City will pay the

Contractor the amount stated in Exhibit B-1. The original Agreement not to exceed amount of \$500,000, is unchanged.

#### Fiscal Impact

Approval of the Amendment does not have any fiscal impact. The not-to-exceed amount of \$500,000 is unchanged.

#### CEQA DETERMINATION

Government Code section 8698.4 exempts the application of the California Environmental Quality Act (CEQA) to various actions taken by public agencies to implement the construction of a homeless shelter in response to a declared shelter crisis. In addition, the interim solutions taken thus far are in furtherance of and related to the permanent solution that will be implemented, referred to as the Temporary Emergency Housing Project on Arbor Avenue (CIP 71112). A Notice of Exemption was issued on October 16, 2020, for the Temporary Emergency Housing site at 500 Arbor Avenue in accordance with Government Code sections 65660-65662 for Low Barrier navigation Centers and Section 15269c) of the CEQA Guidelines (14 Cal. Code Regs. 15269(c) for (Emergency Projects). No environmental impacts beyond those already analyzed for the CIP exist; accordingly, no further CEQA analysis is needed.

#### STRATEGIC PLAN

This agenda item supports the Public Safety Strategic Priority, *Implement the adopted Homelessness Strategic Plan*.

#### ACTION REQUESTED OF THE CITY COUNCIL

Staff recommends that the Tracy Homelessness Advisory Committee recommend that the City Council adopt a Resolution approving Amendment No. 1 to the General Services Agreement with SC Commercial LLC, DBA SC Fuels at the Temporary Emergency Housing Facility, CIP 71112, at 370 Arbor Avenue, to amend the scope of work to include the installation and rental of a 500-gallon auxiliary fuel tank for generator #3 for a monthly rental and monitoring fee of \$265.

Prepared by: Jim Thompson, Operations Superintendent of Public Works

Reviewed by: Sara Cowell, Director of Finance  
Bijal Patel, City Attorney  
Kimberly Murdaugh, Interim Assistant City Manager

#### ATTACHMENTS

Attachment A – Amendment No. 1 SC Commercial LLC, DBA SC Fuels  
Attachment B – GSA SC Commercial LLC, DBA SC Fuels

**CITY OF TRACY**  
**AMENDMENT NO. 1 TO GENERAL SERVICES AGREEMENT WITH SC COMMERCIAL,**  
**LLC, DBA SC FUELS**

This Amendment No. 1 (**Amendment**) to the General Service Agreement is entered into between the City of Tracy, a municipal corporation (**City**), and SC Commercial, LLC, DBA SC Fuels (**Contractor**). City and Consultant are referred to individually as "**Party**" and collectively as "**Parties**."

**Recitals**

- A.** The City and Contractor entered into a General Services Agreement (**Agreement**) for the Temporary Emergency Housing Facility to provide diesel fuel at 370 W. Arbor Road, Tracy, CA 95304 for four generators with an estimated capacity of 300 gallons each with two active at all times and an additional two backups and spare fuel tank. This location is considered an on-demand mobile fueling operation, which was approved by the City Council on August 15, 2023 under Resolution No. 2023-143.
- B.** The opening of the additional dormitories under Phase IV-Custom Containers has caused an increase in fuel demand. The Contractor will install a 500-gallon auxiliary fuel tank for generator #3. The rental of the auxiliary fuel tank will prevent loss of power due to the fuel running out and eliminate the need for an additional day of fuel delivery.
- C.** The City and Contractor now seek to amend the Agreement to include the rental fee of \$250 a month for the 500-gallon auxiliary fuel tank for generator #3 and an additional monitor fee of \$15 a month.
- D.** This Amendment is being executed pursuant to Resolution No. \_\_\_\_\_, which was approved by Tracy City Council on \_\_\_\_\_.

**Now therefore, the Parties mutually agree as follows:**

**1. Incorporation by Reference.** Unless specifically modified by this Amendment, the Agreement shall remain unchanged and in full force and effect. By their signatures below, the parties hereto hereby ratify, approve, and confirm the Agreement remains in full force and effect. This Amendment incorporates by reference all terms set forth in the Agreement, unless specifically modified by this Amendment. All capitalized terms used herein and not defined herein shall have the meanings set forth in the Agreement.

**2. Terms of Amendment.**

A. Section 1 is hereby amended to read as follows:

"**1. Scope of Work.** Contractor shall perform the services described in Exhibit "A" and "A-1" attached and incorporated by reference. The services shall be performed by, or under the direct supervision of, Contractor's Authorized Representative: Jake Loveland, Business Development Manager. Contractor shall not replace its Authorized Representative, nor shall Contractor use or replace any subcontractors or subconsultants, without City's prior written

consent. The City may terminate this Agreement if Contractor makes any such change or uses or replaces any such subcontractor or subconsultant.”

B. Section 3 is hereby amended to read as follows:

**“3. Compensation.** City shall pay Contractor a fixed amount as set forth in Exhibits “B” and “B-1” attached and incorporated by reference for services performed under this Agreement.”

C. Exhibits.

Exhibit A-1 “Scope of Services”, attached hereto shall supplement Exhibit “A” of the Agreement. Contractor is responsible for completing all tasks identified in Exhibits “A” and “A-1”.

“Exhibit B-1 Compensation attached hereto shall supplement Exhibit “B” of the Agreement. For services performed by Contractor under this Agreement, City shall pay Contractor on a time and expense basis, at the billing rates set forth in Exhibits “B” and “B-1.”

**5. Signatures.** This Amendment may be executed in any number of counterparts, each of which shall be deemed to be an original and all of which taken together shall constitute one instrument. The individuals executing this Amendment represent and warrant that they have the right, power, legal capacity and authority to enter into and to execute this Amendment. This Amendment shall inure to the benefit of and be binding upon the parties and their respective successors and assigns.

**[SIGNATURES ON FOLLOWING PAGE]**

City of Tracy – Amendment No. 1 to General Services Agreement with SC Commercial, LLC, DBA SC Fuels

The Parties agree to the full performance of the terms set forth here.

City of Tracy

SC Commercial, LLC, DBA SC Fuels

\_\_\_\_\_  
By: Nancy D. Young  
Title: Mayor  
Date: \_\_\_\_\_

DocuSigned by:  
*Robert Bollar*  
32F9022F64FF4B0...  
\_\_\_\_\_  
By: Robert Bollar  
Title: Corp Sec  
Date: 2/8/2024 | 8:01 AM PST  
\_\_\_\_\_

Federal Employer ID No. 83-0751205

Attest:

By: \_\_\_\_\_  
Adrianne Richardson, City Clerk

Approved as to form

By: \_\_\_\_\_  
Bijal M. Patel, City Attorney



EXHIBITS:

A-1 Scope of Services

B-1 Compensation

EXHIBIT A-1 - Scope of Work

**Installation of Standard Loaned Equipment from SC Commercial, LLC, DBA SC Fuels:**

- Fuel- 500-GAL DW UL 142 Fuel Cube with 12V Pump and Gen Package
- Monitor

**EXHIBIT B-1 - Compensation**

<b>Standard Equipment</b>	<b>Qty</b>	<b>Monthly Rental Fee</b>
Fuel- 500-GAL DW UL 142 Fuel Cube with 12V Pump and Gen Package	1	\$250.00
Monitor	1	\$15.00

**Monthly Total:                      \$ 265.00**

City of Tracy – General Services Agreement with SC Commercial, LLC, DBA SC Fuels

**CITY OF TRACY  
GENERAL SERVICES AGREEMENT WITH  
SC COMMERCIAL, LLC, DBA SC FUELS**

This General Services Agreement (**Agreement**) is entered into between the City of Tracy, a municipal corporation (**City**), and SC Commercial, LLC, DBA SC Fuels (**Contractor**). City and Contractor are referred to individually as “Party” and collectively as “Parties.”

**Recitals**

**A.** City desires to retain Contractor to provide diesel fuel at 370 W. Arbor Road, Tracy, CA 95376 for four generators with an estimated capacity of 300 gallons each with two active at all times and an additional two backups and spare fuel tank. This location is considered an on-demand mobile fueling operation; and

**B.** After negotiations between the City and Contractor, the Parties have reached an agreement for the performance of services in accordance with the terms set forth in this Agreement.

**C.** This Agreement is being executed pursuant to Resolution No. 2022-121 approved by Tracy City Council on August 16, 2022.

**Now therefore, the Parties mutually agree as follows:**

**1. Scope of Work.** Contractor shall perform the services described in Exhibit “A” attached and incorporated by reference. The services shall be performed by, or under the direct supervision of, Contractor’s Authorized Representative: Jake Loveland, Business Development Manager. Contractor shall not replace its Authorized Representative, nor shall Contractor use or replace any subcontractors or subconsultants City’s prior written consent. A failure to obtain the City’s prior written consent for any change or replacement in personnel or subcontractor may result in the termination of this Agreement.

**2. Time of Performance.** Time is of the essence in the performance of services under this Agreement and the timing requirements set forth shall be strictly adhered to unless otherwise modified in writing in accordance with this Agreement. Contractor shall begin performance, and shall complete all required services no later than the dates set forth in Exhibit “A.” Any services for which times for performance are not specified in this Agreement shall be started and completed by Contractor in a reasonably prompt and timely manner based upon the circumstances and direction communicated to the Contractor. Contractor shall submit all requests for time extensions to the City in writing no later than ten days after the start of the condition which purportedly caused the delay, and not later than the date on which performance is due. City shall grant or deny such requests at its sole discretion.

**2.1 Term.** The term of this Agreement shall begin on July 1, 2023, and end on July 1, 2025. If the City determines that the Contractor has satisfactorily performed all requirements in this agreement, and per recommendation from the Director of Operations & Utilities to the City Manager, the City Manager may extend the Agreement for an additional four (4) years in any combination not to exceed a total agreement length of six (6) years. If all extensions are applied, the ending date of the Agreement will be June 30, 2029.

**3. Compensation.** City shall pay Contractor on a time and expense basis, at the billing rates set forth in Exhibit “B,” attached and incorporated by reference for services performed under this Agreement.

**3.1 Not to Exceed Amount.** Contractor's total compensation under this Agreement shall not exceed \$500,000. Contractor's billing rates shall cover all costs and expenses for Contractor's performance of this Agreement. No work shall be performed by Contractor in excess of the total compensation amount provided in this section without the City's prior written approval.

**3.2 Invoices.** Contractor shall submit monthly invoices to the City that describe the services performed, including times, dates, and names of persons performing the services.

**3.2.1.** Contractor's failure to submit invoices in accordance with these requirements may result in the City rejecting said invoices and thereby delaying payment to Contractor.

**3.3 Payment.** Within 30 days after the City's receipt of invoice, City shall make payment to the Contractor based upon the services described on the invoice and approved by the City.

**4. Indemnification.** Contractor shall, to the fullest extent permitted by law, indemnify, defend (with independent counsel approved by the City), and hold harmless the City from and against any claims arising out of Contractor's performance or failure to comply with obligations under this Agreement, except to the extent caused by the sole, active negligence or willful misconduct of the City.

In this section, "City" means the City, its officials, officers, agents, employees and volunteers; "Contractor" means the Contractor, its employees, agents and subcontractors; "Claims" includes claims, demands, actions, losses, damages, injuries, and liability, direct or indirect (including any and all related costs and expenses) and any allegations of these; and "Arising out of" includes "pertaining to" and "relating to".

The provisions of this section survive completion of the services or the termination of this Agreement, and are not limited by the provisions of Section 5 relating to insurance.

**5. Insurance.** Contractor shall, throughout the duration of this Agreement, maintain insurance to cover Contractor, its agents, representatives, and employees in connection with the performance of services under this Agreement at the minimum levels set forth herein.

**5.1 Commercial General Liability** (with coverage at least as broad as ISO form CG 00 01 01 96) "per occurrence" coverage shall be maintained in an amount not less than \$4,000,000 general aggregate and \$2,000,000 per occurrence for general liability, bodily injury, personal injury, and property damage.

**5.2 Automobile Liability** (with coverage at least as broad as ISO form CA 00 01 07 97, for "any auto") "claims made" coverage shall be maintained in an amount not less than \$1,000,000 per accident for bodily injury and property damage.

**5.3 Workers' Compensation** coverage shall be maintained as required by the State of California.

**5.4 Professional Liability** "claims made" coverage shall be maintained to cover damages that may be the result of errors, omissions, or negligent acts of Contractor in an amount not less than \$1,000,000 per claim.

**5.5 Pollution Liability Insurance**

**5.5.1** Pollution Coverage shall be provided for liability arising out of sudden, accidental and gradual pollution and remediation. The policy limit shall be no less than two million dollars (\$2,000,000) per claim. All activities contemplated in this agreement shall be specifically scheduled on the policy as "covered operations." The policy will be applicable to the work being performed and provide coverage for the delivery of diesel fuel.

**5.5.2** The policy shall be endorsed to include the City, its officers, employees, and agents as insured.

**5.6 Endorsements.** Contractor shall obtain endorsements to the automobile and commercial general liability insurance policies with the following provisions:

**5.6.1** The City (including its elected officials, officers, employees, agents, and volunteers) shall be named as an additional "insured."

**5.6.2** For any claims related to this Agreement, Contractor's coverage shall be primary insurance with respect to the City. Any insurance maintained by the City shall be excess of the Contractor's insurance and shall not contribute with it.

**5.7 Notice of Cancellation.** Contractor shall notify the City if the policy is canceled before the expiration date. For the purpose of this notice requirement, any material change in the policy prior to the expiration shall be considered a cancellation. Contractor shall immediately obtain a replacement policy.

**5.8 Authorized Insurers.** All insurance companies providing coverage to Contractor shall be insurance organizations authorized by the Insurance Commissioner of the State of California to transact the business of insurance in the State of California.

**5.9 Insurance Certificate.** Contractor shall provide evidence of compliance with the insurance requirements listed above by providing a certificate of insurance and endorsements, in a form satisfactory to the City, before the City signs this Agreement.

**5.10 Substitute Certificates.** Contractor shall provide a substitute certificate of insurance no later than 30 days prior to the policy expiration date of any insurance policy required by this Agreement.

**5.11 Contractor's Obligation.** Maintenance of insurance by the Contractor as specified in this Agreement shall in no way be interpreted as relieving the Contractor of any responsibility whatsoever (including indemnity obligations under this Agreement), and the Contractor may carry, at its own expense, such additional insurance as it deems necessary. Failure to provide or maintain any insurance policies or endorsements required herein may result in the City terminating this Agreement.

**6. Termination.** The City may terminate this Agreement by giving ten days' written notice to Contractor. Upon termination, Contractor shall give the City all original documents, including preliminary drafts and supporting documents, prepared by Contractor for this Agreement. The City shall pay Contractor for all services satisfactorily performed in accordance with this Agreement, up to the date notice is given.

**7. Dispute Resolution.** If any dispute arises between the City and Contractor that cannot be settled after engaging in good faith negotiations, City and Contractor agree to resolve the dispute in accordance with the following:

**7.1** Each Party shall designate a senior management or executive level representative to negotiate the dispute;

**7.2** The representatives shall attempt, through good faith negotiations, to resolve the dispute by any means within their authority.

**7.3** If the issue remains unresolved after fifteen (15) days of good faith negotiations, the Parties shall attempt to resolve the disagreement by negotiations between legal counsel. If the aforementioned process fails, the Parties shall resolve any remaining disputes through mediation to expedite the resolution of the dispute.

**7.4** The mediation process shall provide for the selection within fifteen (15) days by both Parties of a disinterested third person as mediator, shall be commenced within thirty (30) days and shall be concluded within fifteen (15) days from the commencement of the mediation.

**7.5** The Parties shall equally bear the costs of any third party in any alternative dispute resolution process.

**7.6** The dispute resolution process is a material condition to this Agreement and must be exhausted prior to either Party initiating legal action. This dispute resolution process is not intended to nor shall be construed to change the time periods for filing a claim or action specified by Government Code §§ 900 et seq.



**8 Labor Code Compliance.** Contractor is aware of the requirements of Chapter 1 of Part 7 of Division 2 of the California Labor Code and applicable regulations which require the payment of prevailing wage rates (§1771, §1774, and §1775); employment of apprentices (§1777.5), certified payroll records (§1776), hours of labor (§1813 and §1815), debarment of contractors and subcontractors (§1777.1) and the performance of other requirements on “public works” and “maintenance” projects. The services being performed under this Agreement are part of a “public works” or “maintenance” project, as defined in the Prevailing Wage Laws, Contractor agrees to fully comply with such Prevailing Wage Laws.

**8.1 Rates.** These prevailing wage rates are on file with the City and are available online at <http://www.dir.ca.gov/DLSR>. Each Contractor and Subcontractor must pay no less than the specified rates to all workers employed to perform the services described herein. The schedule of per diem wages is based upon a working day of eight hours. The rate for holiday and overtime work must be at least time and one-half. Contractor assumes all responsibility for such payments and shall defend, indemnify and hold the City harmless from any and all claims made by the State of California, the Department of Industrial Relations, any subcontractor, any worker, or any other third party.

**8.2 Registration with DIR.** Contractor warrants that it is registered with the Department of Industrial Relations and qualified to perform the services consistent with Labor Code section 1725.5.

**8.3 Monitoring.** This Agreement will be subject to compliance monitoring and enforcement by the DIR, under Labor Code section 1771.4.

**9. Ownership of Work.** All original documents prepared by Contractor for this Agreement, whether complete or in progress, are the property of the City, and shall be given to the City at the completion of Contractor’s services, or upon demand from the City. No such documents shall be revealed or made available by Contractor to any third party without the City’s prior written consent.

**10. Independent Contractor Status.** Contractor is an independent contractor and is solely responsible for the acts of its employees or agents, including any negligent acts or omissions. Contractor is not City’s employee and Contractor shall have no authority, express or implied, to act on behalf of the City as an agent, or to bind the City to any obligation, unless the City provides prior written authorization. Contractor is free to work for other entities while under contract with the City. Contractor, and its agents or employees, are not entitled to City benefits.

**11. Conflicts of Interest.** Contractor (including its employees, agents, and subcontractors) shall not maintain or acquire any direct or indirect interest that conflicts with the performance of this Agreement. If Contractor maintains or acquires such a conflicting interest, the City may terminate any contract (including this Agreement) involving Contractor’s conflicting interest.

**12. Rebates, Kickbacks, or Other Unlawful Consideration.** Contractor warrants that this Agreement was not obtained or secured through rebates, kickbacks, or other unlawful consideration either promised or paid to any City official or employee. For breach of this warranty, City shall have the right, in its sole discretion, to terminate this Agreement without liability; to pay only for the value of the work actually performed; or to deduct from the contract price; or otherwise recover the full amount of such rebate, kickback, or other unlawful consideration.

**13. Notices.** All notices, demands, or other communications which this Agreement contemplates or authorizes shall be in writing and shall be personally delivered or mailed to the other party to the addresses listed below. Communications shall be deemed to have been given and received on the first to occur of: (1) actual receipt at the address designated below, or (2) three working days after the deposit in the United States Mail of registered or certified mail, sent to the address designated below.

To City:

Operations and Utilities Department  
Attn: James Jackson  
520 N. Tracy Blvd  
Tracy, CA 95376

To Contractor:

SC Fuels  
Attn: Shawn Shears  
237 E. Whitmore Avenue  
Modesto, CA 95358

With a copy to:  
City Attorney  
333 Civic Center Plaza  
Tracy, CA 95376

**14. Miscellaneous.**

**14.1 Standard of Care.** Unless otherwise specified in this Agreement, the standard of care applicable to Contractor's services will be the degree of skill and diligence ordinarily used by reputable professionals performing in the same or similar time and locality, and under the same or similar circumstances.

**14.2 Amendments.** This Agreement may not be modified orally or in any manner other than by an agreement in writing signed by both Parties.

**14.3 Waivers.** Waiver of a breach or default under this Agreement shall not constitute a continuing waiver or a waiver of a subsequent breach of the same or any other provision of this Agreement.

**14.4 Assignment and Delegation.** Contractor may not assign, transfer or delegate this Agreement or any portion of it without the City's written consent. Any attempt to do so will be void. City's consent to one assignment shall not be deemed to be a consent to any subsequent assignment.

**14.5 Jurisdiction and Venue.** The interpretation, validity, and enforcement of the Agreement shall be governed by and construed under the laws of the State of California. Any suit, claim, or legal proceeding of any kind related to this Agreement shall be filed and heard in a court of competent jurisdiction in the County of San Joaquin.

**14.6 Compliance with the Law.** Contractor shall comply with all applicable local, state, and federal laws, whether or not those laws are expressly stated in this Agreement.

**14.6.1 Hazardous Materials.** Contractor is responsible for all costs of clean up and/or removal of hazardous and toxic substances spilled as a result of performing their services.

**14.6.2 Non-discrimination.** Contractor represents and warrants that it is an equal opportunity employer and it shall not discriminate against any subcontractor, employee or applicant for employment because of race, religion, color, national origin, handicap, ancestry, sex or age. Contractor shall also comply with all applicable anti-discrimination federal and state laws, including but not limited to, the California Fair Employment and Housing Act (Gov. Code 12990 (a-f) et seq.).

**14.7 Business Entity Status.** Contractor is responsible for filing all required documents and/or forms with the California Secretary of State and meeting all requirements of the Franchise Tax Board, to the extent such requirements apply to Contractor. By entering into this Agreement, Contractor represents that it is not a suspended corporation. If Contractor is a suspended corporation at the time it enters this Agreement, City may take steps to have this Agreement declared voidable.

**14.8 Business License.** Before the City signs this Agreement, Contractor shall obtain a City of Tracy Business License. Contractor shall maintain an active City of Tracy Business License during the term of this Agreement.

**14.9 Successors and Assigns.** This Agreement shall inure to the benefit of and be binding upon the Parties hereto and their respective successors and assigns.



**14.10 Construction of Agreement.** Each Party hereto has had an equivalent opportunity to participate in the drafting of this Agreement and/or to consult with legal counsel. Therefore, the usual construction of an agreement against the drafting Party shall not apply hereto.

**14.11 Severability.** If a term of this Agreement is held invalid by a court of competent jurisdiction, the Agreement shall be construed as not containing that term, and the remainder of this Agreement shall remain in effect.

**14.12 Controlling Provisions.** In the case of any conflict between the terms of this Agreement and the Exhibits hereto, and Contractor's proposal (if any), the Agreement shall control. In the case of any conflict between the Exhibits hereto and the Contractor's proposal (if any), the Exhibits shall control.

**14.13 Entire Agreement.** This Agreement and the attached Exhibits comprise the entire integrated understanding between the Parties concerning the services to be performed. This Agreement supersedes all prior negotiations, representations or agreements. All exhibits attached hereto are incorporated by reference herein.

**15. Signatures.** The individuals executing this Agreement on behalf of Contractor represent and warrant that they have the right, power, legal capacity and authority to enter into and to execute this Agreement on behalf of Contractor.

**[SIGNATURES ON FOLLOWING PAGE]**

The Parties agree to the full performance of the terms set forth here.

City of Tracy

  
By: Nancy D. Young  
Title: Mayor  
Date: 9-15-2023

SC Commercial, LLC, DBA SC Fuels

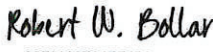
  
By: Robert W. Bollar  
Title: Corporate Secretary and Vice President  
Date: 7/14/2023

Federal Employer Tax ID No. 83-0751205

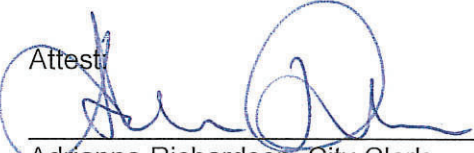
Attest:  
  
Adrienne Richardson, City Clerk

Approved as to form:

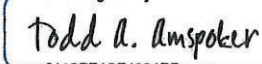
DocuSigned by:  
  
For Bijal M. Patel, City Attorney

Exhibits:

- A Scope of Work, including personnel and time of performance (See Agreement sections 1 and 2.)
- B Compensation (See Agreement section 3.)

EXHIBIT A – SCOPE OF SERVICES

FOR

DIESEL FUEL SUPPLIER FOR TEMPORARY EMERGENCY SHELTER

1. OVERVIEW:

The Contractor shall have a diesel fuel supply Agreement which shall assure the continuous supply of diesel fuel during the Agreement period. Contractor may be required to furnish information supporting their ability to supply, without major interruption, the products covered in this Scope of Services.

2. DELIVERY REQUIREMENTS:

2.1. Product shall be delivered as ordered by Director of Operations & Utilities or their designee.

2.2. The City reserves the right to add or remove delivery locations as required by its operations. Contractor shall not charge a zone price differential for delivery.

2.3. If an order is placed for a truck and trailer quantity to be delivered and the Contractor elects to make that delivery in a vehicle of lesser capacity, the Contractor shall not charge more than the truck and trailer prices.

2.4. All deliveries shall be made in a metered truck or temperature correction adjustments to 60° F shall be made.

2.5. All deliveries shall be made within 24 - 36 hours after order has been placed. Orders shall be placed by authorized e-mail or phone. If a phone order is placed, a follow-up email will be sent to Contractors Authorized Representative.

3. DELIVERY LOCATION & TIMES:

3.1. Location:

City of Tracy Temporary Emergency Shelter  
370 W. Arbor Rd  
Tracy, CA 95376

3.2. Times:

Fuel shall be delivered to the site Monday through Friday, between 7:00 AM to 4:00 PM of each week. The City reserves the right to place additional orders for fuel delivery at any time.

The City may require periodic fuel delivery at other locations that are to be determined as necessary.

4. FUEL:

4.1. Quantity:

There shall be no guarantee as to actual quantities required during the period of the Agreement. The City's annual diesel fuel usage is estimated to be 48,000 gallons.

4.2. Quality:

Diesel fuel shall be Dyed CARB Ultra Low Sulfur Diesel, if unavailable, CARB Ultra Low Sulfur Diesel No. 2, and then Renewable (R99) CARB Ultra Low Sulfur Diesel No. 2 is acceptable and shall comply with all CARB requirements. It shall meet or exceed the requirements of the latest edition of ASTM D975 and shall meet the sulfur content and the aromatic content in California Code of Regulation, Title 13, section 2281 and section 2282. Renewable diesel should be treated the same as conventional CARB diesel for all purposes, including storage in underground storage tanks (USTs).

Contractor shall be liable for any and all damages to facilities (including tank, fuel lines, pumps, and dispensers), vehicles, and fuel in storage, which may occur as the result of contaminated fuel or fuel not in compliance with specification.

4.3. Fuel Spills

Contractor shall be responsible for any damage or violations of law caused by any fuel spill during the delivery process. Drivers are to report any spill and the Contractor shall pay City for any costs incurred in the cleanup of any spill.

5. PRICE VERIFICATION:

During the Agreement period, the Contractor will be required to provide price verification. This may be supplied in the form of rack prices in effect at time of delivery and/or copy of Contractor's Rack Supplier invoices that show prices paid for product delivered. The Contractor agrees to make available at their office, at reasonable times during the period of the Agreement, any of the above records for inspection or audit by an authorized representative of the City.

6. SUBCONTRACTORS:

Contractor shall not use subcontractors without the prior written approval of the City of Tracy. Any contract resulting from this bid and any amendments or supplements thereto shall not be assignable by the Contractor either voluntarily or by operation of law without the written approval of the City and shall not become an asset in any bankruptcy receivership or guardianship proceeding. Such contract shall extend to and be binding upon and insure to the benefits of the heirs, executors, administrators, successors, and assign of the respective parties hereto.

7. PERMITS:

Contractor is required to obtain all applicable Federal, State, and local permits include but not limited to an On-Demand Mobile Fueling Operation.

EXHIBIT B - COMPENSATION

**SCHEDULE OF PRICES**

Based on Oil Price Information Service (OPIS) Stockton Daily Rack Average

***\*Bid evaluated on lowest markup***

**Dyed CARB Ultra Low Sulfur Diesel**

Price Per Gallon over OPIS Stockton Daily Rack Rate
\$2.00

**TRACY CITY COUNCIL**

**RESOLUTION NO. \_\_\_\_\_**

---

**APPROVING AMENDMENT NO. 1 TO THE GENERAL SERVICES AGREEMENT WITH SC COMMERCIAL LLC, DBA SC FUELS AT THE TEMPORARY EMERGENCY HOUSING FACILITY, CIP 71112, AT 370 ARBOR AVENUE, TO AMEND THE SCOPE OF WORK TO INCLUDE THE INSTALLATION AND RENTAL OF A 500-GALLON AUXILIARY FUEL TANK FOR GENERATOR #3 FOR A MONTHLY RENTAL AND MONITORING FEE OF \$265.**

**WHEREAS**, the City of Tracy purchases fuel to operate generators located at 370 W. Arbor Avenue, Tracy, to provide power to the City's Temporary Emergency Housing Facility, City Capital Improvement Project (CIP) No. 71112 (Project Site); and

**WHEREAS**, the City requires on-demand mobile fueling of diesel fuel for four generators with two generators active at all times at the Project Site; and

**WHEREAS**, on August 15, 2023, City Council adopted Resolution No. 2023-143 approving a General Services Agreement (GSA) with SC Commercial, LLC dba SC Fuels (Contractor), to provide a two-year general services agreement with SC Commercial, LLC dba SC Fuels, in a not to exceed amount of \$500,000, for on-demand mobile fueling of diesel fuel at the Project Site; and

**WHEREAS**, after entering into the Agreement with Contractor, the opening of the additional dorms at the Project Site, has caused an increase in demand for power and in turn, fuel; and

**WHEREAS**, the amendment to the General Services Agreement (Agreement) with SC Commercial, LLC dba SC Fuels (Contractor) attached hereto as Attachment 1 is required modify the original scope of work to include installation of a 500-gallon auxiliary fuel tank to prevent loss of power until the permanent power is installed at the Project Site; and

**WHEREAS**, the Contractor will install a 500-gallon auxiliary fuel tank for generator #3 and prevent loss of power due to the fuel running out and the rental of the auxiliary fuel tank will eliminate the need for an additional day of fuel delivery; and

**WHEREAS**, the Amendment will: 1) modify the original scope of work to include installation and rental of a 500-gallon auxiliary fuel tank for generator #3 to prevent loss of power due to the fuel running out and eliminate the need for an additional day of fuel delivery, and 2) include the monthly rental fee of \$250 for the auxiliary tank and additional monthly monitoring fee of \$15 for a total of \$265 per month; and

**WHEREAS**, the total compensation under the Amendment will include the amounts as set forth in Exhibits “B” and “B-1” of the Amendment; Upon approval of this item, the City will pay the Contractor the amount stated in Exhibit B-1 of the Amendment; and

**WHEREAS**, the Amendment does not modify the original not-to-exceed amount of \$500,000 is unchanged; and

**WHEREAS**, the Tracy Homelessness Advisory Committee heard this item on March 21, 2024 and recommended that the City Council adopt the proposed Resolution;

**NOW THEREFORE**, be it

**RESOLVED:** That the City Council for the City of Tracy hereby finds the actions approved by this resolution exempt from California Environmental Quality Act (CEQA) pursuant to Government Code section 8698.4 as provided for homeless shelters; and be it further

**RESOLVED:** That the City Council for the City of Tracy hereby approves Amendment No. 1 to the General Services Agreement with SC Commercial LLC dba SC Fuels at the Temporary Emergency Housing Facility, CIP 71112, at 370 Arbor Avenue, attached hereto as Attachment 1, to amend the scope of work to include the installation and rental of a 500-gallon auxiliary fuel tank for generator #3 and for a monthly rental and monitoring fee of \$265; and be it further

**RESOLVED:** That the City Council hereby approves Amendment No. 1 to the General Services Agreement with SC Commercial LLC dba SC Fuels at the Temporary Emergency Housing Facility, CIP 71112, at 370 Arbor Avenue, attached hereto as Attachment 1, and approves its execution, upon approval as to form by the City Attorney.

\*\*\*\*\*

The foregoing Resolution 2024-\_\_\_\_\_ was adopted by the City Council on March 19, 2024, by the following vote:

AYES: COUNCIL MEMBERS:  
NOES: COUNCIL MEMBERS:  
ABSENT: COUNCIL MEMBERS:  
ABSTENTION: COUNCIL MEMBERS:

\_\_\_\_\_  
NANCY D. YOUNG  
Mayor of the City of Tracy, California

ATTEST: \_\_\_\_\_  
ADRIANNE RICHARDSON  
City Clerk and Clerk of the Council of the  
City of Tracy, California

Attachments:

- (1) Amendment No.1 to GSA with SC Commercial, LLC dba SC Fuels



Agenda Item 3.C

RECOMMENDATION

**Staff recommends that the Tracy Homelessness Advisory Committee recommend that the City Council adopt a Resolution (1) determining that compliance with the standard procurement process is not in the best interest of the City pursuant to California Public Contract Code Section 20301 and Tracy Municipal Code Section 2.20.180(b)(4) for entering into a two agreements with PowerGen, Inc. for the rental and maintenance of diesel generators required at the Temporary Emergency Housing Facility; (2) approving an interim General Services Agreement with PowerGen, Inc. for nine (9) months effective July 1, 2023 through March 31, 2024 with a not-to exceed amount to \$617,539.47; (3) approving a new General Services Agreement with PowerGen, Inc. with a not to exceed amount of \$657,253.70 with an initial term from April 1, 2024 through June 30, 2025; and (4) authorizing the City Manager to extend the Agreement up to one additional year, subject to the not-to-exceed amount.**

EXECUTIVE SUMMARY

In 2022, City Council Resolution No. 2022-162 authorized the General Services Agreement with PowerGen, Inc., for the provision of electrical generators and fuel tanks at the Temporary Emergency Housing Facility located at 370 Arbor Road in Tracy (Project Site), from November 1, 2022 to June 30, 2023. Although that agreement expired by its terms on June 30, 2023, PowerGen, Inc. (PowerGen) has continued to perform under the original Agreement at the request of the City, and the City has continued to pay PowerGen for those services on a monthly basis. While the City is currently working diligently to procure electrical equipment required for a permanent power supply, staff determined there is a need to extend these temporary services through June 30, 2025 and possibly beyond in order to keep the facility running.

In conjunction with interim general services agreement to capture the period between July 1, 2023 and March 31, 2024, staff recommends entering into a new agreement with PowerGen at lower rates to extend services through 2025. In lieu of a greater extension of the original agreement, in effort to promote transparency, comply with public bidding requirements, and reduce unnecessary costs, over the last month, staff revisited and surveyed lower-cost alternatives and requested informal bids from two other vendors to provide this temporary power supply service. However, staff was able to work with PowerGen to negotiate the lowest monthly rate for the rentals of the generators that are already installed on-site. As a result, staff is proposing a new agreement with PowerGen, Inc. through June 30, 2025 with an option to extend for an additional 12 months.

BACKGROUND AND LEGISLATIVE HISTORY

On November 1, 2022, the City Council adopted Resolution No. 2023-162 ratifying various procurement contracts for goods and general services executed by the City Manager to implement interim housing solutions to address the declared shelter crisis, including to accommodate the electrical needs of the modulars and custom containers at the Project Site. This was due to continued construction delays for Phase II of the project which include the

power supply switch gears for both the north and south end of the property. On February 21, 2023, the City entered into a General Services Agreement (GSA) with PowerGen pursuant to Resolution No. 2022-162, to provide the rental and maintenance of diesel generators, supplies, and a tank at the Project Site for the period of October 10, 2022 through June 30, 2023.

The term of the GSA expired on June 30, 2023; however, the City has not formally terminated the GSA due to the ongoing need to temporarily provide the electrical needs of the modulators and custom containers at the site for Phase III and Phase IV and has continued to receive services from PowerGen on a monthly basis. Because that agreement expired, an interim agreement is required to bridge the time between expiration and the commencement of the new agreement presently proposed.

### ANALYSIS

Staff has been working for months to procure and establish permanent power supply at the Project Site. On July 5, 2023, the City Council awarded two separate contracts (Resos No. 2023-131 and No. 2023-132) with DV Electric for CIP 71112 Main Power Supply Project for the Project Site. However, on January 16, 2024, Council rescinded both of these resolutions, as the contractor (DV Electric) was non-responsive and not responsible. As a result, staff is still in the process of procuring alternative permanent power supply at the Project Site. The timetable for installation of the permanent power supply is contingent upon procuring "switchgear" electrical components from a separate supplier.

While staff is preparing permanent solutions, there continues to be a need for temporary power at the Project Site.

Tracy Municipal Code Section 2.20.180 (b)(4) states that exceptions to standard procurement procedures is allowable "When, in the determination of the City Council, compliance with the procedure is not in the best interest of the City for those commodities, equipment, or general services, the costs of which equal or exceed Fifty Thousand and no/100ths (\$50,000.00) Dollars."

California Public Contract Code Section 20301(a) states: The purchase of all supplies, equipment, and materials, when the expenditure required exceeds one hundred fifty thousand dollars (\$150,000), shall be by contract let to the lowest responsible bidder, or, in the authority's discretion, to the responsible bidder who submitted a proposal that provides the best value to the authority on the basis of the factors identified in the solicitation. "Best value" means the overall combination of quality, price, and other elements of a proposal that, when considered together, provide the greatest overall benefit in response to the requirements described in the solicitation documents.

Staff contacted other generator suppliers for quotes to provide the same generators and maintenance. In this process, it was determined that using the existing generators and infrastructure to connect the power to the shelter was in the best interest of the City pursuant to Tracy Municipal Code Section 2.20.180 (b)(4) and California Public Contract Code Section 20301(a). In the instance where the City would choose another vendor, PowerGen would be required to remove their equipment and another vendor would be required to install new generators. By doing this, it was highly likely that the shelter would be without power for multiple days. Staff worked with PowerGen to negotiate a lower monthly rental rate that was

comparable to the other quotes. The cost of installing the new generators would have been an added cost to the City.

Staff recommends continuing the rentals of the generators and fuel tanks through PowerGen, at the Project Site to continue to temporarily provide the electrical needs of the modulars and custom containers at the site for Phase III and Phase IV, until the permanent electricity is installed as part of the Phase II-Site Improvements. This agreement includes an option to extend the contract one year extension to provide staff flexibility to use the generators in the event the new power supply is not installed.

Fuel for the generators is being provided under an agreement with another vendor and is no longer supplied by PowerGen.

Staff recommends two agreements to memorialize and extend PowerGen services through 2025:

- (1) An interim General Services Agreement effectively extending the terms of the original agreement with PowerGen that expired on June 30, 2023 to March 31, 2024; and
- (2) A new General Services Agreement at reduced rates, commencing April 1, 2024, for an initial term expiring June 30, 2025, with an administrative option to extend if permanent power has yet to be installed at that time.

#### FISCAL IMPACT

Funding for the first term of the agreement is funded as part of the existing Homeless Services Operating Budget. This available budget is comprised of funding from the General Fund and grants. The second-year term, July 1, 2024 through June 30, 2025 will be included with the FY24-25 Homeless Services General Fund Operating budget.

#### CEQA DETERMINATION

A Notice of Exemption was issued on October 16, 2020, for the Temporary Emergency Housing site at 500 Arbor Avenue in accordance with Government Code sections 65660-65662 for Low Barrier navigation Centers and Section 15269(c) of the CEQA Guidelines (14 Cal. Code Regs. 15269(c) for Emergency Projects. No environmental impacts beyond those already analyzed for the CIP exist; accordingly, no further CEQA analysis is needed.

#### STRATEGIC PLAN

This agenda item supports the Public Safety Strategic Priority and implements the adopted Homelessness Strategic Plan.

#### ACTION REQUESTED OF THE CITY COUNCIL

Staff recommends that the Tracy Homelessness Advisory Committee recommend that the City Council adopt a Resolution (1) determining that compliance with the standard procurement process is not in the best interest of the City pursuant to California Public Contract Code Section 20301 and Tracy Municipal Code Section 2.20.180(b)(4) for entering into a two agreements with PowerGen, Inc. for the rental and maintenance of diesel generators required at the Temporary Emergency Housing Facility; (2) approving an interim General Services Agreement with

PowerGen, Inc. for nine (9) months effective July 1, 2023 through March 31, 2024 with a not-to-exceed amount to \$617,539.47; (3) approving a new General Services Agreement with PowerGen, Inc. with a not to exceed amount of \$657,253.70 with an initial term from April 1, 2024 through June 30, 2025; and (4) authorizing the City Manager to extend the Agreement up to one additional year, subject to the not-to-exceed amount.

Prepared by: Brian MacDonald, Interim Director of Operations and Utilities

Reviewed by: Sara Cowell, Director of Finance  
Bijal Patel, City Attorney  
Kimberly Murdaugh, Interim Assistant City Manager

Approved by: Midori Lichtwardt, City Manager

ATTACHMENTS:

Attachment A – Interim GSA PowerGen, Inc. (July 1, 2023 through March 31, 2024)  
Attachment B – PowerGen, Inc. (July 1, 2023 through March 31, 2024)  
Attachment C – GSA PowerGen, Inc. (Executed in 2022) and Resolution No. 2022-162

**CITY OF TRACY**  
**INTERIM GENERAL SERVICES AGREEMENT WITH**  
*PowerGen, Inc.*

This Interim General Services Agreement (“Agreement”) is made effective July 1, 2023 (“Effective Date”) by and between the City of Tracy, a municipal corporation (“City”), and PowerGen, Inc., a California corporation (“Contractor”). City and Contractor are referred to individually as “Party” and collectively as “Parties.”

**Recitals**

- A.** City desires to enter into this Agreement with Contractor for Contractor to provide the Temporary Emergency Housing Facility located at 370 W. Arbor Avenue, Tracy, CA 95304 (Project Site) with the rental of diesel generators and supplies (as further described herein and in Exhibit A, Project or Services).
- B.** In December of 2022, Phase III of the Project Site was opened, housing up to 48 individuals in leased modular structures. Additionally, Phase IV-Custom Containers was opened in December of 2023, providing housing for an additional 38 individuals.

City Council Resolution No. 2022-162 authorized and the Parties executed the General Services Agreement with PowerGen, Inc., for the provision of electrical generators and fuel tanks at the Project Site from November 1, 2022 to June 30, 2023. Phase III and Phase IV are both being powered by the generators due to the lack of permanent power to the site. Since June 30, 2023, PowerGen, Inc. has continued to perform under the original Agreement at the request of the City.

- C.** The Parties intend to now memorialize that agreement for the exchange of goods and services between July 1, 2023 and March 31, 2024, under the same terms and conditions of the General Services Agreement that expired by its terms on June 30, 2023.
- D.** In January of 2024, City Staff conducted a review and analysis of the Project Site needs for power supply, performed an informal bidding process to analyze alternatives, contacted has requested informal bids from two other vendors to provide this service, and worked with PowerGen for a proposal of lower cost for the same services provided. Staff determined continuing the contractual relationship with PowerGen was in the best interest of the City considering comparable cost of services and cost of transitioning power supply and equipment at a homeless shelter to a different vendor.
- E.** Pursuant to Tracy Municipal Code Section 2.20.180(b)(4), for the foregoing reasons the City Council determined that strict compliance with the standard procurement process is not in the best interest of the City with regard to this Agreement.
- F.** After negotiations between the City and Contractor, the Parties have reached an agreement for the performance of the Services in accordance with the terms set forth in this Agreement.
- G.** This Agreement is being executed pursuant to Tracy Municipal Code section 2.20.080 and pursuant to Resolution No. \_\_\_\_\_ which was adopted by the City Council for the City of Tracy on \_\_\_\_\_.

**Now therefore, the Parties mutually agree as follows:**

**1. Scope of Work.** At the direction of the City, Contractor shall perform the Services and complete the Project, which includes, but is not limited to, the services described in Exhibit "A" attached hereto and incorporated herein by this reference. The Services shall be performed by, or under the direct supervision of, Contractor's Authorized Representative: Mike Quedens. Contractor shall not replace its Authorized Representative, nor shall Contractor use or replace any subcontractors or subconsultants, without City's prior written consent. The City may terminate this Agreement if Contractor makes any such change or replacement or uses any unapproved subcontractor or subconsultant.

**2. Time of Performance.** Time is of the essence in the performance of Services under this Agreement and the timing requirements set forth shall be strictly adhered to unless otherwise modified in writing in accordance with this Agreement. Any Services for which times for performance are not specified in this Agreement shall be started and completed by Contractor in a reasonably prompt and timely manner based upon the circumstances and direction communicated to the Contractor. Contractor shall submit all requests for time extensions to the City in writing no later than ten days after the start of the condition which purportedly caused the delay, and not later than the date on which performance is due. The City may grant or deny such requests in its sole and absolute discretion.

**2.1 Term.** The term of this Agreement shall begin July 1, 2023 and expire on March 31, 2024, unless terminated in accordance with Section 6.

**3. Compensation.** City shall pay Contractor on a time and expense basis for Services performed under this Agreement at the billing rates set forth in Exhibit "B," which is attached hereto and incorporated herein by this reference.

**3.1 Not to Exceed Amount.** Contractor's total compensation under this Agreement shall not exceed \$617,539.47 . It is understood and agreed that Contractor may not receive compensation up to this amount, and Contractor's total compensation under this Agreement will depend on the Services ultimately provided by Contractor. Notwithstanding anything contained herein to the contrary, the payment of any funds under this Agreement shall be subject to the City of Tracy's appropriation of funds for the Services. This Agreement shall terminate in the event that such funds are not appropriated. It is understood and agreed that Contractor may not receive compensation up to the "not-to-exceed" amount (or any other amount), and Contractor's total compensation under this Agreement will depend on the scope of the Services requested and approved by the City. Contractor's billing rates shall cover all costs and expenses for Contractor's performance of this Agreement. No work shall be performed by Contractor in excess of the "not-to-exceed" amount provided in this section without the City's prior written approval.

**3.2 Invoices.** Contractor shall submit monthly invoices to the City that describe in detail satisfactory to the City the services performed, including times, dates, and names of persons performing the services.

**3.2.1.** Contractor's failure to submit invoices in accordance with these requirements may result in the City rejecting said invoices and thereby delaying payment to Contractor.

**3.3 Payment.** Within 30 days after the City's receipt of invoice, City shall make payment to the Contractor based upon the services described on the invoice and approved by the City.

**3.3.1.** The acceptance by Contractor of the final payment made under this Agreement shall constitute a release of City from all claims and liabilities for compensation to Contractor for anything completed, finished or relating to Contractor's services. Contractor agrees that payment by City shall not constitute nor be deemed a release of the responsibility and liability of Contractor or its employees, subcontractors, agents and subconsultants for the accuracy and competency of

the information provided and/or services performed hereunder, nor shall such payment be deemed to be an assumption of responsibility or liability by City for any defect or error in the Services performed by Contractor, its employees, subcontractors, agents and subconsultants.

**3.3.2.** Contractor agrees to maintain books, accounts, payroll records and other information relating to the performance of Contractor's obligations under the Agreement, which shall adequately and correctly reflect the expenses incurred by the Contractor in the performance of Contractor's work under the Agreement. Such books and records shall be open to inspection and audit by the City during regular business hours for three years after expiration or termination of this Agreement.

**4. Indemnification.** Contractor shall, to the fullest extent permitted by law, indemnify, defend (with independent counsel approved by the City), and hold harmless, and reimburse the City for, any and all liabilities, obligations, losses, damages, injunctions, suits, actions, fines, penalties, claims, demands, administrative and judicial proceedings and order, judgments, remedial action requirements, costs and expenses of every kind or nature, and all costs and expenses incurred in connection therewith, including, without limitation, reasonable attorneys' fees and court costs ("Claims") arising directly or indirectly from or out of (including any and all related costs and expenses), relating or pertaining to or resulting from, in whole or in part, this Agreement; any act, omission, or event relating in any way to Contractor's obligations under this Agreement; and/or Contractor's breach of this Agreement, except to the extent such Claim is caused solely by the active negligence or willful misconduct of the City. In this Section 4, "City" means the City, its officials, officers, agents, employees and volunteers; "Contractor" means the Contractor, its employees, agents and subcontractors.

In the event there is a finding and/or determination that Contractor is not an independent contractor and/or is an employee of City, including but not limited to any such finding and/or determination made by the California Public Employees' Retirement System (CalPERS), the Department of Industrial Relations (DIR), or the Internal Revenue Service (IRS), Contractor shall, to the fullest extent permitted by law, indemnify, defend, and hold harmless the City from and against any all claims relating to or in connection with such a finding and/or determination.

Contractor and City mutually waive consequential damages for claims, disputes, or other matters in question, arising out of or relating to this Agreement. This mutual waiver is applicable, without limitation, to all consequential damages due to either party's termination of this Agreement.

The provisions of this section survive the expiration or the termination of this Agreement and are not limited by the provisions of Section 5 relating to insurance.

**5. Insurance.** Contractor shall, throughout the duration of this Agreement, maintain insurance to cover Contractor, its agents, representatives, and employees in connection with the performance of services under this Agreement at the minimum levels set forth herein.

**5.1 Commercial General Liability** (with coverage at least as broad as ISO form CG 00 01 01 96) "per occurrence" coverage shall be maintained in an amount not less than \$4,000,000 general aggregate and \$2,000,000 per occurrence for general liability, bodily injury, personal injury, and property damage.

**5.2 Automobile Liability** (with coverage at least as broad as ISO form CA 00 01 07 97, for "any auto") "claims made" coverage shall be maintained in an amount not less than \$1,000,000 per accident for bodily injury and property damage.

**5.3 Workers' Compensation** coverage shall be maintained as required by the State of California.

**5.4 Professional Liability** “claims made” coverage shall be maintained to cover damages that may be the result of errors, omissions, or negligent acts of Contractor in an amount not less than \$1,000,000 per claim.

**5.5 Endorsements.** Contractor shall obtain endorsements to the automobile and commercial general liability insurance policies with the following provisions:

**5.5.1** The City (including its elected officials, officers, employees, agents, and volunteers) shall be named as an additional “insured.”

**5.5.2** For any claims related to this Agreement, Contractor’s coverage shall be primary insurance with respect to the City. Any insurance maintained by the City shall be excess of the Contractor’s insurance and shall not contribute with it.

**5.6 Notice of Cancellation.** Contractor shall notify the City if the policy is canceled before the expiration date. For the purpose of this notice requirement, any material change in the policy prior to the expiration shall be considered a cancellation. Contractor shall immediately obtain a replacement policy.

**5.7 Authorized Insurers.** All insurance companies providing coverage to Contractor shall be insurance organizations authorized by the Insurance Commissioner of the State of California to transact the business of insurance in the State of California.

**5.8 Insurance Certificate.** Contractor shall provide evidence of compliance with the insurance requirements listed above by providing a certificate of insurance and endorsements, in a form satisfactory to the City, before the City signs this Agreement, and in any event, within five (5) days of such request.

**5.9 Substitute Certificates.** Contractor shall provide a substitute certificate of insurance no later than 30 days prior to the policy expiration date of any insurance policy required by this Agreement.

**5.10 Contractor’s Obligation.** Maintenance of insurance by the Contractor as specified in this Agreement shall in no way be interpreted as relieving the Contractor of any responsibility whatsoever (including indemnity obligations under this Agreement), and the Contractor may carry, at its own expense, such additional insurance as it deems necessary. Failure to provide or maintain any insurance policies or endorsements required herein may result in the City terminating this Agreement.

**6. Termination.** The City may terminate this Agreement in its sole and absolute discretion by giving ten (10) days’ written notice to Contractor. Within five (5) days of such termination, Contractor shall give the City all original documents relating to the Services in Contractor’s possession or control, including, without limitation, preliminary drafts and supporting documents, and any other documents prepared by Contractor pursuant to this Agreement. The City shall pay Contractor for all Services satisfactorily performed in accordance with this Agreement, up to the date notice is given.

**7. Dispute Resolution.** If any dispute arises between the City and Contractor that cannot be settled after engaging in good faith negotiations, City and Contractor agree to resolve the dispute in accordance with the following:

**7.1** Each Party shall designate a senior management or executive level representative to negotiate the dispute;

**7.2** The representatives shall attempt, through good faith negotiations, to resolve the dispute by any means within their authority.

**7.3** If the issue remains unresolved after fifteen (15) days of good faith negotiations, the Parties shall attempt to resolve the disagreement by negotiations between legal counsel. If the aforementioned process fails, the Parties shall resolve any remaining disputes through mediation to expedite the resolution of the dispute.

**7.4** The mediation process shall provide for the selection within fifteen (15) days by both Parties of a disinterested third person to serve as the mediator, shall be commenced within thirty (30) days of selection of a mediator, and shall be concluded within fifteen (15) days from the commencement of the mediation.



**7.5** The Parties shall equally bear the costs of any third party mediator in any alternative dispute resolution process.

**7.6** The dispute resolution process is a material condition to this Agreement and must be exhausted prior to either Party initiating legal action. . If, for any dispute or claim to which this Section applies, any Party commences an action without first attempting to resolve the matter through the process set forth in this Section, or refuses to comply with this Section after a request has been made, then that Party shall not be entitled to recover attorney fees, even if they would otherwise be available to that party in any such action. This dispute resolution process is not intended to nor shall be construed to change the time periods for filing a claim or action specified by Government Code §§ 900 et seq.

**8 Labor Code Compliance.** Contractor is aware of the requirements of Chapter 1 of Part 7 of Division 2 of the California Labor Code and applicable regulations which require the payment of prevailing wage rates (§1771, §1774, and §1775); employment of apprentices (§1777.5), certified payroll records (§1776), hours of labor (§1813 and §1815), debarment of contractors and subcontractors (§1777.1) and the performance of other requirements on “public works” and “maintenance” projects. The Services being performed under this Agreement are part of a “public works” or “maintenance” project, as defined in the Prevailing Wage Laws, Contractor agrees to fully comply with such Prevailing Wage Laws.

**8.1 Rates.** These prevailing wage rates are on file with the City and are available online at <http://www.dir.ca.gov/DLSR>. Each Contractor and Subcontractor must pay no less than the specified rates to all workers employed to perform the services described herein. The schedule of per diem wages is based upon a working day of eight hours. The rate for holiday and overtime work must be at least time and one-half. Contractor assumes all responsibility for such payments and shall defend, indemnify and hold the City harmless from any and all claims made by the State of California, the Department of Industrial Relations, any subcontractor, any worker, or any other third party.

**8.2 Registration with DIR.** Contractor warrants that it is registered with the Department of Industrial Relations and qualified to perform the services consistent with Labor Code section 1725.5.

**8.3 Monitoring.** This Agreement will be subject to compliance monitoring and enforcement by the DIR, under Labor Code section 1771.4.

**9. Ownership of Work.** All original documents prepared by Contractor for this Agreement, whether complete or in progress, are the property of the City, and shall be given to the City at the completion of Contractor’s Services, or within five (5) days of any demand from the City. No such documents shall be revealed or made available by Contractor to any third party without the City’s prior written consent.

**10. Independent Contractor Status.** Contractor is an independent contractor and is solely responsible for the acts of its employees or agents, including any negligent acts or omissions. Contractor is not City’s employee and Contractor shall have no authority, express or implied, to act on behalf of the City as an agent, or to bind the City to any obligation, unless the City provides prior written authorization. Contractor is free to work for other entities while under contract with the City. Contractor, and its agents or employees, are not entitled to City benefits. Contractor shall be solely responsible for, and shall save the City harmless from, all matters relating to the payment of Contractor’s employees, agents, subcontractors and subconsultants, including compliance with social security requirements, federal and State income tax withholding and all other regulations governing employer-employee relations. The City reserves the right to contract with other firms and/or contractors during the term of this Agreement to provide the City the same or similar services that Contractor is providing to the City under this Agreement. Nothing contained in this Agreement guarantees Contractor a certain amount of work, and the City may, in its sole and absolute discretion, allocate and/or delegate work to Contractor so as to satisfy the City’s needs.

**11. Conflicts of Interest.** Contractor (including its employees, agents, and subcontractors) shall not maintain or acquire any direct or indirect interest that conflicts with the performance of this Agreement. If Contractor maintains or acquires such a conflicting interest, the City may terminate any contract (including this Agreement) involving Contractor's conflicting interest.

**12. Rebates, Kickbacks, or Other Unlawful Consideration.** Contractor warrants that this Agreement was not obtained or secured through rebates, kickbacks, or other unlawful consideration either promised or paid to any City official or employee. For any breach of this warranty, City shall have the right, in its sole discretion, to terminate this Agreement without liability; to pay only for the value of the work actually performed; or to deduct from the contract price the value of the rebate, kickback, or other unlawful consideration; or otherwise recover the full amount of such rebate, kickback, or other unlawful consideration.

**13. Notices.** All notices, demands, or other communications which this Agreement contemplates or authorizes shall be in writing and shall be personally delivered or mailed to the other party to the addresses listed below. Communications shall be deemed to have been given and received on the first to occur of: (1) actual receipt at the address designated below, or (2) three working days after the deposit in the United States Mail of registered or certified mail, sent to the address designated below.

To City:

James Thompson  
Fleet Supervisor-APWA CPF  
City of Tracy  
520 N. Tracy Blvd  
Tracy, CA 95376

With a copy to:  
City Attorney  
333 Civic Center Plaza  
Tracy, CA 95376

To Contractor:

PowerGen, Inc.  
793 S. Tracy Blvd. #307  
Tracy, CA 95376

**14. Miscellaneous.**

**14.1 Standard of Care.** Unless otherwise specified in this Agreement, the standard of care applicable to Contractor's services will be the degree of skill and diligence ordinarily used by reputable professionals performing in the same or similar time and locality, and under the same or similar circumstances.

**14.2 Amendments.** This Agreement may not be modified orally or in any manner other than by an agreement in writing signed by both Parties.

**14.3 Waivers.** Waiver of a breach or default under this Agreement shall not constitute a continuing waiver or a waiver of a subsequent breach of the same or any other provision of this Agreement. No waiver shall be effective unless it is in writing and signed by the waiving party.

**14.4 Assignment and Delegation.** Contractor may not assign, transfer or delegate this Agreement or any portion of it without the City's prior written consent. Any attempt to do so will be void. City's consent to one assignment, transfer or delegation shall not be deemed to be a consent to any subsequent assignment, transfer or delegation.

**14.5 Jurisdiction and Venue.** The interpretation, validity, and enforcement of the Agreement shall be governed by and construed under the laws of the State of California. Any suit, claim, or legal proceeding of any kind related to this Agreement shall be filed and heard in a court of competent jurisdiction in the County of San Joaquin.

**14.6 Compliance with the Law.** Contractor shall comply with all applicable local, state, and federal laws, whether or not those laws are expressly stated in this Agreement.

**14.6.1 Hazardous Materials.** Contractor is responsible for all costs of clean up and/or removal of hazardous and toxic substances spilled as a result of performing their services.

**14.6.2 Non-discrimination.** Contractor represents and warrants that it is an equal opportunity employer and it shall not discriminate against any subcontractor, employee or applicant for employment because of race, religion, color, national origin, handicap, ancestry, sex or age. Contractor shall also comply with all applicable anti-discrimination federal and state laws, including but not limited to, the California Fair Employment and Housing Act (Gov. Code 12990 (a-f) et seq.).

**14.7 Business Entity Status.** Contractor is responsible for filing all required documents and/or forms with the California Secretary of State and meeting all requirements of the Franchise Tax Board, to the extent such requirements apply to Contractor. By entering into this Agreement, Contractor represents that it is not a suspended corporation and that it is authorized to do business in California and in good standing with all agencies having jurisdiction over Contractor. If Contractor is a suspended corporation at the time it enters this Agreement, City may take steps to have this Agreement declared voidable.

**14.8 Business License.** Before the City signs this Agreement, Contractor shall obtain a City of Tracy Business License. Contractor shall maintain an active City of Tracy Business License during the term of this Agreement.

**14.9 Successors and Assigns.** This Agreement shall inure to the benefit of and be binding upon the Parties hereto and their respective successors and assigns.

**14.10 Construction of Agreement.** Each Party hereto has had an equivalent opportunity to participate in the drafting of this Agreement and/or to consult with legal counsel. Therefore, the usual construction of an agreement against the drafting Party shall not apply hereto.

**14.11 Severability.** If a term of this Agreement is held invalid by a court of competent jurisdiction, the Agreement shall be construed as not containing that term, and the remainder of this Agreement shall remain in effect.

**14.12 Controlling Provisions.** In the case of any conflict between the terms of this Agreement and the Exhibits hereto, and Contractor's proposal (if any), the Agreement shall control. In the case of any conflict between the Exhibits hereto and the Contractor's proposal (if any), the Exhibits shall control.

**14.13 Entire Agreement.** This Agreement and the attached Exhibits comprise the entire integrated understanding between the Parties concerning the services to be performed. This Agreement supersedes all prior negotiations, representations or agreements. All exhibits attached hereto are incorporated by reference herein.

**14.14 Counterparts.** City and Contractor agree that this Agreement may be executed in two or more counterparts, each of which shall be deemed an original.

**14.15 Expenses for Enforcement.** Contractor and City agree that the prevailing party's reasonable costs, attorneys' fees and expenses, including investigation fees and expert witness fees, shall be paid by the non-prevailing party in any dispute involving the terms and conditions of this Agreement.

**15. Signatures.** The individuals executing this Agreement on behalf of Contractor represent and warrant that they have the right, power, legal capacity and authority to enter into and to execute this Agreement on behalf of Contractor.

**[SIGNATURES ON FOLLOWING PAGE]**

DRAFT

The Parties agree to the full performance of the foregoing terms.

**City of Tracy**

**PowerGen, Inc.**

\_\_\_\_\_  
By: Nancy D. Young  
Title: Mayor  
Date: \_\_\_\_\_

\_\_\_\_\_  
By: Victor Poley  
Title: Chief Executive Officer  
Date: \_\_\_\_\_

Federal Employer Tax ID No. 81-1050033

Attest:

\_\_\_\_\_  
Adrienne Richardson, City Clerk

\_\_\_\_\_  
By: Julie Poley  
Title: Secretary/Treasurer  
Date: \_\_\_\_\_

Approved as to form:

\_\_\_\_\_  
Bijal M. Patel, City Attorney

Exhibits:

- A Scope of Work
- B Compensation

EXHIBIT A - Scope of Work

Contractor shall supply the following rental equipment for the City of Tracy at 370 W. Arbor Avenue, Tracy, CA 95304.

Rental Equipment:

- 200KW Diesel Generator (2) – Triple Shift
- 200KW Diesel Generator (2) – Single Shift
- 800 AMP Panel with Breaker
- 1200 AMP Panel with Breaker
- 400 Amp Automatic Transfer Switch (2)
- Cable Ramps (16)
- Containment Berms (4)
- Cable and Pigtails

DRAFT



EXHIBIT B - Compensation

Generators and Accessories:

- 200KW Diesel Generator (2) – Triple Shift
- 200KW Diesel Generator (2) – Single Shift
- 800 AMP Panel with Breaker
- 1200 AMP Panel with Breaker
- 400 Amp Automatic Transfer Switch (2)
- Cable Ramps (16)
- Containment Berms (4)
- Cable and Pigtails
  - Monthly Rental Rate: \$61,908.93
  - Tax at 8.25%: \$3,416.82

**Grand Total Monthly Rate: \$67,016.42**

**Projected Rental Period: April 1, 2024 to June 30, 2025**

**Projected NTE: \$617,539.47**

**CITY OF TRACY**  
**GENERAL SERVICES AGREEMENT WITH**  
*PowerGen, Inc. – Temporary Emergency Housing Facility Generator Rentals*

This General Services Agreement (**Agreement**) is entered into between the City of Tracy, a municipal corporation (**City**), and PowerGen, Inc., a California corporation (**Contractor**). City and Contractor are referred to individually as “Party” and collectively as “Parties.”

**Recitals**

- A.** City desires to retain Contractor to provide the Temporary Emergency Housing Facility (TEHF) with the rental of diesel generators, supplies, and a fuel tank; and
- B.** After negotiations between the City and Contractor, the Parties have reached an agreement for the performance of services in accordance with the terms set forth in this Agreement.
- C.** Pursuant to Resolution No. 2022-121, approved by Tracy City Council on August 16<sup>th</sup>, 2022, and Resolution No. 2022-162, approved by Tracy City Council on November 1<sup>st</sup>, 2022, City Council dispensed the procurement requirements for this Agreement under Tracy Municipal Code section 2.20.180, subsection (b)(4), and authorized execution of this Agreement.

**Now therefore, the Parties mutually agree as follows:**

- 1. Scope of Work.** Contractor shall perform the services described in Exhibit “A” attached and incorporated by reference. The services shall be performed by, or under the direct supervision of, Contractor’s Authorized Representative: PowerGen, Inc. Contractor shall not replace its Authorized Representative, nor shall Contractor use or replace any subcontractors or subconsultants, without City’s prior written consent. A failure to obtain the City’s prior written consent for any change or replacement in personnel or subcontractor may result in the termination of this Agreement.
- 2. Time of Performance.** Time is of the essence in the performance of services under this Agreement and the timing requirements set forth shall be strictly adhered to unless otherwise modified in writing in accordance with this Agreement. Any services for which times for performance are not specified in this Agreement shall be started and completed by Contractor in a reasonably prompt and timely manner based upon the circumstances and direction communicated to the Contractor. Contractor shall submit all requests for time extensions to the City in writing no later than ten days after the start of the condition which purportedly caused the delay, and not later than the date on which performance is due. City shall grant or deny such requests at its sole discretion.
  - 2.1 Term.** The term of this Agreement shall begin on October 10<sup>th</sup>, 2022 and end on June 30<sup>th</sup>, 2023, unless terminated in accordance with Section 6.
- 3. Compensation.** City shall pay Contractor on a time and expense basis, at the billing rates set forth in Exhibit “B,” attached and incorporated by reference for services performed under this Agreement.
  - 3.1 Not to Exceed Amount.** Contractor’s total compensation under this Agreement shall not exceed \$559,483.36. Contractor’s billing rates shall cover all costs and expenses for Contractor’s performance of this Agreement. No work shall be performed by Contractor in excess of the total compensation amount provided in this section without the City’s prior written approval.

**3.2 Invoices.** Contractor shall submit monthly invoices to the City that describe the services performed, including times, dates, and names of persons performing the services.

**3.2.1.** Contractor's failure to submit invoices in accordance with these requirements may result in the City rejecting said invoices and thereby delaying payment to Contractor.

**3.3 Payment.** Within 30 days after the City's receipt of invoice, City shall make payment to the Contractor based upon the services described on the invoice and approved by the City.

**4. Indemnification.** Contractor shall, to the fullest extent permitted by law, indemnify, defend (with independent counsel approved by the City), and hold harmless the City from and against any claims arising out of Contractor's performance or failure to comply with obligations under this Agreement, except to the extent caused by the sole, active negligence or willful misconduct of the City.

In this section, "City" means the City, its officials, officers, agents, employees and volunteers; "Contractor" means the Contractor, its employees, agents and subcontractors; "Claims" includes claims, demands, actions, losses, damages, injuries, and liability, direct or indirect (including any and all related costs and expenses) and any allegations of these; and "Arising out of" includes "pertaining to" and "relating to".

The provisions of this section survive completion of the services or the termination of this Agreement, and are not limited by the provisions of Section 5 relating to insurance.

**5. Insurance.** Contractor shall, throughout the duration of this Agreement, maintain insurance to cover Contractor, its agents, representatives, and employees in connection with the performance of services under this Agreement at the minimum levels set forth herein.

**5.1 Commercial General Liability** (with coverage at least as broad as ISO form CG 00 01 01 96) "per occurrence" coverage shall be maintained in an amount not less than \$4,000,000 general aggregate and \$2,000,000 per occurrence for general liability, bodily injury, personal injury, and property damage.

**5.2 Automobile Liability** (with coverage at least as broad as ISO form CA 00 01 07 97, for "any auto") "claims made" coverage shall be maintained in an amount not less than \$1,000,000 per accident for bodily injury and property damage.

**5.3 Workers' Compensation** coverage shall be maintained as required by the State of California.

**5.4 Professional Liability** "claims made" coverage shall be maintained to cover damages that may be the result of errors, omissions, or negligent acts of Contractor in an amount not less than \$1,000,000 per claim.

**5.5 Endorsements.** Contractor shall obtain endorsements to the automobile and commercial general liability insurance policies with the following provisions:

**5.5.1** The City (including its elected officials, officers, employees, agents, and volunteers) shall be named as an additional "insured."

**5.5.2** For any claims related to this Agreement, Contractor's coverage shall be primary insurance with respect to the City. Any insurance maintained by the City shall be excess of the Contractor's insurance and shall not contribute with it.

**5.6 Notice of Cancellation.** Contractor shall notify the City if the policy is canceled before the expiration date. For the purpose of this notice requirement, any material change in the policy prior to the expiration shall be considered a cancellation. Contractor shall immediately obtain a replacement policy.

**5.7 Authorized Insurers.** All insurance companies providing coverage to Contractor shall be insurance organizations authorized by the Insurance Commissioner of the State of California to transact the business of insurance in the State of California.

**5.8 Insurance Certificate.** Contractor shall provide evidence of compliance with the insurance requirements listed above by providing a certificate of insurance and endorsements, in a form satisfactory to the City, before the City signs this Agreement.

**5.9 Substitute Certificates.** Contractor shall provide a substitute certificate of insurance no later than 30 days prior to the policy expiration date of any insurance policy required by this Agreement.

**5.10 Contractor's Obligation.** Maintenance of insurance by the Contractor as specified in this Agreement shall in no way be interpreted as relieving the Contractor of any responsibility whatsoever (including indemnity obligations under this Agreement), and the Contractor may carry, at its own expense, such additional insurance as it deems necessary. Failure to provide or maintain any insurance policies or endorsements required herein may result in the City terminating this Agreement.

**6. Termination.** The City may terminate this Agreement by giving ten days' written notice to Contractor. Upon termination, Contractor shall give the City all original documents, including preliminary drafts and supporting documents, prepared by Contractor for this Agreement. The City shall pay Contractor for all services satisfactorily performed in accordance with this Agreement, up to the date notice is given.

**7. Dispute Resolution.** If any dispute arises between the City and Contractor that cannot be settled after engaging in good faith negotiations, City and Contractor agree to resolve the dispute in accordance with the following:

**7.1** Each Party shall designate a senior management or executive level representative to negotiate the dispute;

**7.2** The representatives shall attempt, through good faith negotiations, to resolve the dispute by any means within their authority.

**7.3** If the issue remains unresolved after fifteen (15) days of good faith negotiations, the Parties shall attempt to resolve the disagreement by negotiations between legal counsel. If the aforementioned process fails, the Parties shall resolve any remaining disputes through mediation to expedite the resolution of the dispute.

**7.4** The mediation process shall provide for the selection within fifteen (15) days by both Parties of a disinterested third person as mediator, shall be commenced within thirty (30) days and shall be concluded within fifteen (15) days from the commencement of the mediation.

**7.5** The Parties shall equally bear the costs of any third party in any alternative dispute resolution process.

**7.6** The dispute resolution process is a material condition to this Agreement and must be exhausted prior to either Party initiating legal action. This dispute resolution process is not intended to nor shall be construed to change the time periods for filing a claim or action specified by Government Code §§ 900 et seq.

**8 Labor Code Compliance.** Contractor is aware of the requirements of Chapter 1 of Part 7 of Division 2 of the California Labor Code and applicable regulations which require the payment of prevailing wage rates (§1771, §1774, and §1775); employment of apprentices (§1777.5), certified payroll records (§1776), hours of labor (§1813 and §1815), debarment of contractors and subcontractors (§1777.1) and the performance of other requirements on "public works" and "maintenance" projects. The services being performed under this Agreement are part of a "public works" or "maintenance" project, as defined in the Prevailing Wage Laws, Contractor agrees to fully comply with such Prevailing Wage Laws.

**8.1 Rates.** These prevailing wage rates are on file with the City and are available online at <http://www.dir.ca.gov/DLSR>. Each Contractor and Subcontractor must pay no less than the specified rates to all workers employed to perform the services described herein. The schedule of per diem wages is based upon a working day of eight hours. The rate for holiday and overtime work must be at least time and one-half. Contractor assumes all responsibility for such payments and shall defend,

indemnify and hold the City harmless from any and all claims made by the State of California, the Department of Industrial Relations, any subcontractor, any worker, or any other third party.

**8.2 Registration with DIR.** Contractor warrants that it is registered with the Department of Industrial Relations and qualified to perform the services consistent with Labor Code section 1725.5.

**8.3 Monitoring.** This Agreement will be subject to compliance monitoring and enforcement by the DIR, under Labor Code section 1771.4.

**9. Ownership of Work.** All original documents prepared by Contractor for this Agreement, whether complete or in progress, are the property of the City, and shall be given to the City at the completion of Contractor's services, or upon demand from the City. No such documents shall be revealed or made available by Contractor to any third party without the City's prior written consent.

**10. Independent Contractor Status.** Contractor is an independent contractor and is solely responsible for the acts of its employees or agents, including any negligent acts or omissions. Contractor is not City's employee and Contractor shall have no authority, express or implied, to act on behalf of the City as an agent, or to bind the City to any obligation, unless the City provides prior written authorization. Contractor is free to work for other entities while under contract with the City. Contractor, and its agents or employees, are not entitled to City benefits.

**11. Conflicts of Interest.** Contractor (including its employees, agents, and subcontractors) shall not maintain or acquire any direct or indirect interest that conflicts with the performance of this Agreement. If Contractor maintains or acquires such a conflicting interest, the City may terminate any contract (including this Agreement) involving Contractor's conflicting interest.

**12. Rebates, Kickbacks, or Other Unlawful Consideration.** Contractor warrants that this Agreement was not obtained or secured through rebates, kickbacks, or other unlawful consideration either promised or paid to any City official or employee. For breach of this warranty, City shall have the right, in its sole discretion, to terminate this Agreement without liability; to pay only for the value of the work actually performed; or to deduct from the contract price; or otherwise recover the full amount of such rebate, kickback, or other unlawful consideration.

**13. Notices.** All notices, demands, or other communications which this Agreement contemplates or authorizes shall be in writing and shall be personally delivered or mailed to the other party to the addresses listed below. Communications shall be deemed to have been given and received on the first to occur of: (1) actual receipt at the address designated below, or (2) three working days after the deposit in the United States Mail of registered or certified mail, sent to the address designated below.

To City:

Karin Schnaider  
Assistant City Manager  
City of Tracy  
333 Civic Center Plaza  
Tracy, CA 95376

With a copy to:  
City Attorney  
333 Civic Center Plaza  
Tracy, CA 95376

To Contractor:

PowerGen, Inc.  
793 S. Tracy Blvd. #307  
Tracy, CA 95376

**14. Miscellaneous.**

**14.1 Standard of Care.** Unless otherwise specified in this Agreement, the standard of care applicable to Contractor's services will be the degree of skill and diligence ordinarily used by reputable professionals performing in the same or similar time and locality, and under the same or similar circumstances.

**14.2 Amendments.** This Agreement may not be modified orally or in any manner other than by an agreement in writing signed by both Parties.

**14.3 Waivers.** Waiver of a breach or default under this Agreement shall not constitute a continuing waiver or a waiver of a subsequent breach of the same or any other provision of this Agreement.

**14.4 Assignment and Delegation.** Contractor may not assign, transfer or delegate this Agreement or any portion of it without the City's written consent. Any attempt to do so will be void. City's consent to one assignment shall not be deemed to be a consent to any subsequent assignment.

**14.5 Jurisdiction and Venue.** The interpretation, validity, and enforcement of the Agreement shall be governed by and construed under the laws of the State of California. Any suit, claim, or legal proceeding of any kind related to this Agreement shall be filed and heard in a court of competent jurisdiction in the County of San Joaquin.

**14.6 Compliance with the Law.** Contractor shall comply with all applicable local, state, and federal laws, whether or not those laws are expressly stated in this Agreement.

**14.6.1 Hazardous Materials.** Contractor is responsible for all costs of clean up and/or removal of hazardous and toxic substances spilled as a result of performing their services.

**14.6.2 Non-discrimination.** Contractor represents and warrants that it is an equal opportunity employer and it shall not discriminate against any subcontractor, employee or applicant for employment because of race, religion, color, national origin, handicap, ancestry, sex or age. Contractor shall also comply with all applicable anti-discrimination federal and state laws, including but not limited to, the California Fair Employment and Housing Act (Gov. Code 12990 (a-f) et seq.).

**14.7 Business Entity Status.** Contractor is responsible for filing all required documents and/or forms with the California Secretary of State and meeting all requirements of the Franchise Tax Board, to the extent such requirements apply to Contractor. By entering into this Agreement,



Contractor represents that it is not a suspended corporation. If Contractor is a suspended corporation at the time it enters this Agreement, City may take steps to have this Agreement declared voidable.

**14.8 Business License.** Before the City signs this Agreement, Contractor shall obtain a City of Tracy Business License. Contractor shall maintain an active City of Tracy Business License during the term of this Agreement.

**14.9 Successors and Assigns.** This Agreement shall inure to the benefit of and be binding upon the Parties hereto and their respective successors and assigns.

**14.10 Construction of Agreement.** Each Party hereto has had an equivalent opportunity to participate in the drafting of this Agreement and/or to consult with legal counsel. Therefore, the usual construction of an agreement against the drafting Party shall not apply hereto.

**14.11 Severability.** If a term of this Agreement is held invalid by a court of competent jurisdiction, the Agreement shall be construed as not containing that term, and the remainder of this Agreement shall remain in effect.

**14.12 Controlling Provisions.** In the case of any conflict between the terms of this Agreement and the Exhibits hereto, and Contractor's proposal (if any), the Agreement shall control. In the case of any conflict between the Exhibits hereto and the Contractor's proposal (if any), the Exhibits shall control.

**14.13 Entire Agreement.** This Agreement and the attached Exhibits comprise the entire integrated understanding between the Parties concerning the services to be performed. This Agreement supersedes all prior negotiations, representations or agreements. All exhibits attached hereto are incorporated by reference herein.

**15. Signatures.** The individuals executing this Agreement on behalf of Contractor represent and warrant that they have the right, power, legal capacity and authority to enter into and to execute this Agreement on behalf of Contractor.

**[SIGNATURES ON FOLLOWING PAGE]**

City of Tracy – General Services Agreement with PowerGen, Inc.

The Parties agree to the full performance of the terms set forth here.

**City of Tracy**

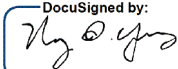
DocuSigned by:  
  
819521B585CB4AC...  
By: Nancy D. Young  
Title: Mayor  
Date: 2/21/2023 | 10:54 AM PST

**PowerGen, Inc.**

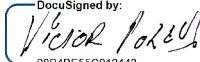
DocuSigned by:  
  
08B4BE55C912443...  
By: Victor Poley  
Title: CEO  
Date: 2/15/2023 | 12:09 PM EST

Federal Employer Tax ID No. 81-1050033

**Attest:**

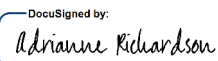
DocuSigned by:  
  
C9C860E26FF741C...  
Adrienne Richardson, City Clerk

DocuSigned by:  
  
345710277CBC488...  
By: Julie Poley  
Title: Secretary/Treasurer  
Date: 2/15/2023 | 9:02 PM PST

**Approved as to form:**

DocuSigned by:  
  
07D8AA113BD04A3...  
Bijal M. Patel, City Attorney

**Exhibits:**

- A Scope of Work, including personnel and time of performance (See Agreement sections 1 and 2.)
- B Compensation (See Agreement section 3.)

## EXHIBIT A - Scope of Work

PowerGen, Inc. will provide, deliver, and pick up the following rentals at 370 Arbor Rd., Tracy, CA 95304:

- Supply - 700-gallon Fuel Tank
- Supply - Cable Ramps (16)
- 20 x 4/0 Male Pig Tails
- 21 x 25' 4/0 Camlock Cable
- 38 x 50' 4/0 Camlock Cable
- 800 Amp Distribution Panel
- 1200 Amp Distribution Panel
- 10' x 18' Containment Berm (4)
- 400 Amp Automatic Transfer Switch (2)
- 200KW Diesel Generator (2) – Single Shift
- 200KW Diesel Generator (2) – Triple Shift

EXHIBIT B - Compensation

**1) 700-gallon Fuel Tank**

- ◆ Material: \$1,200.00 (Monthly Rental Charge)
- ◆ Tax @ 8.25%: \$ 99.00

**Total: \$1,299.00**

**2) Generators and Accessories**

- ◆ **Cable Ramps (16)**
- ◆ **20 x 4/0 Male Pig Tails**
- ◆ **21 x 25' 4/0 Camlock Cable**
- ◆ **38 x 50' 4/0 Camlock Cable**
- ◆ **800 Amp Distribution Panel**
- ◆ **1200 Amp Distribution Panel**
- ◆ **10' x 18' Containment Berm (4)**
- ◆ **400 Amp Automatic Transfer Switch (2)**
- ◆ **200KW Diesel Generator (2) – Single Shift**
- ◆ **200KW Diesel Generator (2) – Triple Shift**
  - ◇ Material: \$61,908.93 (Monthly Rental Charge)
  - ◇ Delivery Charge: \$ 810.00
  - ◇ Pickup Charge: \$ 810.00
  - ◇ Tax @ 8.25%: \$ 5,107.49

**Total: \$68,636.42**

**Grand Total: \$69,935.42 Monthly Rental Charge**  
**Projected Rental Period – November 22' to June 23'**  
**Projected NTE: \$559,483.36**

APPROVED AS TO FORM AND LEGALITY

  
CITY ATTORNEY'S OFFICE

TRACY CITY COUNCIL

RESOLUTION NO. 2022-162

---

**RATIFYING, PURSUANT TO TRACY MUNICIPAL CODE SECTION 2.20.180(B)(1), VARIOUS PROCUREMENT CONTRACTS FOR GOODS AND GENERAL SERVICES EXECUTED BY THE CITY MANAGER TO IMPLEMENT INTERIM HOUSING SOLUTIONS TO ADDRESS THE DECLARED SHELTER CRISIS**

**WHEREAS**, the City of Tracy, like many cities across California, is experiencing a shelter crisis; and

**WHEREAS**, on March 10, 2020, the City Council declared a shelter crisis through the adoption of Resolution 2020-052; and

**WHEREAS**, under the shelter crisis, the City is authorized to provide emergency housing, shelters, bridge housing communities, and other services to the unsheltered; and

**WHEREAS**, on September 1, 2020, the City Council authorized the creation of a Capital Improvement Project for the Temporary Emergency Housing Project on Arbor Avenue, CIP 71112 (Project) to create a safe and dignified facility for residents experiencing homelessness (Facility); and

**WHEREAS**, site work for the Facility is underway, and the City solicited bids for the Project; and

**WHEREAS**, on August 16, 2022, the Council rejected the bid from the sole bidder, Gowan Construction, Inc. and authorized a rebid of this project; and

**WHEREAS**, the continued shelter crisis is resulting in a threat to the safety and health of the unsheltered as well as other residents in the City; and **WHEREAS**, the City desires to provide interim housing solutions until the completion and opening of the City's Facility; and

**WHEREAS**, the solutions will require vendors to implement and operate the interim solutions; and

**WHEREAS**, the solutions may include various interim housing solutions, including procurement of goods and services; and

**WHEREAS**, on August 16, 2022, the City Council approved Resolution 2022-121 and directed the City Manager to take immediate and emergency actions necessary to implement interim housing solutions for Tracy's unsheltered until the completion and opening of the Facility, including negotiating with potential service providers and identifying potential sites for such interim housing solutions; and



**WHEREAS**, pursuant to Tracy Municipal Code Section 2.20.140(b)(6), Resolution 2022-121 dispensed the procurement requirements for professional services for contracts providing interim housing solutions; and

**WHEREAS**, for purchases or general services of \$50,000 or more, Tracy Municipal Code Section 2.20.180 requires that the City follow a formal bidding procedure for the procurement of such goods or general services; and

**WHEREAS**, Tracy Municipal Code Section 2.20.180(b)(1) allows such formal bidding procedures to be dispensed in an emergency, provided that the City Manager reports to the City Council, at the next regular meeting, the reasons justifying why the emergency will not permit a delay resulting from a competitive solicitation for bids and why the action is necessary to respond to the emergency; and

**WHEREAS**, the shelter crisis poses an immediate threat to the health and safety of the unsheltered and surrounding Tracy community, and the City Manager has executed the contracts set forth in Exhibit A, attached hereto, due to this emergency; and

**WHEREAS**, many of the opportunities to provide interim housing solutions would have become unavailable if the City conducted formal bidding procedures;

**WHEREAS**, Government Code section 8698.4 exempts the application of the California Environmental Quality Act (CEQA) to various actions taken by public agencies to implement the construction of a homeless shelter in response to a declared shelter crisis; and

**WHEREAS**, a Notice of Exemption was issued on October 16, 2020 for the Temporary Emergency Housing (Facility) site at 500 Arbor Avenue in accordance with Government Code sections 65660-65662 for Low Barrier navigation Centers and Section 15269(c) of the CEQA Guidelines (14 Cal. Code Regs. 15269(c) for (Emergency Projects); and now therefore be it

**RESOLVED:** That the City Council finds and determines the foregoing recitals to be true and correct and hereby makes them a part of this Resolution; and be it

**FURTHER RESOLVED:** That the City Council hereby ratifies the contracts for procurement of goods and certain general services set forth in Exhibit A that have been executed by the City Manager, pursuant to Tracy Municipal Code section Section 2.20.180(b) (1); ~~and~~ **FURTHER RESOLVED:** That the City Council hereby finds that formal bidding procedures for the above contracts were properly dispensed to due to the declared shelter crisis; and be it

**FURTHER RESOLVED:** the City Council, based on its own independent investigation and judgment, finds that no further analysis under the California Environmental Quality Act (CEQA) for the actions authorized herein because: 1) Government Code section 8698.4 exempts the application of the various actions taken by public agencies to implement the construction of a homeless shelter in response to a declared shelter crisis; 2) the interim solutions taken thus far are in furtherance of and related to the permanent solution that will be implemented, referred to as the Temporary Emergency Housing Project on Arbor Avenue (CIP 71112); 3) A Notice of Exemption was issued on October 16, 2020 for the Temporary Emergency Housing site at 500 Arbor Avenue in accordance with Government Code sections 65660-65662 for Low Barrier navigation Centers and Section 15269(c) of the CEQA

Guidelines (14 Cal. Code Regs. 15269(c) for (Emergency Projects); and 4) No environmental impacts beyond those already analyzed for the CIP exist.

\*\*\*\*\*

The foregoing Resolution 2022-162 was adopted by the Tracy City Council on November 1, 2022, by the following vote:

AYES: COUNCIL MEMBERS: ARRIOLA, BEDOLLA, DAVIS, VARGAS, YOUNG  
NOES: COUNCIL MEMBERS: NONE  
ABSENT: COUNCIL MEMBERS: NONE  
ABSTENTION: COUNCIL MEMBERS: NONE

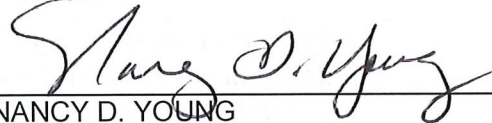

NANCY D. YOUNG  
Mayor of the City of Tracy, California

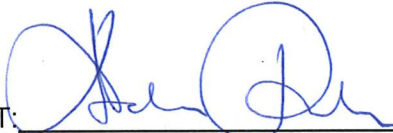

ATTEST:  
ADRIANNE RICHARDSON  
City Clerk and Clerk of the Council of the  
City of Tracy, California

**Exhibit A**  
**SIGNED CONTRACTS PROPOSED FOR CITY COUNCIL RATIFICATION**

<u>Vendor</u>	<u>Summary</u>	<u>FY 2022/23</u>	<u>Not to Exceed Amount</u>
Grade Tech	Change order with contractor to prepare Arbor Road site for modulars and shipping container sleeping quarters; funded by CIP 71112	\$670,000	\$670,000
KPA Group	Change order with engineering firm to prepare Arbor Road site for modulars and shipping container sleeping quarters; funded by CIP 71112	\$68,580	\$68,580
Mobile Modular	Lease of four modulars for non-congregate sleeping quarters (approximately 50 beds) and one Administration Building	\$192,000	\$1,000,000
PowerGen	Rental of Generators for 12 months	\$43,000	\$75,000
PowerGen	Fuel supplied and delivered for 12 months	\$875,000	\$1,250,000
American Bedding	Sleeping quarter furniture (approximately 90 beds)	\$ 65,000	\$65,000
Custom Containers 915 (shipping containers)	Purchase of eight shipping containers for non-congregate sleeping quarters (approximately 40 beds)	\$656,000	\$656,000
Bicsec Security Inc	Fire Alarm System Installation	\$66,738	\$66,738
Jr Wagner Fire Protection Inc	Installation of Fire Sprinklers	\$26,000	\$26,000
United Fence Services	Temporary fencing until permanent fencing installed	\$20,000	\$20,000

**CITY OF TRACY**  
**GENERAL SERVICES AGREEMENT WITH**  
*PowerGen, Inc.*

This General Services Agreement (“Agreement”) is made effective April 1, 2024 (“Effective Date”) by and between the City of Tracy, a municipal corporation (“City”), and PowerGen, Inc., a California corporation (“Contractor”). City and Contractor are referred to individually as “Party” and collectively as “Parties.”

**Recitals**

- A.** City desires to enter into this Agreement with Contractor for Contractor to provide the Temporary Emergency Housing Facility located at 370 W. Arbor Avenue, Tracy, CA 95304 (Project Site) with the rental of diesel generators and supplies (as further described herein and in Exhibit A, Project or Services).
- B.** In December of 2022, Phase III of the Project Site was opened, housing up to 48 individuals in leased modular structures. Additionally, Phase IV-Custom Containers was opened in December of 2023, providing housing for an additional 38 individuals.
- C.** City Council Resolution No. 2022-162 authorized and the Parties executed the General Services Agreement with PowerGen, Inc., for the provision of electrical generators and fuel tanks at the Project Site from November 1, 2022 to June 30, 2023. Phase III and Phase IV are both being powered by the generators due to the lack of permanent power to the site. Since June 30, 2023, PowerGen, Inc. has continued to perform under the original Agreement at the request of the City.

In or about March 2024, the City and Contractor entered into that certain Interim General Services Agreement, made effective July 1, 2023 and expiring March 31, 2024, to memorialize the goods and services exchanged between the Parties for that period, under the same terms and conditions of the original General Services Agreement.

- D.** In January of 2024, City Staff conducted a review and analysis of the Project Site needs for power supply, performed an informal bidding process to analyze alternatives, contacted has requested informal bids from two other vendors to provide this service, and worked with PowerGen for a proposal of lower cost for the same services provided. Staff determined continuing the contractual relationship with PowerGen was in the best interest of the City considering comparable cost of services and cost of transitioning power supply and equipment at a homeless shelter to a different vendor.
- E.** Pursuant to Tracy Municipal Code Section 2.20.180(b)(4), for the foregoing reasons the City Council determined that strict compliance with the standard procurement process is not in the best interest of the City with regard to this Agreement.
- F.** After negotiations between the City and Contractor, the Parties have reached an agreement for the performance of the Services in accordance with the terms set forth in this Agreement.

G. This Agreement is being executed pursuant to Tracy Municipal Code section 2.20.080 and pursuant to Resolution No. \_\_\_\_\_ which was adopted by the City Council for the City of Tracy on \_\_\_\_\_.

**Now therefore, the Parties mutually agree as follows:**

1. **Scope of Work.** At the direction of the City, Contractor shall perform the Services and complete the Project, which includes, but is not limited to, the services described in Exhibit "A" attached hereto and incorporated herein by this reference. The Services shall be performed by, or under the direct supervision of, Contractor's Authorized Representative: Mike Quedens. Contractor shall not replace its Authorized Representative, nor shall Contractor use or replace any subcontractors or subconsultants, without City's prior written consent. The City may terminate this Agreement if Contractor makes any such change or replacement or uses any unapproved subcontractor or subconsultant.

2. **Time of Performance.** Time is of the essence in the performance of Services under this Agreement and the timing requirements set forth shall be strictly adhered to unless otherwise modified in writing in accordance with this Agreement. Any Services for which times for performance are not specified in this Agreement shall be started and completed by Contractor in a reasonably prompt and timely manner based upon the circumstances and direction communicated to the Contractor. Contractor shall submit all requests for time extensions to the City in writing no later than ten days after the start of the condition which purportedly caused the delay, and not later than the date on which performance is due. The City may grant or deny such requests in its sole and absolute discretion.

**2.1 Term.** The term of this Agreement shall begin April 1, 2024 and expire on June 30, 2025, unless terminated in accordance with Section 6. If the City determines that the Contractor has satisfactorily performed all requirements in this agreement, and per recommendation from the Assistant City Manager to the City Manager, the City Manager may extend the Agreement for an additional year (1) year. If all extensions are applied, the ending date of the Agreement will be June 30, 2026.

3. **Compensation.** City shall pay Contractor on a time and expense basis for Services performed under this Agreement at the billing rates set forth in Exhibit "B," which is attached hereto and incorporated herein by this reference.

**3.1 Not to Exceed Amount.** Contractor's total compensation under this Agreement shall not exceed \$657,253.70 . It is understood and agreed that Contractor may not receive compensation up to this amount, and Contractor's total compensation under this Agreement will depend on the Services ultimately provided by Contractor. Notwithstanding anything contained herein to the contrary, the payment of any funds under this Agreement shall be subject to the City of Tracy's appropriation of funds for the Services. This Agreement shall terminate in the event that such funds are not appropriated. It is understood and agreed that Contractor may not receive compensation up to the "not-to-exceed" amount (or any other amount), and Contractor's total compensation under this Agreement will depend on the scope of the Services requested and approved by the City. Contractor's billing rates shall cover all costs and expenses for Contractor's performance of this Agreement. No work shall be performed by Contractor in excess of the "not-to-exceed" amount provided in this section without the City's prior written approval.

**3.2 Invoices.** Contractor shall submit monthly invoices to the City that describe in detail satisfactory to the City the services performed, including times, dates, and names of persons performing the services.

**3.2.1.** Contractor's failure to submit invoices in accordance with these requirements may result in the City rejecting said invoices and thereby delaying payment to Contractor.

**3.3 Payment.** Within 30 days after the City's receipt of invoice, City shall make payment to the Contractor based upon the services described on the invoice and approved by the City.

**3.3.1.** The acceptance by Contractor of the final payment made under this Agreement shall constitute a release of City from all claims and liabilities for compensation to Contractor for anything completed, finished or relating to Contractor's services. Contractor agrees that payment by City shall not constitute nor be deemed a release of the responsibility and liability of Contractor or its employees, subcontractors, agents and subconsultants for the accuracy and competency of the information provided and/or services performed hereunder, nor shall such payment be deemed to be an assumption of responsibility or liability by City for any defect or error in the Services performed by Contractor, its employees, subcontractors, agents and subconsultants.

**3.3.2.** Contractor agrees to maintain books, accounts, payroll records and other information relating to the performance of Contractor's obligations under the Agreement, which shall adequately and correctly reflect the expenses incurred by the Contractor in the performance of Contractor's work under the Agreement. Such books and records shall be open to inspection and audit by the City during regular business hours for three years after expiration or termination of this Agreement.

**4. Indemnification.** Contractor shall, to the fullest extent permitted by law, indemnify, defend (with independent counsel approved by the City), and hold harmless, and reimburse the City for, any and all liabilities, obligations, losses, damages, injunctions, suits, actions, fines, penalties, claims, demands, administrative and judicial proceedings and order, judgments, remedial action requirements, costs and expenses of every kind or nature, and all costs and expenses incurred in connection therewith, including, without limitation, reasonable attorneys' fees and court costs ("Claims") arising directly or indirectly from or out of (including any and all related costs and expenses), relating or pertaining to or resulting from, in whole or in part, this Agreement; any act, omission, or event relating in any way to Contractor's obligations under this Agreement; and/or Contractor's breach of this Agreement, except to the extent such Claim is caused solely by the active negligence or willful misconduct of the City. In this Section 4, "City" means the City, its officials, officers, agents, employees and volunteers; "Contractor" means the Contractor, its employees, agents and subcontractors.

In the event there is a finding and/or determination that Contractor is not an independent contractor and/or is an employee of City, including but not limited to any such finding and/or determination made by the California Public Employees' Retirement System (CalPERS), the Department of Industrial Relations (DIR), or the Internal Revenue Service (IRS), Contractor shall, to the fullest extent permitted by law, indemnify, defend, and hold harmless the City from and against any all claims relating to or in connection with such a finding and/or determination.

Contractor and City mutually waive consequential damages for claims, disputes, or other matters in question, arising out of or relating to this Agreement. This mutual waiver is applicable, without limitation, to all consequential damages due to either party's termination of this Agreement.

The provisions of this section survive the expiration or the termination of this Agreement and are not limited by the provisions of Section 5 relating to insurance.

**5. Insurance.** Contractor shall, throughout the duration of this Agreement, maintain insurance to cover Contractor, its agents, representatives, and employees in connection with the performance of services under this Agreement at the minimum levels set forth herein.

**5.1 Commercial General Liability** (with coverage at least as broad as ISO form CG 00 01 01 96) "per occurrence" coverage shall be maintained in an amount not less than \$4,000,000 general aggregate and \$2,000,000 per occurrence for general liability, bodily injury, personal injury, and property damage.



**5.2 Automobile Liability** (with coverage at least as broad as ISO form CA 00 01 07 97, for “any auto”) “claims made” coverage shall be maintained in an amount not less than \$1,000,000 per accident for bodily injury and property damage.

**5.3 Workers’ Compensation** coverage shall be maintained as required by the State of California.

**5.4 Professional Liability** “claims made” coverage shall be maintained to cover damages that may be the result of errors, omissions, or negligent acts of Contractor in an amount not less than \$1,000,000 per claim.

**5.5 Endorsements.** Contractor shall obtain endorsements to the automobile and commercial general liability insurance policies with the following provisions:

**5.5.1** The City (including its elected officials, officers, employees, agents, and volunteers) shall be named as an additional “insured.”

**5.5.2** For any claims related to this Agreement, Contractor’s coverage shall be primary insurance with respect to the City. Any insurance maintained by the City shall be excess of the Contractor’s insurance and shall not contribute with it.

**5.6 Notice of Cancellation.** Contractor shall notify the City if the policy is canceled before the expiration date. For the purpose of this notice requirement, any material change in the policy prior to the expiration shall be considered a cancellation. Contractor shall immediately obtain a replacement policy.

**5.7 Authorized Insurers.** All insurance companies providing coverage to Contractor shall be insurance organizations authorized by the Insurance Commissioner of the State of California to transact the business of insurance in the State of California.

**5.8 Insurance Certificate.** Contractor shall provide evidence of compliance with the insurance requirements listed above by providing a certificate of insurance and endorsements, in a form satisfactory to the City, before the City signs this Agreement, and in any event, within five (5) days of such request.

**5.9 Substitute Certificates.** Contractor shall provide a substitute certificate of insurance no later than 30 days prior to the policy expiration date of any insurance policy required by this Agreement.

**5.10 Contractor’s Obligation.** Maintenance of insurance by the Contractor as specified in this Agreement shall in no way be interpreted as relieving the Contractor of any responsibility whatsoever (including indemnity obligations under this Agreement), and the Contractor may carry, at its own expense, such additional insurance as it deems necessary. Failure to provide or maintain any insurance policies or endorsements required herein may result in the City terminating this Agreement.

**6. Termination.** The City may terminate this Agreement in its sole and absolute discretion by giving ten (10) days’ written notice to Contractor. Within five (5) days of such termination, Contractor shall give the City all original documents relating to the Services in Contractor’s possession or control, including, without limitation, preliminary drafts and supporting documents, and any other documents prepared by Contractor pursuant to this Agreement. The City shall pay Contractor for all Services satisfactorily performed in accordance with this Agreement, up to the date notice is given.

**7. Dispute Resolution.** If any dispute arises between the City and Contractor that cannot be settled after engaging in good faith negotiations, City and Contractor agree to resolve the dispute in accordance with the following:

**7.1** Each Party shall designate a senior management or executive level representative to negotiate the dispute;

**7.2** The representatives shall attempt, through good faith negotiations, to resolve the dispute by any means within their authority.

**7.3** If the issue remains unresolved after fifteen (15) days of good faith negotiations, the Parties shall attempt to resolve the disagreement by negotiations between legal counsel. If the

aforementioned process fails, the Parties shall resolve any remaining disputes through mediation to expedite the resolution of the dispute.

**7.4** The mediation process shall provide for the selection within fifteen (15) days by both Parties of a disinterested third person to serve as the mediator, shall be commenced within thirty (30) days of selection of a mediator, and shall be concluded within fifteen (15) days from the commencement of the mediation.

**7.5** The Parties shall equally bear the costs of any third party mediator in any alternative dispute resolution process.

**7.6** The dispute resolution process is a material condition to this Agreement and must be exhausted prior to either Party initiating legal action. . If, for any dispute or claim to which this Section applies, any Party commences an action without first attempting to resolve the matter through the process set forth in this Section, or refuses to comply with this Section after a request has been made, then that Party shall not be entitled to recover attorney fees, even if they would otherwise be available to that party in any such action. This dispute resolution process is not intended to nor shall be construed to change the time periods for filing a claim or action specified by Government Code §§ 900 et seq.

**8 Labor Code Compliance.** Contractor is aware of the requirements of Chapter 1 of Part 7 of Division 2 of the California Labor Code and applicable regulations which require the payment of prevailing wage rates (§1771, §1774, and §1775); employment of apprentices (§1777.5), certified payroll records (§1776), hours of labor (§1813 and §1815), debarment of contractors and subcontractors (§1777.1) and the performance of other requirements on “public works” and “maintenance” projects. The Services being performed under this Agreement are part of a “public works” or “maintenance” project, as defined in the Prevailing Wage Laws, Contractor agrees to fully comply with such Prevailing Wage Laws.

**8.1 Rates.** These prevailing wage rates are on file with the City and are available online at <http://www.dir.ca.gov/DLSR>. Each Contractor and Subcontractor must pay no less than the specified rates to all workers employed to perform the services described herein. The schedule of per diem wages is based upon a working day of eight hours. The rate for holiday and overtime work must be at least time and one-half. Contractor assumes all responsibility for such payments and shall defend, indemnify and hold the City harmless from any and all claims made by the State of California, the Department of Industrial Relations, any subcontractor, any worker, or any other third party.

**8.2 Registration with DIR.** Contractor warrants that it is registered with the Department of Industrial Relations and qualified to perform the services consistent with Labor Code section 1725.5.

**8.3 Monitoring.** This Agreement will be subject to compliance monitoring and enforcement by the DIR, under Labor Code section 1771.4.

**9. Ownership of Work.** All original documents prepared by Contractor for this Agreement, whether complete or in progress, are the property of the City, and shall be given to the City at the completion of Contractor’s Services, or within five (5) days of any demand from the City. No such documents shall be revealed or made available by Contractor to any third party without the City’s prior written consent.

**10. Independent Contractor Status.** Contractor is an independent contractor and is solely responsible for the acts of its employees or agents, including any negligent acts or omissions. Contractor is not City’s employee and Contractor shall have no authority, express or implied, to act on behalf of the City as an agent, or to bind the City to any obligation, unless the City provides prior written authorization. Contractor is free to work for other entities while under contract with the City. Contractor, and its agents or employees, are not entitled to City benefits. Contractor shall be solely responsible for, and shall save the City harmless from, all matters relating to the payment of Contractor’s employees, agents, subcontractors and subconsultants, including compliance with social security requirements, federal and State income tax withholding and all other regulations governing

employer-employee relations. The City reserves the right to contract with other firms and/or contractors during the term of this Agreement to provide the City the same or similar services that Contractor is providing to the City under this Agreement. Nothing contained in this Agreement guarantees Contractor a certain amount of work, and the City may, in its sole and absolute discretion, allocate and/or delegate work to Contractor so as to satisfy the City's needs.

**11. Conflicts of Interest.** Contractor (including its employees, agents, and subcontractors) shall not maintain or acquire any direct or indirect interest that conflicts with the performance of this Agreement. If Contractor maintains or acquires such a conflicting interest, the City may terminate any contract (including this Agreement) involving Contractor's conflicting interest.

**12. Rebates, Kickbacks, or Other Unlawful Consideration.** Contractor warrants that this Agreement was not obtained or secured through rebates, kickbacks, or other unlawful consideration either promised or paid to any City official or employee. For any breach of this warranty, City shall have the right, in its sole discretion, to terminate this Agreement without liability; to pay only for the value of the work actually performed; or to deduct from the contract price the value of the rebate, kickback, or other unlawful consideration; or otherwise recover the full amount of such rebate, kickback, or other unlawful consideration.

**13. Notices.** All notices, demands, or other communications which this Agreement contemplates or authorizes shall be in writing and shall be personally delivered or mailed to the other party to the addresses listed below. Communications shall be deemed to have been given and received on the first to occur of: (1) actual receipt at the address designated below, or (2) three working days after the deposit in the United States Mail of registered or certified mail, sent to the address designated below.

To City:

James Thompson  
Fleet Supervisor-APWA CPF  
City of Tracy  
520 N. Tracy Blvd  
Tracy, CA 95376

With a copy to:

City Attorney  
333 Civic Center Plaza  
Tracy, CA 95376

To Contractor:

PowerGen, Inc.  
793 S. Tracy Blvd. #307  
Tracy, CA 95376

**14. Miscellaneous.**

**14.1 Standard of Care.** Unless otherwise specified in this Agreement, the standard of care applicable to Contractor's services will be the degree of skill and diligence ordinarily used by reputable professionals performing in the same or similar time and locality, and under the same or similar circumstances.

**14.2 Amendments.** This Agreement may not be modified orally or in any manner other than by an agreement in writing signed by both Parties.

**14.3 Waivers.** Waiver of a breach or default under this Agreement shall not constitute a continuing waiver or a waiver of a subsequent breach of the same or any other provision of this Agreement. No waiver shall be effective unless it is in writing and signed by the waiving party.

**14.4 Assignment and Delegation.** Contractor may not assign, transfer or delegate this Agreement or any portion of it without the City's prior written consent. Any attempt to do so will be void.

City's consent to one assignment, transfer or delegation shall not be deemed to be a consent to any subsequent assignment, transfer or delegation.

**14.5 Jurisdiction and Venue.** The interpretation, validity, and enforcement of the Agreement shall be governed by and construed under the laws of the State of California. Any suit, claim, or legal proceeding of any kind related to this Agreement shall be filed and heard in a court of competent jurisdiction in the County of San Joaquin.

**14.6 Compliance with the Law.** Contractor shall comply with all applicable local, state, and federal laws, whether or not those laws are expressly stated in this Agreement.

**14.6.1 Hazardous Materials.** Contractor is responsible for all costs of clean up and/or removal of hazardous and toxic substances spilled as a result of performing their services.

**14.6.2 Non-discrimination.** Contractor represents and warrants that it is an equal opportunity employer and it shall not discriminate against any subcontractor, employee or applicant for employment because of race, religion, color, national origin, handicap, ancestry, sex or age. Contractor shall also comply with all applicable anti-discrimination federal and state laws, including but not limited to, the California Fair Employment and Housing Act (Gov. Code 12990 (a-f) et seq.).

**14.7 Business Entity Status.** Contractor is responsible for filing all required documents and/or forms with the California Secretary of State and meeting all requirements of the Franchise Tax Board, to the extent such requirements apply to Contractor. By entering into this Agreement, Contractor represents that it is not a suspended corporation and that it is authorized to do business in California and in good standing with all agencies having jurisdiction over Contractor. If Contractor is a suspended corporation at the time it enters this Agreement, City may take steps to have this Agreement declared voidable.

**14.8 Business License.** Before the City signs this Agreement, Contractor shall obtain a City of Tracy Business License. Contractor shall maintain an active City of Tracy Business License during the term of this Agreement.

**14.9 Successors and Assigns.** This Agreement shall inure to the benefit of and be binding upon the Parties hereto and their respective successors and assigns.

**14.10 Construction of Agreement.** Each Party hereto has had an equivalent opportunity to participate in the drafting of this Agreement and/or to consult with legal counsel. Therefore, the usual construction of an agreement against the drafting Party shall not apply hereto.

**14.11 Severability.** If a term of this Agreement is held invalid by a court of competent jurisdiction, the Agreement shall be construed as not containing that term, and the remainder of this Agreement shall remain in effect.

**14.12 Controlling Provisions.** In the case of any conflict between the terms of this Agreement and the Exhibits hereto, and Contractor's proposal (if any), the Agreement shall control. In the case of any conflict between the Exhibits hereto and the Contractor's proposal (if any), the Exhibits shall control.

**14.13 Entire Agreement.** This Agreement and the attached Exhibits comprise the entire integrated understanding between the Parties concerning the services to be performed. This Agreement supersedes all prior negotiations, representations or agreements. All exhibits attached hereto are incorporated by reference herein.

**14.14 Counterparts.** City and Contractor agree that this Agreement may be executed in two or more counterparts, each of which shall be deemed an original.

**14.15 Expenses for Enforcement.** Contractor and City agree that the prevailing party's reasonable costs, attorneys' fees and expenses, including investigation fees and expert witness fees, shall be paid by the non-prevailing party in any dispute involving the terms and conditions of this Agreement.

**15. Signatures.** The individuals executing this Agreement on behalf of Contractor represent and warrant that they have the right, power, legal capacity and authority to enter into and to execute this Agreement on behalf of Contractor.

**[SIGNATURES ON FOLLOWING PAGE]**

DRAFT

The Parties agree to the full performance of the foregoing terms.

**City of Tracy**

**PowerGen, Inc.**

\_\_\_\_\_  
By: Nancy D. Young  
Title: Mayor  
Date: \_\_\_\_\_

\_\_\_\_\_  
By: Victor Poley  
Title: Chief Executive Officer  
Date: \_\_\_\_\_

Federal Employer Tax ID No. 81-1050033

Attest:

\_\_\_\_\_  
Adrienne Richardson, City Clerk

\_\_\_\_\_  
By: Julie Poley  
Title: Secretary/Treasurer  
Date: \_\_\_\_\_

Approved as to form:

\_\_\_\_\_  
Bijal M. Patel, City Attorney

Exhibits:

- A Scope of Work
- B Compensation



EXHIBIT A - Scope of Work

Contractor shall supply the following rental equipment for the City of Tracy at 370 W. Arbor Avenue, Tracy, CA 95304.

Rental Equipment:

- 200KW Diesel Generator (2) – Triple Shift
- 200KW Diesel Generator (2) – Single Shift
- 800 AMP Panel with Breaker
- 1200 AMP Panel with Breaker
- 400 Amp Automatic Transfer Switch (2)
- Cable Ramps (16)
- Containment Berms (4)
- Cable and Pigtails

DRAFT

EXHIBIT B - Compensation

Generators and Accessories:

- 200KW Diesel Generator (2) – Triple Shift
  - 200KW Diesel Generator (2) – Single Shift
  - 800 AMP Panel with Breaker
  - 1200 AMP Panel with Breaker
  - 400 Amp Automatic Transfer Switch (2)
  - Cable Ramps (16)
  - Containment Berms (4)
  - Cable and Pigtails
    - Monthly Rental Rate: \$41,416.06
    - Tax at 8.25%: \$3,416.82
- Total: \$44,832.88**

**Grand Total Monthly Rate: \$44,832.88**

**Projected Rental Period: April 1, 2024 to June 30, 2025**

**Projected NTE: \$657,253.70**

**TRACY CITY COUNCIL**

**RESOLUTION NO. \_\_\_\_\_**

---

**(1) DETERMINING THAT COMPLIANCE WITH THE STANDARD PROCUREMENT PROCESS IS NOT IN THE BEST INTEREST OF THE CITY PURSUANT TO CALIFORNIA PUBLIC CONTRACT CODE SECTION 20301 AND TRACY MUNICIPAL CODE SECTION 2.20.180(B)(4) FOR ENTERING INTO A TWO AGREEMENTS WITH POWERGEN, INC. FOR THE RENTAL AND MAINTENANCE OF DIESEL GENERATORS REQUIRED AT THE TEMPORARY EMERGENCY HOUSING FACILITY;**

**(2) APPROVING AN INTERIM GENERAL SERVICES AGREEMENT WITH POWERGEN, INC. FOR NINE (9) MONTHS EFFECTIVE JULY 1, 2023 THROUGH MARCH 31, 2024 WITH A NOT-TO EXCEED AMOUNT TO \$617,539.47;**

**(3) APPROVING A NEW GENERAL SERVICES AGREEMENT WITH POWERGEN, INC. FOR THE RENTAL AND MAINTENANCE OF DIESEL GENERATORS REQUIRED AT THE CITY'S TEMPORARY EMERGENCY HOUSING FACILITY WITH A NOT TO EXCEED AMOUNT OF \$657,253.70 WITH AN INITIAL TERM FROM APRIL 1, 2024 THROUGH JUNE 30, 2025; AND**

**(4) AUTHORIZING THE CITY MANAGER TO EXTEND THE AGREEMENT UP TO ONE ADDITIONAL YEAR, SUBJECT TO THE NOT-TO-EXCEED AMOUNT.**

**WHEREAS**, On November 1, 2022, the City Council adopted Resolution No. 2022-162 ratifying various procurement contracts for goods and general services to implement interim housing solutions at the Temporary Emergency Housing Facility located at 370 Arbor Road in Tracy (Project Site); and

**WHEREAS**, Resolution No. 2022-162 authorized the General Services Agreement with PowerGen, Inc., (Powergen) for the provision of electrical generators and fuel tanks at the Project Site from November 1, 2022 to June 30, 2023 (Agreement); and

**WHEREAS**, the term of the Agreement expired on June 30, 2023, however, the City has not formally terminated the Agreement and has continued to receive services from Powergen through present time for which the City is current on payments, and a formal interim general services agreement is required to memorialize the exchange of services and payment for the period between July 1, 2023 and March 31, 2024; and

**WHEREAS**, the City is anticipating the need for such services through June 30, 2025 while permanent power supplies are procured and installed; and

**WHEREAS**, Staff performed informal bidding procedures to analyze alternatives to fulfillment of City needs for temporary power supply at the project Site through June 30, 2025,

including by obtaining estimates for delivery of the same services supplied by Powergen; Staff worked with Powergen to negotiate a lower monthly rental rate that was comparable to the other quotes obtained; and

**WHEREAS**, staff determined the cost of the services across multiple proposers was equivalent, and that if another vendor was selected and Powergen terminated, the homeless shelter at the Project Site would lose one or more days of electricity as a result of the required removal and transition of electrical equipment from Powergen to a new contractor; and

**WHEREAS**, for the foregoing reasons, pursuant to Tracy Municipal Code Section 2.20.180 (b)(4) it is in the City’s best interest not to comply with formal bidding requirements requiring public advertisement and selection of the “lowest responsible” bidder; and

**NOW THEREFORE**, be it

**RESOLVED:** pursuant to Tracy Municipal Code Section 2.20.180(b)(4), the City Council hereby determines that entering into the Interim General Services Agreement with PowerGen, Inc. attached hereto as Attachment 1 in strict compliance with the standard procurement process is not in the best interest of the City; and be it further

**RESOLVED:** pursuant to Tracy Municipal Code Section 2.20.180(b)(4), the City Council hereby determines that entering into the General Services Agreement with PowerGen, Inc. attached hereto as Attachment 2 in strict compliance with the standard procurement process is not in the best interest of the City; and be it further

**RESOLVED:** That the City Council for the City of Tracy approves the interim General Services Agreement with PowerGen, Inc. attached hereto as Attachment 1 for the rental and maintenance of diesel generators required at the Temporary Emergency Housing Facility for an nine (9) months commencing July 1, 2023 and automatically expiring March 31, 2024 with a not-to exceed amount to \$617,539.47; and be it further

**RESOLVED:** the City Council approves the General Services Agreement with PowerGen, Inc., attached hereto as Attachment 2 with a not-to-exceed amount of \$657,253.70 for the rental and maintenance of diesel generators required at the Temporary Emergency Housing Facility with an initial term from April 1, 2024 through June 30, 2025, with an administrative option to extend for an additional year subject to the not-to-exceed amount; and be it further

**RESOLVED:** That the City Council authorizes the Mayor to execute the Interim General Services Agreement with PowerGen, Inc., attached hereto as Attachment 1; and be it further

**RESOLVED:** That the City Council authorizes the Mayor to execute the General Services Agreement with PowerGen, Inc., attached hereto as Attachment 2.

\* \* \* \* \*

The foregoing Resolution 2024-\_\_\_\_\_ was adopted by the City Council on \_\_\_\_\_, by the following vote:

AYES:	COUNCIL MEMBERS:
NOES:	COUNCIL MEMBERS:
ABSENT:	COUNCIL MEMBERS:
ABSTENTION:	COUNCIL MEMBERS:

---

NANCY D. YOUNG  
Mayor of the City of Tracy, California

ATTEST: \_\_\_\_\_  
ADRIANNE RICHARDSON  
City Clerk and Clerk of the Council of the  
City of Tracy, California

ATTACHMENTS:

- (1) Interim General Services Agreement (Extending term to March 31, 2024)
- (2) General Services Agreement (Through June 30, 2025)

Agenda Item 3.D

RECOMMENDATION

**Staff recommends that the Tracy Homeless Advisory Committee recommend that the City Council adopt a resolution (1) determining that compliance with the standard procurement process is not in the best interest of the City pursuant to California Public Contract Code Section 20301 and Tracy Municipal Code Section 2.20.180(b)(4), and (2) approving a Purchase Agreement with Nelco Electrical Supply, Inc., in the amount of \$391,636.58, for the purchase of electrical equipment required for permanent power supplies.**

EXECUTIVE SUMMARY

Staff recommends that the Tracy Homeless Advisory Committee recommend that the City Council determine, pursuant to Tracy Municipal Code (TMC) Section 2.20.180(B)(4) and California Public Contract Code Section 20301, that compliance with the standard procurement process is not in the best interest of the City, and enter into an agreement with Nelco Electrical Supply, Inc. (Nelco) for the purchase of the electrical equipment required to provide permanent power at Temporary Emergency Housing Facility, CIP 71112, at 370 Arbor Avenue. Although Nelco was not the “lowest” responsible bidder as required under a strict reading of TMC 2.20.180, in terms of costs saved by the City by Nelco’s relatively expedited delivery time, Nelco’s bid offers the greatest net-savings for the City. The monthly costs for providing power to the Interim facilities, including the generator rental costs and fuel to operate the equipment 24/7 is averaging approximately \$91,000 per month.

BACKGROUND AND LEGISLATIVE HISTORY

On March 10, 2020, the Council adopted Resolution No. 2020-050, which declared a shelter crisis pursuant to California Government Code Section 8698.2. For the subsequent two years, the City actively pursued the development and construction of an interim temporary emergency housing shelter on City-owned land located on Arbor Avenue to serve as interim full-service temporary housing solution for the City’s unsheltered (the Project) until the completion of the permanent project improvements.

On September 1, 2020, City Council authorized the creation of a Capital Improvement Project (CIP) for the Temporary Emergency Housing Project on Arbor Avenue, CIP 71112 (Project) to create a safe and dignified facility for residents experiencing homelessness.

Phase I of the Temporary Emergency Housing Facility Project, demolition of the existing structures, site and preparation, and underground utilities began in May of 2022. Phase II of the Project, the Site Improvements including the Sprung Structure, were delayed due to funding and delays resulting from the implementation of the interim facilities.

The Phase III Interim Project facility was opened in December of 2022, housing up to 48 individuals in leased modular structures. A permanent power supply was in the proposed Phase II Project construction, but that Phase was postponed due to the costs related to expediting the completion of the interim facility preparation. Portable generators were leased to provide power for the site until equipment for a permanent power supply could be installed.

On July 5, 2023 City Council authorized the purchase of eight (8) custom container dormitories under Resolution 2023-140, to be installed as part of the Phase IV interim shelter facility



improvements. The Phase IV Interim Project facility was opened in December of 2023, providing housing for an additional 38 individuals.

In April of 2023, Engineering staff issued a Notice Inviting Bidders for two permanent power supply construction contracts, separately from the facility site improvements, to expedite the procurement and installation of the electrical equipment that had a thirty-seven (37) week lead time. In May of 2023, bids were received from two contractors for each power supply, and one contractor was the low bidder on both contracts. The contract was awarded to the low bidder for both projects by Council on July 05, 2023. The low bidder failed to submit correctly completed construction contract documents as required, was determined to be non-responsive, and all bids were rejected December of 2023.

The Goods Purchase Agreement **Attachment 1** will be replaced with an updated Goods Purchase Agreement at the Tracy Homeless Advisory Committee meeting.

### ANALYSIS

Staff and the project design consultants began contacting multiple vendors in December of 2023, requesting quotes for purchasing the necessary permanent electrical equipment, and if possible, expedited delivery. Quotes were received from four vendors.

Only one vendor (Nelco) was able to provide expedited delivery. The three other vendors were not able to offer that option, primarily due to shortages and long lead times on the high voltage components required.

Options	Vendor	Quote	Delivery Timeline
1	Nelco Electrical Supply, Inc., Tracy, CA	\$ 320,687.05	12-14 Weeks
2	Eaton, Inc., Roseville, CA	\$ 147,950.00	37-39 weeks
3	Schneider Electric, Inc., San Jose, CA	\$ 204,675.00	45 weeks
4	IEM Electrical, Fremont, CA	\$266,656.00	34 weeks

For purposes of comparison, the costs of two smaller components are not included in the total shown, because they were not included in all quotes. Costs shown do not include delivery and sales & use taxes.

Both Phase III and Phase IV interim housing facilities are now being powered by four (4) portable generators, consisting of two (2) primary generators and two (2) backup generators, required by South San Joaquin County Fire to maintain power to the Fire Alarm Monitoring System. Fuel costs have increased due to the higher demand of the additional facilities and residents.

The monthly costs for providing power to the Interim facilities, including the generator rental costs and fuel to operate the equipment 24/7 is averaging approximately \$91,000 per month.

There are two viable options for moving forward with the direct purchase of the electrical equipment:

Option 1: Nelco Electric, Inc.- The City will receive the switch gear within 14 weeks of the receipt of the executed agreement, which will allow installation sooner and the operation costs. This option has the potential to save approximate \$530,000 in temporary power operating costs. However, the initial price is \$320,687 which is \$172,737 more than Option 2.

Option 2: Eaton, Inc. - The City will receive the switch gear in 37-39 weeks at a cost of \$147,950. Operating costs will continue at \$91,000 per month, for continued program costs of approximately \$530,000.

Staff has reviewed both the initial cost of the equipment versus the ongoing operating costs and concluded that Option 1 has the most benefit to the City based on the savings of operations. Although Nelco was not the “lowest” responsible bidder as required under a strict reading of TMC 2.20.180, in terms of costs saved by the City by Nelco’s relatively expedited delivery time, Nelco’s bid offers the greatest net-savings for the City.

Tracy Municipal Code Section 2.20.180 (b)(4) states that exceptions to standard procurement procedures is allowable “When, in the determination of the City Council, compliance with the procedure is not in the best interest of the City for those commodities, equipment, or general services, the costs of which equal or exceed Fifty Thousand and no/100ths (\$50,000.00) Dollars.”

California Public Contract Code Section 20301(a) states: The purchase of all supplies, equipment, and materials, when the expenditure required exceeds one hundred fifty thousand dollars (\$150,000), shall be by contract let to the lowest responsible bidder, or, in the authority's discretion, to the responsible bidder who submitted a proposal that provides the best value to the authority on the basis of the factors identified in the solicitation. “Best value” means the overall combination of quality, price, and other elements of a proposal that, when considered together, provide the greatest overall benefit in response to the requirements described in the solicitation documents.

**FISCAL IMPACT**

The Temporary Emergency Homeless Shelter, CIP 71112, is an approved project in the City’s Capital Improvement Plan. Sufficient funds are available in the project for the purchase of the equipment, and the current project budget is as follows:

<b><u>Funding Source</u></b>	<b><u>Budget</u></b>	<b><u>Expenses</u></b>	<b><u>Balance</u></b>
American Rescue Plan Act - City of Tracy	\$ 4,500,000	\$ 3,102,205	\$ 1,397,795
San Joaquin County (ARPA) R1	\$ 3,661,113	\$ 3,661,113	\$ -
San Joaquin County (ARPA) R2	\$ 7,167,798	\$ -	\$ 7,167,798
HHAP	\$ 329,240	\$ 329,240	\$ -
HHAP R2	\$ 414,042	\$ 414,042	\$ -
Federal Grant	\$ 3,000,000	\$ -	\$ 3,000,000
CDBG (4 Grants)	\$ 1,185,461	\$ 836,294	\$ 349,167
Housing Asset Funds	\$ 690,000	\$ 101,841	\$ 588,159
<b>Current Budget</b>	<b>\$ 20,947,654</b>	<b>\$ 8,444,735</b>	<b>\$ 12,502,919</b>

**CEQA DETERMINATION**

Government Code section 8698.4 exempts the application of the California Environmental Quality Act (CEQA) to various actions taken by public agencies to implement the construction of a homeless shelter in response to a declared shelter crisis. In addition, the interim solutions taken thus far are in furtherance of and related to the permanent solution that will be implemented, referred to as the Temporary Emergency Housing Facility on Arbor Avenue (CIP 71112). A Notice of Exemption was issued on October 16, 2020, for the Temporary Emergency Housing site at 500 Arbor Avenue in accordance with Government Code sections 65660-65662 for Low Barrier navigation Centers and Section 15269c) of the CEQA Guidelines (14 Cal. Code Regs. 15269(c) for (Emergency Projects). No environmental impacts beyond those already analyzed for the CIP exist; accordingly, no further CEQA analysis is needed.

### STRATEGIC PLAN

This agenda item supports the Public Safety Strategic Priority, Implement the adopted Homelessness Strategic Plan. More specifically, by adopting this new resolution, the City Council would reaffirm their commitment to follow through with the strategic priorities set forth in their Strategic Plan.

### ACTION REQUESTED OF THE COMMITTEE

Staff recommends that the Tracy Homeless Advisory Committee recommend that the City Council adopt a resolution (1) determining that compliance with the standard procurement process is not in the best interest of the City pursuant to California Public Contract Code Section 20301 and Tracy Municipal Code Section 2.20.180(b)(4), and (2) approving a Purchase Agreement with Nelco Electrical Supply, Inc., in the amount of \$391,636.58, for the purchase of electrical equipment required for permanent power supplies.

Prepared by: Ilene Macintire, Senior Civil Engineer, Utilities

Reviewed by: Koosun Kim, PE, City Engineer  
Sara Cowell, Director of Finance  
Brian MacDonald, Interim Director of Public Works  
Kim Murdaugh, Interim Assistant City Manager  
Bijal Patel, City Attorney

Approved by: Midori Lichtwardt, City Manager

### ATTACHMENTS:

- (1) Goods Purchase Agreement – Nelco
- (2) Exhibit A-1 Bills of Material
- (3) Exhibit B-1 Estimate of Costs
- (4) Exhibit C-1 Sale Agreement Document

**CITY OF TRACY  
PURCHASE AGREEMENT FOR GOODS & COMMODITIES  
WITH NELCO ELECTRICAL SUPPLY, INC.**

This Purchase Agreement for Goods and Commodities ("**Agreement**") is made effective \_\_\_\_\_ ("**Effective Date**") by and between the City of Tracy, a municipal corporation ("**City**"), and Nelco Electrical Supply, Inc. a California Corporation ("**Seller**"). City and Seller are sometimes referred to individually as "**Party**" and collectively as "**Parties.**"

**RECITALS**

- A.** The City seeks to procure specialized electrical equipment to establish permanent power supply to the City's Temporary Emergency Housing Facility.
- B.** On March 10, 2020, pursuant to Resolution 2020-052, City Council declared that a shelter crisis existed in the City of Tracy, pursuant to California Government Code Section 8698.2. On September 1, 2020, pursuant to Resolution 2020-163, City Council authorized the creation of a Capital Improvement Project for the Temporary Emergency Housing Facility (Project) CIP 71112, on City-owned land of 4.8 acres located at 370 W Arbor Avenue (Project Site) to create a safe and dignified facility for residents experiencing homelessness.
- C.** Due to scarcity of permanent electrical equipment supply, for approximately 15 months, the Project has relied on temporary power supply from portable generators and external fuel tanks. The monthly costs for this temporary power supply to the Project is approximately \$100,000.
- D.** In April of 2023, Engineering staff advertised two separate permanent power supply construction contracts for bids, separately from other site improvements, to expedite the procurement of the electrical equipment required that had thirty-seven (37) week lead time. In May of 2023, bids were received from two contractors for each power supply, one contractor was the low bidder on both contracts. The contract was awarded to the low bidder for both projects by Council in July of 2023. The low bidder failed to submit correct complete construction contracts as required, was determined to be non-responsive, and all bids were rejected December of 2023.
- E.** In December of 2023, Staff contacted multiple equipment vendors for updated quotes and delivery lead times. Seller, Nelco Electrical Supply, Inc., was the only vendor able to provide expedited delivery of the electrical equipment required for permanent power to the Project Site. Seller has committed to delivery of the equipment within 14 days of execution of this Agreement.
- F.** This Purchase Agreement will enable timely installation of power equipment required for the permanent connections to PG&E and the power grid, which, once installed on the site by a contractor, will eliminate the monthly cost associated with providing temporary power to the Project Site. City staff determined that Vendor possesses the skills and experience required to provide the requisite Goods for the Project. The Seller was the only vendor able to expedite the delivery of the equipment within the City's timelines.

- G.** [Insert applicable procurement policies and actions taken in compliance therewith] This Agreement is executed pursuant to City purchasing policies for goods, commodities, and equipment (Tracy Municipal Code (TMC) § 2.50.150 et. seq). In compliance with the formal contracting procedures of TMC § 2.20.180 for purchases of goods of \$50,000 or greater, the City published a public notice inviting bids. Seller's bid was selected because Seller was determined to be the lowest responsible bidder or because the City Council has made express findings that selection of Seller was in the best interest of the City.
- H.** The Tracy City Council approved this Agreement on \_\_\_\_\_ 2024 pursuant to Resolution No. \_\_\_\_\_.

NOW THEREFORE, for good and valuable consideration the sufficiency of which the Parties hereby acknowledge, the Parties mutually agree as follows:

**1. PURCHASE OF GOODS.**

**1.1. Goods Description.**

- 1.1.1.** The City agrees to purchase, and the Seller agrees to sell, the certain electrical power equipment necessary for permanent power supply to a City project site, as more specifically outlined and described in the attached Exhibit A ("Goods") which is incorporated herein by this reference.
- 1.1.2.** [Optional for Custom Items Difficult to Replace] The Goods shall comply with all of the standards and specifications outlined in Exhibit A. Seller shall not modify or change the specifications of the Goods prior to delivery, and hereby expressly acknowledges the City's reliance on the unique specifications of the goods and affirms the merchant's warranty of fitness for a particular purpose.
- 1.1.3.** [Optional for Custom Items Difficult to Replace] Seller grants the exclusive right to purchase, acquire, and accept the Goods as of the Effective Date of this Agreement.

- 1.2. Purchase Price.** The total purchase price for the Goods, including sales and use taxes, and shipping and freight costs under this Agreement shall not exceed \$387,626.01 ("Purchase Price") as further detailed in Exhibit B hereto. Notwithstanding the foregoing, the payment of any funds under this Agreement shall be subject to the City of Tracy appropriation of funds for the Goods. This Agreement shall terminate in the event that such funds are not appropriated.

**1.3. Payment.**

- 1.3.1. Time for Payment.** The time and method for payment of the Purchase Price is set forth Exhibit C hereto, except where otherwise expressly stated in this Section.
- 1.3.2. Method of Payment.** City payments shall be executed on the first City business day the payment is due. City payments may be made by check

or electronic wire transfer to Seller's designated financial institution in the City's sole discretion.

- 1.4. **Taxes.** The Seller must separately state on all invoices any taxes imposed by the local, state, or federal state government applicable to furnishing of the Goods provided, however, where a tax exemption is available, the tax must be subtracted from the total price and identified. Unless otherwise outlined in this Agreement, the Purchase Price will be considered to include state and city sales or use tax.

2. **DELIVERY.**

- 2.1. **Goods Delivery Location.** The Seller shall ensure the manufacturer ships the Goods and the Goods timely arrive at the City's facility, at 232 W. Larch Rd. Suite A, 370 W Arbor Avenue, Tracy CA, 95304 ("Delivery Location").

2.2. **Time for Delivery.**

2.2.1. Seller shall cause delivery of the Goods no later than fourteen (14) weeks after the date of City's delivery of the First Installment of the Purchase Price ("Delivery Date") as further detailed in Payment and Delivery Timeline in Exhibit C. Partial delivery of the Goods or any delivery of goods not in full compliance with the Goods as described in Exhibit A hereto shall not constitute Seller compliance with the Delivery Date.

2.2.2. Time is of the essence for Seller's delivery of the Goods, and the Delivery Date(s) described herein are material terms of this Agreement. Seller's failure to timely deliver the Goods no later than the Delivery Date is a material breach of this Agreement entitling City, in its discretion, to terminate this Agreement without liability with written notice to Seller and recover from Seller any and all costs. Seller shall notify City immediately upon reasonably discovering Seller cannot comply with the Delivery Date.

2.2.3. In the event the City elects not to terminate this Agreement if Seller fails to comply with the Delivery Date, Seller agrees to immediately pay City liquidated damages in accordance with the terms and conditions set forth in Exhibit C hereto, if any ("Delay Costs"). Seller acknowledges the Late Costs are a reasonable and accurate measure of actual damages and costs incurred by the City as a result of Seller's delays in complying with the Delivery Date, and agree to pay the Delay Costs as further consideration for the mutual covenants herein.

- 2.3. **Acceptance.** The City or its designee shall have the right of reasonable inspection and testing of the Goods to verify Seller's performance of its obligations of this Agreement and that the Goods conform to applicable specifications and are in good working order. The City's date of Acceptance shall be the latest occurrence of one of the following events: (a) 30 days following Seller's delivery of the Goods; (b) the date City delivers a written "Notice of Acceptance;" or (c) final payment of the Purchase Price ("Acceptance Date"). City may terminate this Agreement prior to the Acceptance Date with written notice to Seller if the Goods are defective or non-conforming to the applicable specifications.



- 2.4. Risk of Loss.** All orders will be Free on Board (FOB) destination if not otherwise specified. Risk of loss or damage to the Goods shall remain with the Seller until the Goods have been timely delivered to and accepted by the City. All Goods will be received by the City subject to its right of inspection, rejection, and revocation of acceptance under the Uniform Commercial Code. The City will be allowed a reasonable period of time to inspect the Goods and to notify Seller of any nonconformance with the terms and conditions of the specifications. The City may reject any Goods that do not conform to the terms and conditions outlined under Exhibits A, B and C. Any Goods rejected may be returned to the Seller at the Seller's risk and expense.
- 2.5. Packing and Shipping.** Deliveries must be made as specified in Exhibit C, without charge for boxing, crating, or storage unless otherwise specified. Goods must be suitably packed to secure the lowest transportation costs and, in accordance with the requirements of common carriers, in a manner to assure against damage from weather or transportation. The City's order numbers and symbols must be plainly marked on all invoices, packages, and shipping orders. Packing lists specifying the quantity, description, must accompany each box or packing shipment and must be submitted to the City as verification that the installed equipment is per the final design and Agreement.

### **3. REPRESENTATIONS & WARRANTIES.**

#### **3.1. Seller Warranties.**

- 3.1.1.** Seller represents it has full power and authority to enter into and perform the obligations contemplated by the Purchase Agreement.
- 3.1.2.** The Seller warrants that all Goods will conform to applicable specifications, drawings, descriptions, and samples, and will be merchantable, of good workmanship in material, and free from defect. Unless manufactured according to detailed design furnished by the City, the Seller assumes design responsibility and warrants the Goods to be free from design defect and suitable for the purposes intended by the City, and that such Goods if installed by the Seller shall conform to applicable specifications.
- 3.1.3.** Seller warrants the Goods are free from any encumbrance, lien, or any security interest, and that Seller has no reason to know of any claim of title hostile to the rights of Seller to the Goods.
- 3.1.4.** If services are to be provided hereunder, Seller warrants that it or its subcontractor(s) shall provide the testing, installation, maintenance and other services as required to accomplish delivery and proper functioning of the Goods in accordance with applicable specifications. Seller shall cause such services to be performed in a professional and workmanlike manner. Supplier further warrants that the Goods will be free from defects in workmanship, design, and materials and will conform to and perform in accordance with functional specifications and descriptions. In the event of any breach of the foregoing warranty, Seller shall promptly, without additional charge, repair or replace the Goods as necessary in order to

meet its performance obligations hereunder. If Seller fails to repair or replace (with its functional equivalent) the Goods within thirty (30) days of notice, City has the right to terminate this Agreement, and Seller shall promptly refund to City all payments, fees, and charges hereunder.

**3.1.5.** Seller's representations and warranties include those Supplemental Representations & Warranties attached hereto as Exhibit D, and are incorporated herewith by reference.

**3.1.6.** Unless otherwise expressly stated to the contrary herein, Seller's warranties shall expire one (1) year following City's final payment of the balance of the Purchase Price.

**3.2. Manufacturer Warranties.** The Manufacturer's warranties, together with its service guarantees, are hereby assigned to the City and shall run to the City and must not be deemed exclusive to Seller. The City's inspection, approval, acceptance, use of, and payment for all or any part of the Goods must in no way affect its warranty rights whether or not a breach of warranty had become evident in time.

**4. CONFLICTS OF INTEREST.** Seller (including its employees, agents, and sub-sellers) shall not maintain or acquire any direct or indirect interest that conflicts with the performance of this Agreement. If Seller maintains or acquires such a conflicting interest, the City may terminate any contract (including this Agreement) involving Seller's conflicting interest. The Seller represents that it is familiar with the local and state conflict of interest laws, and agrees to comply with those laws in performing this Agreement. The Seller represents and warrants that the representations made by the Seller concerning unfair competitive advantage and conflicts of interest in connection with its submissions in response to the City's procurement for this Agreement were true and accurate both when made and as of the date of this Agreement. Seller represents and warrants that it has not and shall not offer or deliver any City officer, public official, or employee any gifts or donations in violation Federal, State and/or local law. Seller warrants that this Agreement was not obtained or secured through rebates, kickbacks, or other unlawful consideration either promised or paid to any City official or employee. For any breach of this warranty, City shall have the right, in its sole discretion, to terminate this Agreement without liability; to pay only for the value of the work actually performed; or to deduct from the contract price the value of the rebate, kickback, or other unlawful consideration; or otherwise recover the full amount of such rebate, kickback, or other unlawful consideration.

**5. INDEMNIFICATION.**

**5.1.** Seller and its employees, agents and subcontractors, shall, to the fullest extent permitted by law, indemnify, defend (with independent counsel approved by the City), and hold harmless the City from and against, and reimburse the City, including City officials, officers, agents, employees and volunteers, for, any and all liabilities, obligations, losses, damages, injunctions, suits, actions, fines, penalties, claims, demands, administrative and judicial proceedings and order, judgments, remedial action requirements, costs and expenses of every kind or nature, and all costs and expenses incurred in connection therewith, including, without limitation, reasonable attorneys' fees and court costs ("Claims") arising directly or indirectly from or out of (including any and all related costs and expenses), relating or pertaining to or resulting from, in whole or in part, this Agreement; the Goods; any act, omission, or

event relating in any way to Seller's obligations under this Agreement; and/or Seller's breach of this Agreement, except to the extent such Claim is caused solely by the active negligence or willful misconduct of the City.

- 5.2. Seller shall further defend, indemnify, and hold harmless City (including its employees, agents, and/or affiliates) against any property damage or loss to its plant or facilities caused or occasioned by the malfunction or nonfunction of the Goods where such malfunction or nonfunction is attributed to the acts or omissions of Seller in the installation, maintenance, or operation of the Goods.
- 5.3. Seller's indemnification obligations hereunder shall survive termination of this Agreement.
- 6. **INSURANCE**. From the Effective Date and throughout Seller's full performance of this Agreement, Seller shall maintain the minimum insurance requirements stated in Exhibit E hereto.
- 7. **NOTICES**. All notices, demands, or other communications which this Agreement contemplates or authorizes shall be in writing and shall be personally delivered or mailed to the other party to the addresses listed below. Communications shall be deemed to have been given and received on the first to occur of: (1) actual receipt at the address designated below, or (2) three working days after the deposit in the United States Mail of registered or certified mail, sent to the address designated below.

To the City:

City of Tracy  
Attn: [Name], [Title]  
333 Civic Center Plaza  
Tracy, CA 95376

To Seller:

[Name of Entity]  
Attn: [Name, Title]  
[Address]

With a copy to:  
City Attorney  
333 Civic Center Plaza  
Tracy, CA 95376

8. **GENERAL PROVISIONS.**

8.1. **Conflicts Of Interest.**

8.1.1. Seller (including its employees, agents, and subcontractors) shall not maintain or acquire any direct or indirect interest that conflicts with the performance of this Agreement. If Seller maintains or acquires such a conflicting interest, the City may terminate any contract (including this Agreement) involving Seller's conflicting interest. The Seller represents that it is familiar with the local and state conflict of interest laws, and agrees to comply with those laws in performing this Agreement. The Seller represents and warrants that the representations made by the

Seller concerning unfair competitive advantage and conflicts of interest in connection with its submissions in response to the City's procurement for this Agreement were true and accurate both when made and as of the date of this Agreement. Seller represents and warrants that it has not and shall not offered or delivered any City officer, public official, or employee any gifts or donations in violation Federal, State and/or local law.

- 8.1.2.** Seller warrants that this Agreement was not obtained or secured through rebates, kickbacks, or other unlawful consideration either promised or paid to any City official or employee. For any breach of this warranty, City shall have the right, in its sole discretion, to terminate this Agreement without liability; to pay only for the value of the work actually performed; or to deduct from the contract price the value of the rebate, kickback, or other unlawful consideration; or otherwise recover the full amount of such rebate, kickback, or other unlawful consideration.
- 8.2. Amendments.** This Agreement may not be modified orally or in any manner other than by an agreement in writing signed by both Parties.
- 8.3. Waivers.** Waiver of a breach or default under this Agreement shall not constitute a continuing waiver or a waiver of a subsequent breach of the same or any other provision of this Agreement. No waiver shall be effective unless it is in writing and signed by the waiving party.
- 8.4. Assignment and Delegation.** Seller may not assign, transfer or delegate this Agreement or any portion of it without the City's advance written consent. Any attempt to do so will be void. City's consent to one assignment, transfer or delegation shall not be deemed to be a consent to any subsequent assignment, transfer or delegation.
- 8.5. Jurisdiction and Venue.** The interpretation, validity, and enforcement of the Agreement shall be governed by and construed under the laws of the State of California. Any suit, claim, or legal proceeding of any kind related to this Agreement shall be filed and heard in a court of competent jurisdiction in the County of San Joaquin.
- 8.6. Compliance with the Law.** Seller shall comply with all applicable local, state, and federal laws, including, without limitation, those identified below, whether or not such laws are expressly stated in this Agreement.
- 8.7. Successors and Assigns.** This Agreement shall inure to the benefit of and be binding upon the Parties hereto and their respective successors and assigns.
- 8.8. Construction of Agreement.** Each Party hereto has had an equivalent opportunity to participate in the drafting of this Agreement and/or to consult with legal counsel. Therefore, the usual construction of an agreement against the drafting Party shall not apply hereto.

- 8.9. **Severability.** If a term of this Agreement is held invalid by a court of competent jurisdiction, the Agreement shall be construed as not containing that term, and the remainder of this Agreement shall remain in effect.
- 8.10. **Controlling Provisions.** In the case of any conflict between the terms of this Agreement and the Exhibits hereto and Seller's proposal (if any), the Agreement shall control. In the case of any conflict between the Exhibits hereto and the Seller's proposal (if any), the Exhibits shall control.
- 8.11. **Entire Agreement.** This Agreement and the attached Exhibits comprise the entire integrated understanding between the Parties concerning the services to be performed and the matters contemplated herein. This Agreement supersedes all prior negotiations, representations or agreements (in each case, whether oral or in writing). All exhibits attached hereto are incorporated by reference herein.
- 8.12. **Counterparts.** City and Seller agree that this Agreement may be executed in two or more counterparts, each of which shall be deemed an original.
- 8.13. **Expenses for Enforcement.** Seller and City agree that the prevailing party's reasonable costs, attorneys' fees and expenses, including investigation fees and expert witness fees, shall be paid by the non-prevailing party in any dispute involving the terms and conditions of this Agreement.
- 8.14. **Signatures.** The individuals executing this Agreement on behalf of Seller represent and warrant that they have the right, power, legal capacity and authority to enter into and to execute this Agreement on behalf of Seller.

[Signature Page to Follow]

IN WITNESS HEREOF, the Parties agree to the full performance of the terms set forth in this Agreement and have caused this Agreement to be duly executed as of the Effective Date.

**City of Tracy, a Municipal Corporation**

**Seller**

\_\_\_\_\_  
By: Nancy D. Young  
Title: Mayor

Nelco Electrical Supply, Inc.  
(A California Corporation)

Date: \_\_\_\_\_

\_\_\_\_\_  
By: Nicholas Locatelli  
Title: President and CFO  
Date: \_\_\_\_\_

Attest:

Federal Employer Tax ID No. \_\_\_\_\_

\_\_\_\_\_  
Adrienne Richardson, City Clerk

Approved as to form:

\_\_\_\_\_  
Bijal Patel  
City Attorney

Exhibits:

- A Description of Goods
- B Purchase Price
- C Payment and Delivery Timeline
- D Supplemental Seller Representations & Warranties
- E Insurance Requirements



**EXHIBIT A – Specification of the Goods**

(see attached)

The Goods, as described in this Purchase Agreement, defined in this Exhibit A shall include all of the following items, components, specifications, plans, and standards, in addition to any supplemental specifications attached hereto:

1. 2500 Amp 120/208v 3P 4W Siemens Switchgear
2. 1600 Amp 120/208v 3P 4W Siemens Switchgear
3. 600 Amp 120/208v 3P 4W Distribution Board (Brand)
4. 400 Amp 120/208v 3P 4W Panel (Brand)
5. 100 Amp 120/208v 3P 4W Non-Fused Manual Transfer Switch (Brand)

(See attached Exhibit A-1 Bill of Materials and Plans for the listed equipment).

**EXHIBIT B**  
**Purchase Price**

Item No.	Description	Cost	Sales Tax (8.25%)	Estimated Shipping (5%)	Total
1	2500 Amp 120/208v 3P 4W Siemens Switchgear	\$152,697.22	\$12,597.52	\$7,634.86	\$172,929.60
2	1600 Amp 120/208v 3P 4W Siemens Switchgear	\$134,297.82	\$11,079.57	\$6,714.89	\$152,092.28
3	600 Amp 120/208v 3P 4W Distribution Board (Brand)	\$33,692.01	\$2,779.59	\$1,684.60	\$38,156.20
4	400 Amp 120/208v 3P 4W Panel (Brand)	\$11,246.54	\$927.84	\$562.33	\$12,736.71
5	100 Amp 120/208v 3P 4W Non-Fused Manual Transfer Switch (Brand)	\$1,511.01	\$124.66	\$75.55	\$1,711.22
6	Arc Flash Studies	\$10,000.00	N/A	N/A	\$10,000.00

**Total Purchase Price \$387,626.01**

Seller's Quotes are attached as Exhibit B-1 and B-2

See attached Exhibit B-1 and B-2 for equipment Quotations. (to be inserted in final document)  
Arc Flash Study estimate, actual cost TBD

## **EXHIBIT C**

### **Payment and Delivery Timelines**

- 1. Payment Timeline for Purchase Price.** The Parties agree to facilitate payment of the Purchase Price in accordance with the following sequence:
  - a. Seller will submit an invoice to the City for fifty percent (50%) of the Purchase Price associated sales tax upon receipt of the fully executed Agreement.
  - b. Seller will provide the City with written confirmation from the manufacturer, of the receipt of the order, and manufacturer's estimated shipping date. (12-14 weeks).
  - c. Upon City receipt of the Goods at the Seller's facility, located at 232 W. Larch Road, Suite A, Tracy, CA 95304, the Seller will submit an invoice to the City for forty percent (40%) of the Purchase Price and associated sales tax, and actual shipping fees.
  - d. Payment for the Arc Flash Study shall be made upon receipt of the completed, signed and stamped study.
  - e. The Seller will submit an invoice to the City for the balance of the Purchase Price and associated sales tax, and actual shipping fees, upon City written notice of acceptance that the Goods comply with the requirements of Exhibit A and this Agreement.
  - f. The Seller will contact the City and coordinate with the City to schedule the City, or its designated contractor, to retrieve the Goods from the Seller's facility. The City or its designated contractor will be responsible for delivery of the Goods to the City's Project site.
- 2. Timing of Delivery of Goods**
  - a. Seller shall give the City written confirmation when the order for the Goods has been acknowledged by the manufacturer and when it has been shipped.
  - b. The Seller shall deliver the Goods to the City within fourteen (14) weeks of the delivery of the First Installment for the Goods, beginning the Monday following the date of initial payment.
- 3. Delay Costs for Late Delivery.** If for any reason Seller fails to meet the Delivery Date set forth in the Agreement to which this Exhibit C is made a part, Seller shall immediately pay and compensate City the amount equal to 5% (Five Percent) of the Purchase Price for every additional Seven (7) days after the Delivery Date Seller fails to deliver the Goods in full conformity with this Agreement unless and until the City elects to terminate this Agreement.

**EXHIBIT D**

**Supplemental Seller Representations & Warranties**

In addition to those representations and warranties set forth in the Agreement to which this Exhibit D is an exhibit, Seller further represents and warrants as follows:

1. Seller warrants that the Goods was constructed in accordance with the approved plans and specifications and is free from defects. If the equipment fails or malfunctions within the Warranty period, the manufacturer will repair or replace at no cost to the City for two years from the date of delivery on all items sold.
2. The metered cabinets will be completed by Nelco Electrical Supply in 14 weeks, guaranteed.
3. Seller will submit final Manufacturer's Bill of Materials and Schematics for Engineer's approval, prior to the start of manufacturing of equipment.
4. The Goods shall meet all PG&E Requirements for service entrance equipment.
5. Anchorage calculations, including seismic calculations, will be provided by the manufacturer, and will be signed and stamped by a professional engineer licensed in the State of California.
6. The Electrical Engineer will provide requirements for an Arch Flash Study, to be completed by the Seller's consultant.

**EXHIBIT E** - Seller Insurance Requirements

Not Applicable – Intentionally Omitted.

Seller shall maintain the following minimum insurance coverages:

1. **COMMERCIAL GENERAL LIABILITY**. (with coverage at least as broad as ISO form CG 00 01 01 96) “per occurrence” coverage shall be maintained in an amount not less than \$2,000,000 general aggregate and \$1,000,000 per occurrence for general liability, bodily injury, personal injury, and property damage.

DRAFT

## BILL OF MATERIALS

**MSBDS 1 msbds -- SWITCHBOARD - 3 SECTIONS**

Incoming Location: Bottom, Incoming Position: Left,

Service Entrance: Yes, System: 208Y/120 3Ø4W WYE AC, 100,000 A, Bus Bracing:

100,000 A, Bus Material: 65°C Copper, Bus Rating: Non-Tapered, Incoming Bus

Amperage: 1,600 A, Enclosure Rating: 3R - Outdoor, Flat Roof.

**SECT.1-AUXILIARY**

Section Type: Incoming Bussed Pull.

1 - 100KA Bus Bracing

1 - Nameplate

1 - Standard Frame

1 - 65°C Copper Neutral

1 - 1,600 Amp Top Thru Bus

1 - Outdoor Construction, Flat Roof, 11.000 Front Extension

1 - 500 Kcmil Provision Only 1600A Comp Lug Provisions

1 - Section Barrier

1 - Copper Ground Bus

1 - INCOMING LUGS: N/A

**SECT.2-MAIN**

Section Type: Main Service.

1 - 100KA Bus Bracing

1 - Standard Frame

1 - 1,600 Copper Section Bus

1 - 65°C Copper Neutral

1 - 1,600 Amp Top Thru Bus

1 - 1,600 Amp Bottom Thru Bus

1 - Outdoor Construction, Flat Roof, 11.000 Front Extension

1 - Copper Ground Bus

1 - Section Barrier

1 - (1)#6-300MCM Ground Lug

1 - 1,600 Amp Interconnection Components

1 - PACIFIC GAS ELEC UTILITY METERING COMPARTMENT

1 - 1600A EUSERC Utility Meter Provision

1 - 1,600 A/3 Main 3WA Breaker

1 - Breaker Catalog #: 3WA2216-5AE02-0AA0

1 - Standard DAS (Dynamic Arc-Flash Sentry) Maintenance Mode, 3WA

Std

1 - 1600 A/3P 3WA Breaker 1,600 A Rating Plug

1 - Ready-to-Close

1 - ETU600 LSI

1 - H Class - Frame Size 2

1 - Fixed Mounted

SECT.3-DISTRIBUTION

Section Type: Distribution Panel.

- 1 - 100KA Bus Bracing
- 1 - Standard Frame
- 1 - 1,600 Copper Section Bus
- 1 - 1,600 Amp Bottom Thru Bus
- 1 - Outdoor Construction, Flat Roof, 11.000 Front Extension
- 1 - Copper Ground Bus
- 1 - Wire Marker Labels
- 1 - 1,600 Amp Interconnection Components
- 1 - AUXILIARY COMPARTMENT
- 1 - Surge Protective Device - 400kA Distribution SPD
- 1 - SPD Surge Counter
- 1 - US2:TPS4C0540X2
- 1 - 600 A/3P 3VA54-HLAS Branch
- 1 - Catalog #: 3VA54606EC310AA0
- 1 - 600 A/3P 3VA54
- 1 - Model TM230 FTAM
- 1 - (2)2/0-500 KCMIL CU/AL
- 1 - 600 A/3P 3VA54-HLAS Branch Provision
- 1 - Provision - Panel Mount 600A 3VA MCCB
- 2 - 400 A/3P 3VA53-HJAS Branch
- 1 - Catalog #: 3VA53406EC310AA0
- 1 - 400 A/3P 3VA53
- 1 - Model TM230 FTAM
- 1 - (2)2/0-250 KCMIL CU/AL
- 2 - 400 A/3P 3VA53-HJAS Branch Provision
- 1 - Provision - Panel Mount 400A 3VA MCCB
- 1 - 225 A/3P 3VA52-HFAS Branch
- 1 - Catalog #: 3VA52226EC310AA0
- 1 - 225 A/3P 3VA52
- 1 - Model TM230 FTAM
- 1 - (1)#6-350 KCMIL Cu/Al
- 1 - 70 A/3P 3VA52-HFAS Branch
- 1 - Catalog #: 3VA52706EC310AA0
- 1 - 70 A/3P 3VA52
- 1 - Model TM230 FTAM
- 1 - (1)#6-350 KCMIL Cu/Al
- 11 - 125 A/3P 3VA41-HEAB Branch
- 1 - Catalog #: 3VA41126ED340AA0
- 1 - 125 A/3P 3VA41
- 1 - Model TM210 FTFM
- 1 - (1)#14-3/0 KCMIL CU/AL

**MSBDS 1 MSBDS --SB2 SWITCHBOARD - 3 SECTIONS**

Incoming Location: Bottom, Incoming Position: Left,

Service Entrance: Yes, System: 208Y/120 3Ø4W WYE AC, 100,000 A, Bus Bracing: 100,000 A, Bus Material: 65°C Copper, Bus Rating: Non-Tapered, Incoming Bus Amperage: 2,500 A, Enclosure Rating: 3R - Outdoor, Flat Roof.

SECT.1-AUXILIARY

Section Type: Incoming Bussed Pull.

- 1 - 100KA Bus Bracing
- 1 - Standard Frame
- 1 - Nameplate



- 1 - 65°C Copper Neutral
- 1 - 2,500 Amp Top Thru Bus
- 1 - Outdoor Construction, Flat Roof, 11.000 Front Extension
- 1 - Section Barrier
- 1 - Copper Ground Bus
- 1 - 500 Kcmil Provision Only 2500A Comp Lug Provisions
- 1 - INCOMING LUGS: N/A

SECT.2-MAIN

Section Type: Main Service.

- 1 - 100KA Bus Bracing
- 1 - 2,500 Copper Section Bus
- 1 - 2,500 Amp Top Thru Bus
- 1 - 65°C Copper Neutral
- 1 - 2,500 Amp Bottom Thru Bus
- 1 - Outdoor Construction, Flat Roof, 11.000 Front Extension
- 1 - Copper Ground Bus
- 1 - Section Barrier
- 1 - (1)#6-300MCM Ground Lug
- 1 - 2,500 Amp Interconnection Components
- 1 - PACIFIC GAS ELEC UTILITY METERING COMPARTMENT
- 1 - 2500A EUSERC Utility Meter Provision
- 1 - 2,500 A/3 Main 3WA Breaker
- 1 - Breaker Catalog #: 3WA2225-5AE02-0AA0
- 1 - Standard DAS (Dynamic Arc-Flash Sentry) Maintenance Mode, 3WA Std

- 1 - ETU600 LSI
- 1 - Auxiliary Switch - 2 NO and 2 NC (SB3)
- 1 - H Class - Frame Size 2
- 1 - Fixed Mounted
- 1 - 2500 A/3P 3WA Breaker 2,500 A Rating Plug

SECT.3-DISTRIBUTION

Section Type: Distribution Panel.

- 1 - 100KA Bus Bracing
- 1 - 2,500 Copper Section Bus
- 1 - 2,500 Amp Bottom Thru Bus
- 1 - Outdoor Construction, Flat Roof, 11.000 Front Extension
- 1 - Copper Ground Bus
- 1 - Special shipping skid for large sections
- 1 - Wire Marker Labels
- 1 - 2,500 Amp Interconnection Components
- 1 - AUXILIARY COMPARTMENT
- 1 - Surge Protective Device - 400kA Distribution SPD
- 1 - SPD Surge Counter
- 1 - US2:TPS4C0540X2
- 2 - 600 A/3P 3VA54-HLAS Branch Provision
- 1 - Provision - Panel Mount 600A 3VA MCCB
- 1 - 600 A/3P 3VA54-HLAS Branch
- 1 - Catalog #: 3VA54606EC310AA0
- 1 - 600 A/3P 3VA54
- 1 - Model TM230 FTAM
- 1 - (2)2/0-500 KCMIL CU/AL
- 3 - 400 A/3P 3VA53-HJAS Branch
- 1 - Catalog #: 3VA53406EC310AA0
- 1 - 400 A/3P 3VA53

- 1 - Model TM230 FTAM
- 1 - (2)2/0-250 KCMIL CU/AL
- 1 - 400 A/3P 3VA53-HJAS Branch Provision
- 1 - Provision - Panel Mount 400A 3VA MCCB
- 2 - 250 A/3P 3VA52-HFAS Branch Provision
- 1 - Provision - Panel Mount 250A 3VA MCCB
- 1 - TO FILL A 3VA52, PROVISION #S3VA52PR
- 4 - 225 A/3P 3VA52-HFAS Branch
- 1 - Catalog #: 3VA52226EC310AA0
- 1 - 225 A/3P 3VA52
- 1 - Model TM230 FTAM
- 1 - (1)#6-350 KCMIL Cu/Al

### **SP3 1 SP3 - SWITCHBOARD - 1 SECTION**

Incoming Location: Top, Incoming Position: Left, Service  
 Entrance: No, System: 208Y/120 3Ø4W WYE AC, 65,000 A, Bus Bracing: 65,000 A,  
 Bus Material: 65°C Copper, Bus Rating: Non-Tapered, Incoming Bus Amperage:  
 600 A, Enclosure Rating: 3R – Outdoor Flat Roof.

SECT. 1-MAIN

Section Type: Panel Mounted Main Section.

- 1 - Nameplate
- 1 - 600 Copper Section Bus
- 1 - Outdoor Construction, Flat Roof, 11.000 Front Extension
- 1 - 500 Kcmil Al/Cu 400-800A Mechanical Lugs
- 1 - Copper Ground Bus
- 1 - Top cable N3R Customer must seal cutouts
- 1 - (1)#6-300MCM Ground Lug
- 1 - INCOMING LUGS: (2) 500 KCMIL AL/CU MECH
- 1 - 600 A/3P 3VA54-MLAS Main
- 1 - Catalog #: 3VA54605EC310AA0
- 1 - 600 A/3P 3VA54
- 1 - Model TM230 FTAM
- 13 - 125 A/3P 3VA52-MFAS Branch
- 1 - Catalog #: 3VA52125EC310AA0
- 1 - 125 A/3P 3VA52
- 1 - Model TM230 FTAM
- 1 - (1)#6-350 KCMIL Cu/Al
- 1 - 200 A/3P 3VA52-MFAS Branch
- 1 - Catalog #: 3VA52205EC310AA0
- 1 - 200 A/3P 3VA52
- 1 - Model TM230 FTAM
- 1 - (1)#6-350 KCMIL Cu/Al
- 8 - 125 A/3P 3VA52-MFAS Branch Provision
- 1 - Provision - Panel Mount 250A 3VA MCCB
- 1 - TO FILL A 3VA52, #S3VA52PR

### **Nick Locatelli**

Main: 209.699.3049  
 Emergency Service: 408.438.0373  
 232 W. Larch Rd. Suite A  
 Tracy, CA 95304  
 NelcoElectricalSupply.com



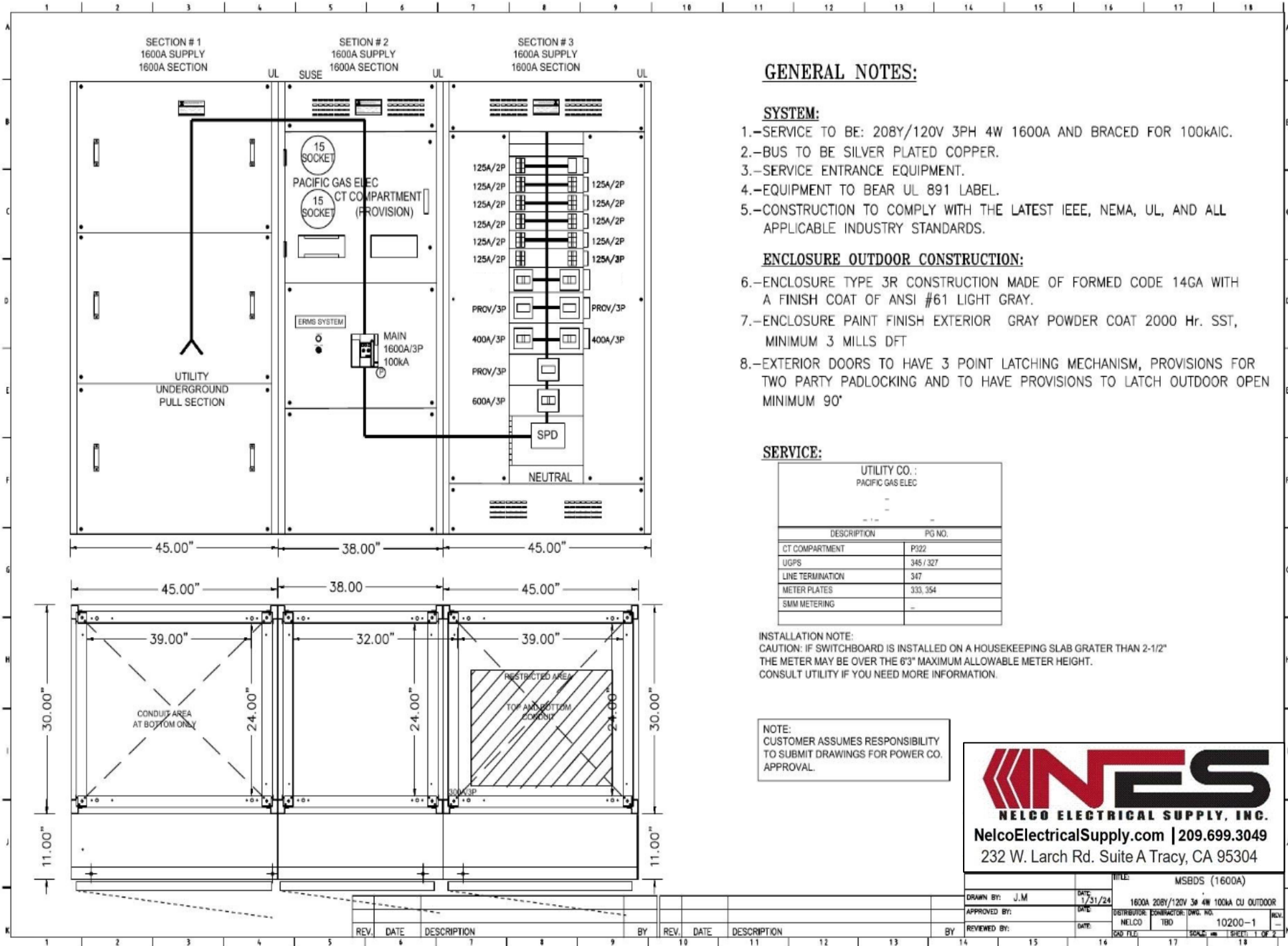

**GENERAL NOTES:**

**SYSTEM:**

- 1.-SERVICE TO BE: 208Y/120V 3PH 4W 1600A AND BRACED FOR 100KAIC.
- 2.-BUS TO BE SILVER PLATED COPPER.
- 3.-SERVICE ENTRANCE EQUIPMENT.
- 4.-EQUIPMENT TO BEAR UL 891 LABEL.
- 5.-CONSTRUCTION TO COMPLY WITH THE LATEST IEEE, NEMA, UL, AND ALL APPLICABLE INDUSTRY STANDARDS.

**ENCLOSURE OUTDOOR CONSTRUCTION:**

- 6.-ENCLOSURE TYPE 3R CONSTRUCTION MADE OF FORMED CODE 14GA WITH A FINISH COAT OF ANSI #61 LIGHT GRAY.
- 7.-ENCLOSURE PAINT FINISH EXTERIOR GRAY POWDER COAT 2000 Hr. SST, MINIMUM 3 MILLS DFT
- 8.-EXTERIOR DOORS TO HAVE 3 POINT LATCHING MECHANISM, PROVISIONS FOR TWO PARTY PADLOCKING AND TO HAVE PROVISIONS TO LATCH OUTDOOR OPEN MINIMUM 90°

**SERVICE:**

UTILITY CO. : PACIFIC GAS ELEC	
-	
-	
-	
DESCRIPTION	PG NO.
CT COMPARTMENT	P322
UGPS	345 / 327
LINE TERMINATION	347
METER PLATES	333, 354
SMM METERING	-

INSTALLATION NOTE:  
CAUTION: IF SWITCHBOARD IS INSTALLED ON A HOUSEKEEPING SLAB GRATER THAN 2-1/2" THE METER MAY BE OVER THE 8"3" MAXIMUM ALLOWABLE METER HEIGHT.  
CONSULT UTILITY IF YOU NEED MORE INFORMATION.

NOTE:  
CUSTOMER ASSUMES RESPONSIBILITY TO SUBMIT DRAWINGS FOR POWER CO. APPROVAL.

**NES**  
NELCO ELECTRICAL SUPPLY, INC.  
NelcoElectricalSupply.com | 209.699.3049  
232 W. Larch Rd. Suite A Tracy, CA 95304

DRAWN BY: J.M	DATE: 1/31/24	TITLE: MSBDS (1600A)
APPROVED BY:	DATE:	1600A 208Y/120V 3ø 4W 100KA CU OUTDOOR
REVIEWED BY:	DATE:	DISTRIBUTOR: NELCO CONTRACTOR: TBD DWG. NO: 10200-1 SCALE: 1"=1'-0" SHEET: 1 OF 2

REV.	DATE	DESCRIPTION	BY	REV.	DATE	DESCRIPTION	BY

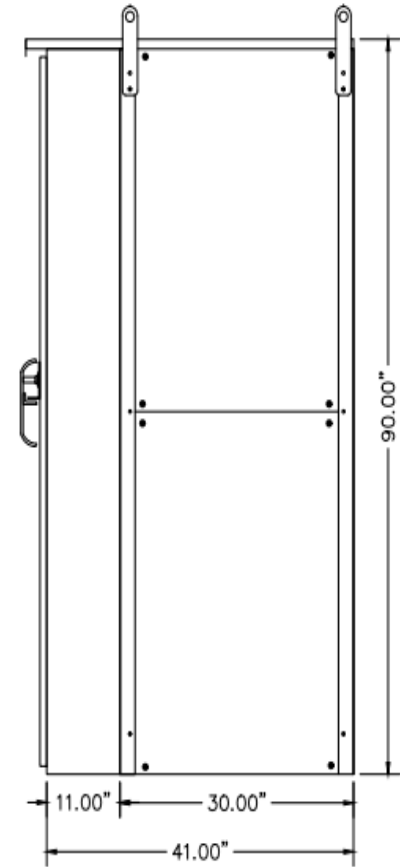
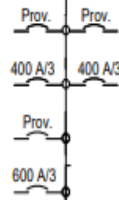
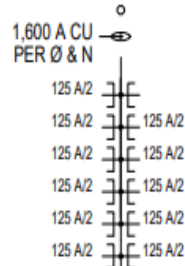
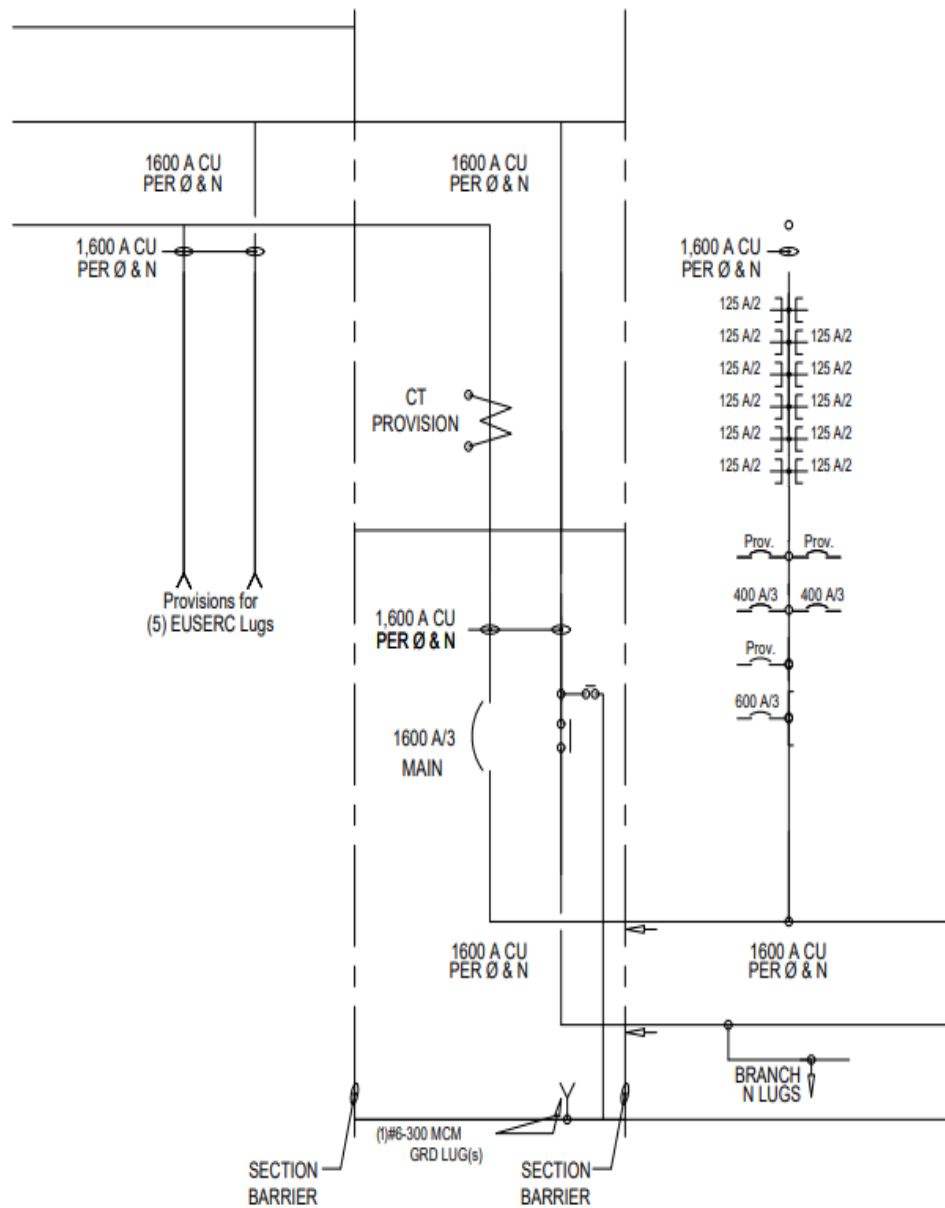

**NES**  
**NELCO ELECTRICAL SUPPLY, INC.**  
 NelcoElectricalSupply.com | 209.699.3049  
 232 W. Larch Rd. Suite A Tracy, CA 95304

REV.	DATE	DESCRIPTION	BY	REV.	DATE	DESCRIPTION	BY

DRAWN BY: J.M. APPROVED BY: REVIEWED BY:	DATE: 1/31/24 DATE: DATE:	TITLE: MSBDS (1600A) 1600A 208Y/120V 3Ø 4W 100KA CU OUTDOOR DISTRIBUTOR: CONTRACTOR: DOWNS NO.: NELCO TBD 10200-1 EXHIBIT A-1 Page 6 of 2	REV:
--	---------------------------------	---	------

SECTION # 1  
2500A SUPPLY  
2500A SECTION

SECTION # 2  
2500A SUPPLY  
2500A SECTION

SECTION # 3  
2500A SUPPLY  
2500A SECTION

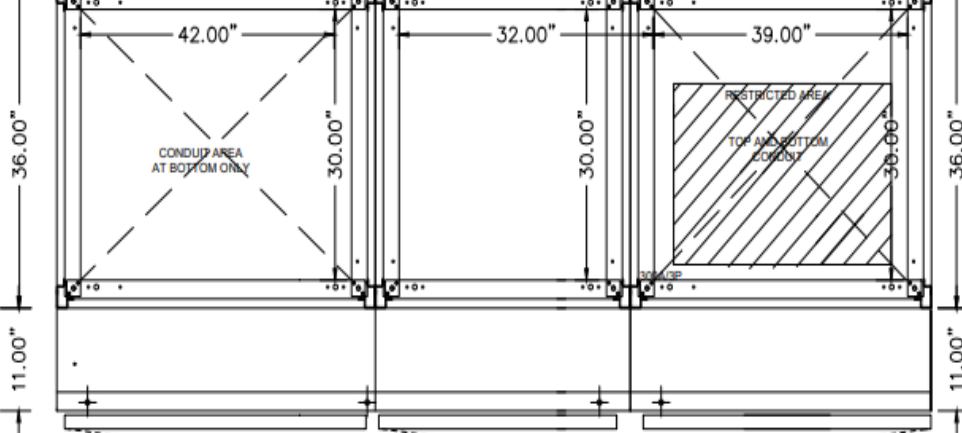
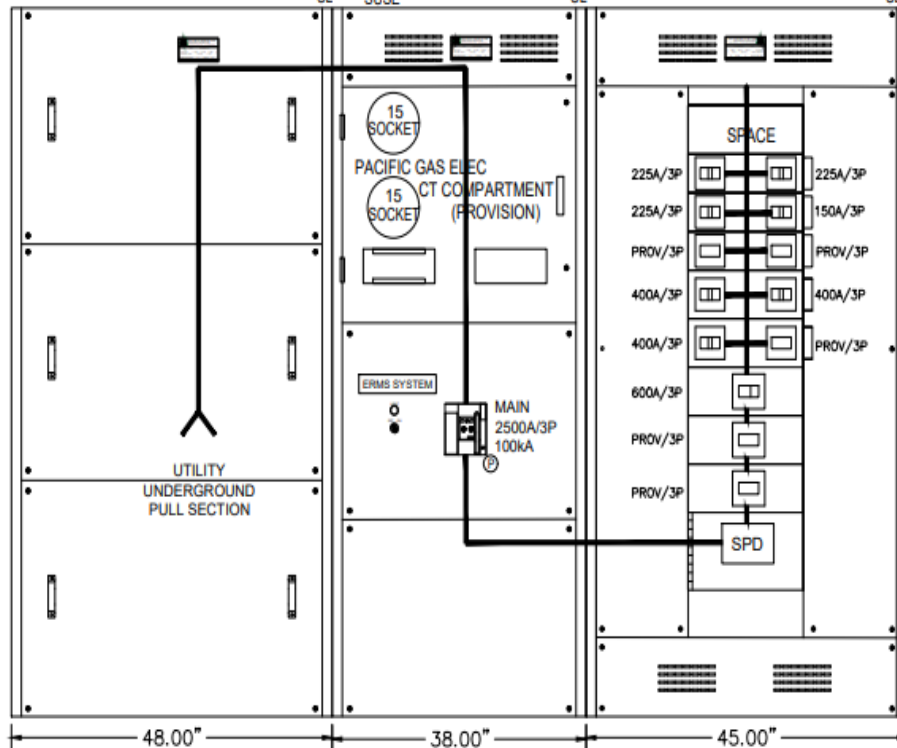

**GENERAL NOTES:**

**SYSTEM:**

- 1.-SERVICE TO BE: 208Y/120V 3PH 4W 2500A AND BRACED FOR 100KAIC.
- 2.-BUS TO BE SILVER PLATED COPPER
- 3.-SERVICE ENTRANCE EQUIPMENT.
- 4.-EQUIPMENT TO BEAR UL 891 LABEL.
- 5.-CONSTRUCTION TO COMPLY WITH THE LATEST IEEE, NEMA, UL, AND ALL APPLICABLE INDUSTRY STANDARDS.

**ENCLOSURE OUTDOOR CONSTRUCTION:**

- 6.-ENCLOSURE TYPE 3R CONSTRUCTION MADE OF FORMED CODE 14GA WITH A FINISH COAT OF ANSI #61 LIGHT GRAY.
- 7.-ENCLOSURE PAINT FINISH EXTERIOR GRAY POWDER COAT 2000 Hr. SST, MINIMUM 3 MILLS DFT
- 8.-EXTERIOR DOORS TO HAVE 3 POINT LATCHING MECHANISM, PROVISIONS FOR TWO PARTY PADLOCKING AND TO HAVE PROVISIONS TO LATCH OUTDOOR OPEN MINIMUM 90°

**SERVICE:**

UTILITY CO. : PACIFIC GAS ELEC	
-	
-	
-	
DESCRIPTION	PG NO.
CT COMPARTMENT	P322
UGPS	345
LINE TERMINATION	347
METER PLATES	333, 354
SMM METERING	-

INSTALLATION NOTE:  
CAUTION: IF SWITCHBOARD IS INSTALLED ON A HOUSEKEEPING SLAB GRATER THAN 2-1/2" THE METER MAY BE OVER THE 6"3" MAXIMUM ALLOWABLE METER HEIGHT.  
CONSULT UTILITY IF YOU NEED MORE INFORMATION.

NOTE:  
CUSTOMER ASSUMES RESPONSIBILITY TO SUBMIT DRAWINGS FOR POWER CO. APPROVAL.

**NES**  
NELCO ELECTRICAL SUPPLY, INC.  
NelcoElectricalSupply.com | 209.699.3049  
232 W. Larch Rd. Suite A Tracy, CA 95304

REV.	DATE	DESCRIPTION	BY	REV.	DATE	DESCRIPTION	BY

TITLE: MSBDN (2500A)	DATE: 1/31/24
DRAWN BY: J.M	DISTRIBUTOR: NELCO
APPROVED BY:	CONTRACTOR: TRD
REVIEWED BY:	DWG. NO. 10200-2
SCALE: 1/8" = 1'-0"	SHEET: 1 OF 2

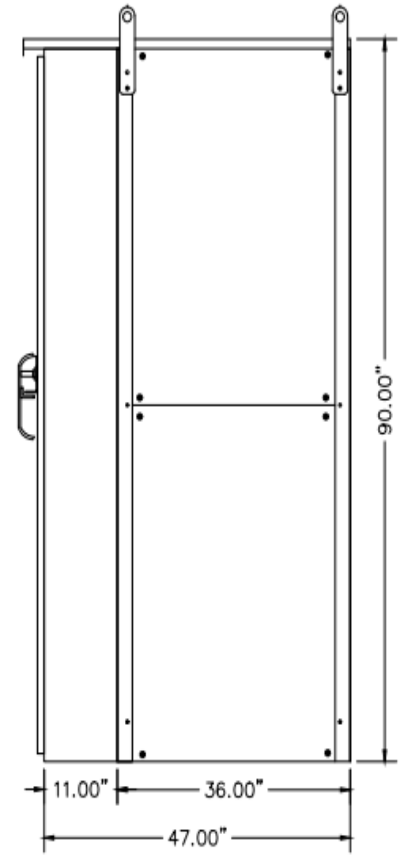
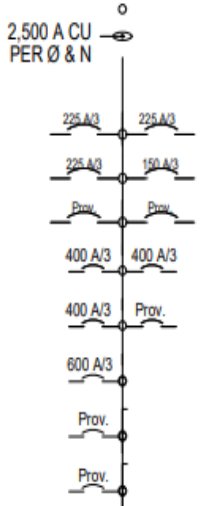
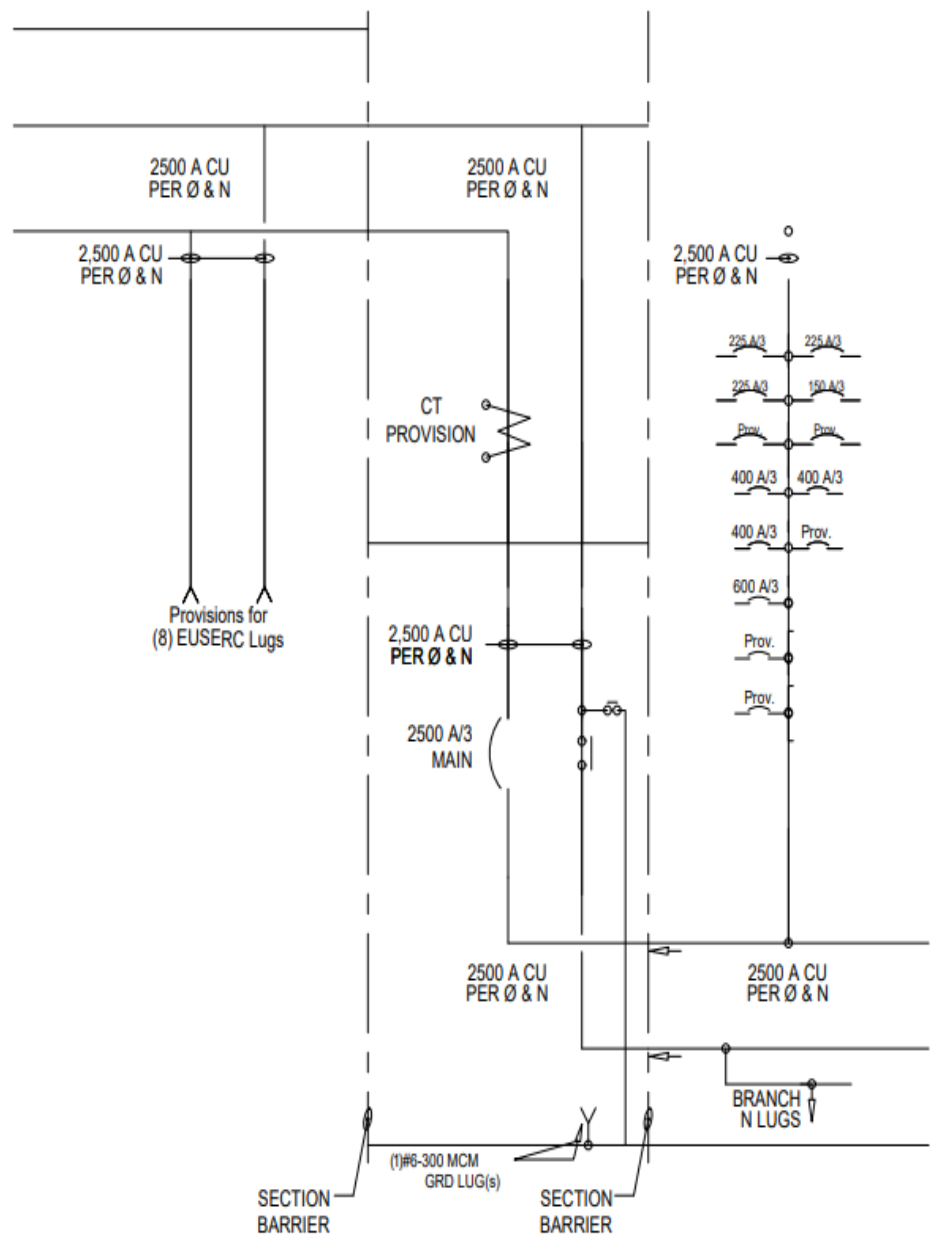

**NES**  
**NELCO ELECTRICAL SUPPLY, INC.**  
 NelcoElectricalSupply.com | 209.699.3049  
 232 W. Larch Rd. Suite A Tracy, CA 95304

REV.	DATE	DESCRIPTION	BY	REV.	DATE	DESCRIPTION	BY

DRAWN BY: J.M	DATE: 1/31/24	TITLE: MSBDN (2500A)
APPROVED BY:	DATE:	2500A 208Y/120V 3Ø 4W 1000A CU OUTDOOR
REVIEWED BY:	DATE:	DISTRIBUTOR CONTRACTOR ENG. NO. NELCO TBD 10200-2

SECTION # 1  
600A SUPPLY  
600A SECTION

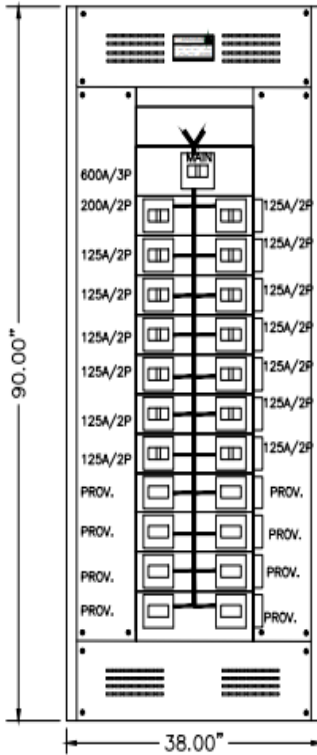

FRONT VIEW

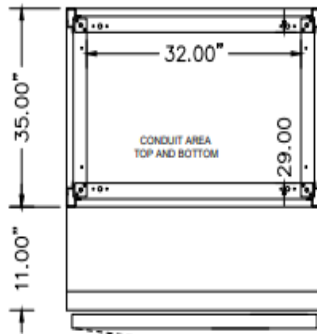

PLAN VIEW

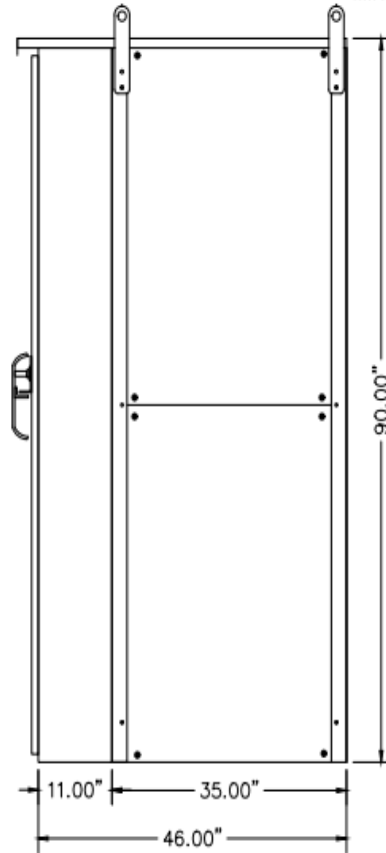

**GENERAL NOTES:**

**SYSTEM:**

- 1.-SERVICE TO BE: 208Y/120V 3PH 4W 600A AND BRACED FOR 65kAIC.
- 2.-BUS TO BE SILVER PLATED COPPER.
- 3.-EQUIPMENT TO BEAR UL 891 LABEL.
- 4.-CONSTRUCTION TO COMPLY WITH THE LATEST IEEE, NEMA, UL, AND ALL APPLICABLE INDUSTRY STANDARDS.

**ENCLOSURE OUTDOOR CONSTRUCTION:**

- 5.-ENCLOSURE TYPE 3R CONSTRUCTION MADE OF FORMED CODE 14GA WITH A FINISH COAT OF ANSI #61 LIGHT GRAY.
- 6.-ENCLOSURE PAINT FINISH EXTERIOR GRAY POWDER COAT 2000 Hr. SST, MINIMUM 3 MILLS DFT



NELCO ELECTRICAL SUPPLY, INC.  
NelcoElectricalSupply.com | 209.699.3049  
232 W. Larch Rd. Suite A Tracy, CA 95304

DRAWN BY: J.M		DATE: 1/31/24	TITLE: SP3 (600A)	
APPROVED BY:		DATE:	600A 208Y/120V 3P 4W 65KA CU OUTDOOR	
REVIEWED BY:		DATE:	DISTRIBUTION: NELCO	CONTRACTOR: TBD
			SCALE: 10200-3	REV. 1

REV.	DATE	DESCRIPTION	BY	REV.	DATE	DESCRIPTION	BY





100A, 3P, 240V, 4W, GD DT TYPE 3R

General technical data	
mechanical service life (operating cycles) typical	10000
fastening method	SURFACE
number of poles	3
suitability for operation	LOAD TRANSFER BETWEEN POWER SOURCES
Electricity	
ampacity	100 A
Environmental conditions	
ambient temperature during operation maximum	85 °C
ambient temperature during operation minimum	-29 °C
Model	
product brand name	SIEMENS
product sub brand name	VBII
product type designation	GENERAL DUTY DOUBLE THROW SWITCH
type of electrical connection	MECHANICAL LUGS
Mechanical Design	
design of the housing	TYPE 3R
design of the actuating element	DOUBLE THROW
material	STEEL
General product approval	
certificate of suitability	UL98

last modified:

9/15/2021 



# SIEMENS

## Proposal

- 1 - 150A /2P-QRH2
  - 1 - Catalog #: QRH22B150
  - Enclosure, Catalog Number NR74
  - 1 - NR TYPE 3R ENCL ASSY-74HX5.75D, 20 WIDE

### Global Notes:

### Important Update:

As a result of the global Covid-19 Virus outbreak, temporary delays in delivery, labor or services from Siemens and its sub-suppliers or subcontractors may occur. Among other factors, Siemens' delivery is subject to the correct and punctual supply from sub-suppliers or subcontractors, and Siemens reserves the right to make partial deliveries or modify its labor or services. While Siemens shall make every commercially reasonable effort to meet the delivery or service or completion date mentioned above, such date is subject to change and buyer shall not be entitled to any damages resulting from such delays.

### Cancellation Schedule:

In the event that Buyer cancels the purchase order, or portions of the purchase order in writing, the following charges, as a percentage of the total purchase order price for the order, or application portions thereof, will apply:

After receipt of order or before approval drawings are completed	15%
After approval drawing completion, but before release to manufacturing	30%
Before start of fabrication, but after major component purchase	60%
After start of fabrication, but before start of assembly	80%
After assembly has started	100%

**Price Policy:** Standard quote is valid for 30 days from price approval date.

**Hold for Release Pricing:** Unless Siemens has agreed with the customer in writing, in advance to fixed pricing for an extended release date, any orders entered into COMPAS that have not been released by the customer within 90 days shall be subject to a price increase reflecting the current pricing at time of release. If Buyer refuses to accept price increase Siemens shall reserve the right to cancel the order.

**Shipping:** Shipment of goods will be made after receipt of all the following at Company's production facility:  
(a) Purchase Order / Electronic PO, (b) Technical Information, and if required (c) Drawing Approval.

**Freight:** Freight allowed on all orders over \$1,000 and shipped within the contiguous United States, provided Seller selects the Route Option: BESTRT -Best Route.

**Delivery:** FOB Shipping Point, unless stated otherwise.

**Small Order Handling:** Purchase orders below \$400 will incur a \$25 Small Order Handling (SOH) Fee.

**Warranty:** Warranty shall be in effect for a period of (1) year from initial operation of the goods but not more than eighteen (18) months from Siemens, shipment of the goods, unless stated otherwise.

**Payment:** Per Siemens distributor's terms. For orders \$3,000,000 or greater, the payment shall be according to the following schedule unless stated elsewhere in the proposal:

Upon receipt of purchase order	20%
--------------------------------	-----

# SIEMENS

Attention: NELCO ELECTRICAL

Job Name: N3R PANEL 021324 NELCO ELECTRIC  
Quote Name: N3R PANEL 021324 NELCO ELECTRIC  
Quote #: phe1rx00c\_02132401\_00\_00\_M00  
Bid Date: 02/13/2024

Siemens Industry, Inc. (Company) agrees to sell to Purchaser and Purchaser agrees to purchase from the Company the goods described below. Written quotations are valid for 30 calendar days from price approval date unless otherwise stated in the quotation. Quotations are subject to change by Siemens Industry, Inc. at any time upon written notice to Purchaser. Estimated Lead times refer to the manufacturing cycles, in working days, at time of quotation and are subject to change.

Quote Notes:

Line #:	Qty	Description
20000	1	<b>PANEL 400A 3R 208V--PANELBOARD P2</b> 1 - SECTION P2C42JX400FTS, System Voltage: 208Y/120 3Ø 4W Wye AC, 1R @ 22,000 AIC, Top Feed, Surface Mount, Bus Rating: 400A, Bus Material: Copper, Plating: Tin, NEMA 3R OUTDOOR. 1 - INTERIOR W/ 400A /3P-JXD6 MAIN BREAKER 1 - Mech Lugs (2)3/0-500Kcmil Cu/ 4/0-500 Al 1 - (2)3/0-500Kcmil Cu/ 4/0-500 Al 1 - No Front 1 - Certification - UL 1 - Std Al/Cu Gnd Connector 1 - Catalog #: JXD63B400 1 - 70A /3P-BLH 1 - Catalog #: B370H 1 - 15A /2P-BLH 1 - Catalog #: B215H 2 - 20A /1P-BLH 1 - Catalog #: B120H 18 - 1P-BLH - PROV 5 - BL/BQD PROVISION 2 - 125A /2P-QRH2 1 - Catalog #: QRH22B125

PANELBOARD NOTES

SECTION :1 OF 1  
 PANEL TYPE :P2  
 CATALOG NUMBER :P2C42JX403FTS  
 ENCLOSURE :3R Outdoor  
 SYSTEM VOLTAGE :288Y/120 3Ø 4W Wye AC  
 IR RATING :22 K AIC  
 MAIN BUS :400 A  
 BUS MATERIAL :Tin Plated Copper  
 FEED :Top  
 MOUNTING :Surface  
 SE LABEL :No  
 SERIES RATED :No  
 CONDUIT AREA :N/A  
 \*INDICATES POSITIONING NUMBERS TO HELP WITH THE MANUAL PLACEMENT OF BREAKERS ON THE MECHANICAL VIEW

(2)3/0-500KCMIL CU/ 4/0-650 AL/PH AND N



ABBREVIATIONS

\*PROV\* PROVISION FOR FUTURE DEVICE

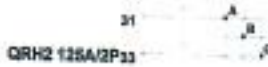

N3R PANEL 021324 NELCO ELECTRIC

CL	CL
PHALX50c	PHALX50c
2-13-2024	2-13-2024
PHALX50c_02132401_00_00_M00-20000-2	PHALX50c_02132401_00_00_M00-20000-2
Siemens Industry, Inc.	Siemens Industry, Inc.



PANELBOARD NOTES

SECTION :1 OF 1  
 PANEL TYPE :P2  
 CATALOG NUMBER :P2C42JX480PTS  
 ENCLOSURE :SR Outdoor  
 SYSTEM VOLTAGE :208Y/120 3Ø 4W Wye AC  
 IR RATING :22 K AIC  
 MAIN BUS :400 A  
 BUS MATERIAL :Tin Plated Copper  
 FEED :Top  
 MOUNTING :Surface  
 SE LABEL :No  
 SERIES RATED :No  
 CONDUIT AREA :N/A  
 \*INDICATES POSITIONING NUMBERS TO HELP WITH THE MANUAL PLACEMENT OF BREAKERS ON THE MECHANICAL VIEW

MAIN  
 JXD6  
 400A/3P

PANELBOARD COMPONENTS

Main :  
 1 - 400A 3P-JXD6 MAIN BREAKER

Branches :  
 1 - 75A 2P-BLH  
 1 - 15A 2P-BLH  
 2 - 25A 1P-BLH  
 18 - 1P-BLH - PROV  
 5 - BL/BQD PROVISION  
 2 - 125A 2P-QRH2  
 1 - 150A 2P-QRH2

Options :  
 1-No Front  
 1-AL/Cu Branch Connector  
 1-Certification - UL  
 1-8id Al/Cu Gnd Connector

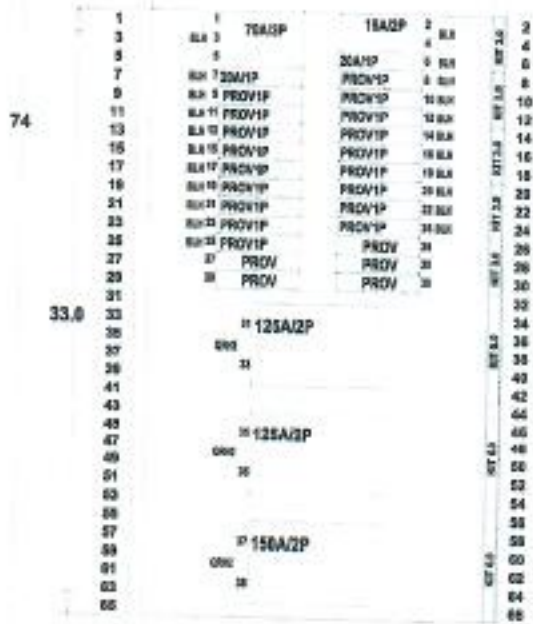

5.75 Deep 20.0

N3R PANEL 021324 NELCO ELECTRIC

NO.	0	DATE	2-13-2024
DESIGNER	phelrx00c	DATE	2-13-2024
CHECKED	phelrx00c	DATE	2-13-2024
APPROVED	phelrx00c	DATE	2-13-2024
PROJECT	PANEL 400A 3R 208V		
DESCRIPTION	PANEL 400A 3R 208V		
REV.	1	DATE	2-13-2024
BY	phelrx00c	DATE	2-13-2024
CHECKED	phelrx00c	DATE	2-13-2024
APPROVED	phelrx00c	DATE	2-13-2024

NO.	REVISIONS	DRAWN BY	DATE
1	0	phelrx00c	2-13-2024

Siemens Industry, Inc.  
 Norcross, Georgia

Nelco Electrical Supply Inc.  
 232 W. Larch Rd. Suite A  
 Tracy, CA 95304  
 sales@nelcoelectricalsupply.com  
 www.nelcoelectricalsupply.com



## Estimate

### ADDRESS

City of Tracy  
 520 Tracy Blvd  
 Tracy, Ca 95376

### SHIP TO

City of Tracy  
 520 Tracy Blvd  
 Tracy, Ca 95376

ESTIMATE # 1053

DATE 01/31/2024

ACTIVITY	DESCRIPTION	QTY	RATE	AMOUNT
custom order gear	2500 Amp 120/208v 3P 4W CU N3R 100kA PGE meter service entrance 3 Sections 1- main breaker 2500/3 1- SPD 400kA 1- 600/3 3- 400/3 4- 225/3	1	152,697.22	152,697.22T
custom order gear	1600 Amp 120/208v 3P 4W CU N3R 100kA PGE meter service entrance 3 Sections 1- main breaker 1600/3 1- 600/3 2- 400/3 1- 225/3 11- 125/3 1- 70/3	1	134,297.82	134,297.82T
custom order gear	600 Amp 120/208v 3P 4W CU N3R 65kA Distribution board 1- 600/3 1- 200/3 13- 125/3	1	33,692.01	33,692.01T
shipping	freight to be paid by the COT. Shipping charges will be added once items are ready to ship	1	0.00	0.00T

50% down to start the job, remainder due at delivery.  
 12-14 week lead time after PO and payment is received  
 no returns, no cancellations  
 all products are new and come with a two year warranty

SUBTOTAL	320,687.05
TAX	26,456.68
<b>TOTAL</b>	<b>\$347,143.73</b>

Nelco Electrical Supply Inc.  
 232 W. Larch Rd. Suite A  
 Tracy, CA 95304  
 sales@nelcoelectricalsupply.com  
 www.nelcoelectricalsupply.com



## Estimate

**ADDRESS**

City of Tracy  
 520 Tracy Blvd  
 Tracy, Ca 95376

**SHIP TO**

City of Tracy  
 520 Tracy Blvd  
 Tracy, Ca 95376

**ESTIMATE #** 1054

**DATE** 02/13/2024

ACTIVITY	DESCRIPTION	QTY	RATE	AMOUNT
circuit breaker	400 AMP 120/208V 3P 4W 22KAIC N3R TOP FED COPPER 1- JXD63B400 1-B370H 1-B215H 2-B120H 2-QRH22B125 1-QRH22B150	1	11,246.54	11,246.54T
circuit breaker	MTS 100 AMP 120/208V 3P 4W NON FUSED N3R DTGNF323NR	1	1,544.01	1,544.01T

Items are in stock at this time, inventory subject to change  
 2-4 days build time  
 estimated delivery dates not guaranteed.

SUBTOTAL 12,790.55  
 TAX 1,055.22  
**TOTAL \$13,845.77**

Accepted By

Accepted Date



March 4, 2024

City of Tracy  
520 Tracy Blvd.  
Tracy, CA 95376

- Submittals:
  - 1 2500 amp 120/208v 3p 4w 100kaic n1 3 section meter cabinet
  - 1 1600 amp 120/208v 3p 4w 100kaic n1 3 section meter cabinet
  - 1 600 amp 120/208v 3p 4w 65kaic n1 single section distribution board
  - Final manufacturers bill of materials and plans to be submitted for Engineer approval.
- Delivery Specification:
  - COT is to pay the freight to have the items shipped FOB factory, on a private carrier and the freight cost is TBD.
- Payment Details:
  - 50% is due to start the custom build boards. The remainder of the balance is due upon completion. There is no cancellation allowed once the deposit is made. For any reason COT is to cancel the order full payment will be required.
  - 40% is due upon delivery of the equipment to the Vendor's location.
  - 10% is due upon City acceptance that the Goods comply with the requirements of Exhibit A and the approved plans and specifications.
- Build Time:
  - 14 weeks from the Monday following the deposit date. If for any reason we do not meet our deadline, at the end of the 15<sup>th</sup> week we will refund the city of Tracy 5% every week past the deadline. The metered cabinets will be completed by Nelco Electrical Supply in 14 weeks, guaranteed.
- Warranty provided by Nelco Electrical Supply:
  - The Vendor warrants that the Equipment was constructed in accordance with the approved plans and specifications and is free from defects. If the equipment fails or malfunctions within the Warranty period, the manufacturer will repair or replace at no cost to the City for two years from the date of delivery on all items sold.
  - The Vendor warrants that all Equipment meets PG&E requirements for service entrance.

TRACY CITY COUNCIL

RESOLUTION NO. \_\_\_\_\_

---

**DETERMINING THAT COMPLIANCE WITH THE STANDARD PROCUREMENT PROCESS IS NOT IN THE BEST INTEREST OF THE CITY PURSUANT TO CALIFORNIA PUBLIC CONTRACT CODE SECTION 20301 AND TRACY MUNICIPAL CODE SECTION 2.20.180(B)(4), AND (2) APPROVING A PURCHASE AGREEMENT WITH NELCO ELECTRICAL SUPPLY, INC., IN THE AMOUNT OF \$391,636.58, FOR THE PURCHASE OF ELECTRICAL EQUIPMENT REQUIRED FOR PERMANENT POWER SUPPLIES.**

**WHEREAS**, on March 10, 2020, City Council adopted Resolution No. 2020-050, which declared a shelter crisis pursuant to California Government Code Section 8698.2; and

**WHEREAS**, on September 1, 2020, City Council authorized the creation of a Capital Improvement Project (CIP) for the Temporary Emergency Housing Project on Arbor Avenue, CIP 71112 (Project) to create a safe and dignified facility for residents experiencing homelessness; and

**WHEREAS**, Phase I of the Project, demolition of the existing structures, site and preparation, and underground utilities began in May of 2022. Phase II of the Project, the Site Improvements including the Sprung Structure, were delayed due to funding; and

**WHEREAS**, the Phase III Interim Project facility was opened in December of 2022, housing up to 48 individuals in leased modular structures; and

**WHEREAS**, A permanent power supply was in the proposed Phase II Project construction, but that Phase was postponed due to the costs related to expediting the completion of the interim facility preparation; as a result, Portable generators were leased to provide power for the site until equipment for a permanent power supply could be installed; and

**WHEREAS**, on July 5, 2023, City Council authorized the purchase of eight (8) custom container dormitories under Resolution 2023-140, to be installed as part of the Phase IV interim shelter facility improvements; The Phase IV Interim Project facility was opened in December of 2023, providing housing for an additional 38 individuals; and

**WHEREAS**, in April of 2023, City Engineering staff issued a Notice Inviting Bidders for two permanent power supply construction contracts, separately from the facility site improvements, to expedite the procurement and installation of the electrical equipment that had a thirty-seven (37) week lead time; In May of 2023, bids were received from two contractors for each power supply, and one contractor was the low bidder on both contracts; The contract was awarded to the low bidder for both projects by Council on July 05, 2023; The low bidder failed to submit correctly completed construction contract documents as required, was determined to be non-responsive, and all bids were rejected December of 2023; and



**WHEREAS**, staff and the project design consultants began contacting multiple vendors in December of 2023, requesting quotes for purchasing the necessary permanent electrical equipment, and if possible, expedited delivery; Quotes were received from four vendors; and

**WHEREAS**, only one vendor (Nelco) was able to provide expedited delivery; The three other vendors were not able to offer that option, primarily due to shortages and long lead times on the high voltage components require; and

**WHEREAS**, both Phase III and Phase IV interim housing facilities are now being powered by four (4) portable generators, consisting of two (2) primary generators and two (2) backup generators, required by South San Joaquin County Fire to maintain power to the Fire Alarm Monitoring System; Fuel costs have increased due to the higher demand of the additional facilities and residents; and

**WHEREAS**, the monthly costs for providing power to the Interim facilities, including the generator rental costs and fuel to operate the equipment 24/7 is averaging approximately \$91,000 per month and there are two viable options for moving forward with the direct purchase of the electrical equipment; and

**WHEREAS**, staff has reviewed both the initial cost of the equipment versus the ongoing operating costs and concluded that Option 1 has the most benefit to the City based on the savings of operations; Although Nelco was not the “lowest” responsible bidder as required under a strict reading of TMC 2.20.180, in terms of costs saved by the City by Nelco’s relatively expedited delivery time, Nelco’s bid offers the greatest net-savings for the City; and

**WHEREAS**, pursuant to California Public Contract Code Section 20301 and Tracy Municipal Code Section 2.20.180(b)(4) states that exceptions to standard procurement process is allowable when it is not in the best interest of the City; and

**WHEREAS**, the fiscal impact of the Temporary Emergency Homeless Shelter, CIP 71112, is an approved project in the City’s Capital Improvement Plan and sufficient funds are available in the project for the purchase of the equipment, and the current project budget; and

**WHEREAS**, the Tracy Homelessness Advisory Committee heard this item on March 21, 2024 and recommended that the City Council adopt the proposed Resolution; and

**NOW THEREFORE**, be it

**RESOLVED:** That the City Council for the City of Tracy hereby finds the actions approved by this resolution exempt from California Environmental Quality Act (CEQA) pursuant to Government Code section 8698.4 as provided for homeless shelters; and be it further

**RESOLVED:** That the City Council for the City of Tracy hereby determines that strict compliance with the standard procurement process for the Goods Purchase Agreement with Nelco Electrical Supply, Inc. is not in the best interest of the City pursuant to California Public Contract Code Section 20301 and Tracy Municipal Code Section 2.20.180(b)(4); and be it further

**RESOLVED:** That the City Council hereby approves Goods Purchase Agreement with Nelco Electrical Supply, Inc. for purchase of electrical supply equipment in the amount of \$391,636.58 to be utilized at the Temporary Emergency Housing Facility, CIP 71112, at 370 Arbor Avenue, attached hereto as Attachment 1; and be it further

**RESOLVED:** that the Mayor is authorized to execute the Goods Purchase Agreement with Nelco Electrical Supply, Inc. at the Temporary Emergency Housing Facility, CIP 71112, at 370 Arbor Avenue, attached hereto as Attachment 1.

\*\*\*\*\*

The foregoing Resolution 2024-\_\_\_\_\_ was adopted by the City Council on April 2, 2024, by the following vote:

AYES:	COUNCIL MEMBERS:
NOES:	COUNCIL MEMBERS:
ABSENT:	COUNCIL MEMBERS:
ABSTENTION:	COUNCIL MEMBERS:

\_\_\_\_\_  
NANCY D. YOUNG  
Mayor of the City of Tracy, California

ATTEST: \_\_\_\_\_  
ADRIANNE RICHARDSON  
City Clerk and Clerk of the Council of the  
City of Tracy, California

Attachments:

- (1) Goods Purchase Agreement – Nelco Electrical Supply, Inc.