

# TITLE 24

## RESIDENTIAL LIGHTING DESIGN GUIDE

Best practices and lighting designs to help builders comply with California's *2008 Title 24 Building Energy Efficiency Standards*





## MESSAGE FROM SPONSORS

The changes to California's *2008 Title 24 Building Energy Efficiency Standards* represent a significant opportunity for increased energy savings and reduced maintenance. However, these changes also present new challenges for builders and installation professionals with demands for improved technology and higher energy efficiency.

The *2008 Title 24, Part 6* revisions were developed through a consensus process, incorporating changes that require minimal disruption to current practice. Considering this collaborative approach and the potential for implementation challenges, a consortium representing broad interests developed this design guide for the builder community.

The *Residential Lighting Design Guide* provides a practical approach to lighting code compliance and design, including a broad array of example designs as well as technical and compliance information organized in a step-by-step format. The guide aims to assist in the process of developing compliant, high-quality lighting designs.

This guide will greatly help the building community deliver high-performance, energy-efficient lighting systems to homeowners in a cost-effective manner.

### SPONSORS:

California Energy Commission  
Public Interest Energy Research (PIER)  
Sacramento Municipal Utility District  
WattStopper

### SPECIAL THANKS:

The *Residential Lighting Design Guide* was developed by the California Lighting Technology Center, with special thanks to Erik Jensen and Gary Flamm from the California Energy Commission and Connie Samla from Sacramento Municipal Utility District for their contributions.



# TABLE OF CONTENTS

## INTRODUCTION

<i>2008 Title 24 Building Energy Efficiency Standards</i>	4
About this Guide	5

## TECHNOLOGY OVERVIEW

Certification to the Energy Commission	8
Two Key Strategies	9
Luminaires	10
Switching Controls	15
Vacancy Sensors	16
Dimmers	18
Other Control Devices	20
Purchase & Selection	21

## LIGHTING DESIGN GUIDE

<i>Title 24, Part 6 Changes</i>	24
Introduction to Lighting Design	26
■ Kitchens	27
■ Bathrooms, Garages, Closets, Laundry Rooms, & Utility Rooms	30
■ Other Rooms	33
■ Outdoor Lighting	37
■ Multi-family Common Areas	41
■ Parking Lots & Garages	42

## APPENDIX

Compliance Checklist	44
Glossary	49
Resources & Information	53





# 2008 TITLE 24 BUILDING ENERGY EFFICIENCY STANDARDS

The California Energy Commission adopted the *2008 Title 24 Building Energy Efficiency Standards* on April 23, 2008, and the Building Standards Commission approved them for publication on September 11, 2008. The *2008 Residential Compliance Manual* was adopted by the Energy Commission on December 17, 2008. If an application for a building permit is submitted on or after January 1, 2010, the 2008 standards must be met.

The Energy Commission adopted the changes to the 2008 standards for a number of reasons:

1. To provide California with an adequate, reasonably priced, and environmentally sound supply of energy.
2. To respond to Assembly Bill 32, the Global Warming Solutions Act of 2006, which mandates that California reduce its greenhouse gas emissions to 1990 levels by 2020.
3. To pursue California energy policy that promotes energy efficiency as the resource of first choice for meeting California's energy needs.
4. To act on the findings of California's Integrated Energy Policy Report that standards are the most cost-effective means to achieve energy efficiency. The *2008 Title 24 Building Energy Efficiency Standards* are expected to continue to be upgraded over time to reduce electricity and peak demand, while recognizing the role of the standards in reducing energy related to meeting California's water needs and in reducing greenhouse gas emissions.
5. To meet the West Coast Governors' Global Warming Initiative commitment to include aggressive energy-efficiency measures into updates of state building codes.
6. To meet the Executive Order in the Green Building Initiative to improve the energy efficiency of nonresidential buildings through aggressive standards.

# ABOUT THIS GUIDE

The *Title 24 Residential Lighting Design Guide* was sponsored by the California Energy Commission and developed by the California Lighting Technology Center at UC Davis.

This guide is intended to be used as a supplement for the *2008 Residential Compliance Manual*. It is a resource to help contractors, designers, and builders understand the *2008 Title 24 Building Energy Efficiency Standards* and how to integrate these changes into new home plans. This guide consists of two key sections: the Technology Overview and the Lighting Design Guide.

## TECHNOLOGY OVERVIEW

The Technology Overview describes the technologies that are essential for compliance with *2008 Title 24, Part 6*, as well as suggestions on how to use them throughout a residential building. This section includes specifications for manufacturing *Title 24, Part 6*-compliant technologies.

## LIGHTING DESIGN GUIDE

The Lighting Design Guide demonstrates ways to meet the new code requirement with high-efficacy lighting design plans for rooms specified in *Title 24, Part 6*. It also indicates the lighting standards for each room and offers helpful tips and explanations for each lighting design depicted.

### CLTC TITLE 24, PART 6 RESOURCES

[cltc.ucdavis.edu/title24](http://cltc.ucdavis.edu/title24)

---

**Note: This guide is not intended to be used in lieu of the *Title 24, Part 6* code.**

Please visit [www.energy.ca.gov/title24](http://www.energy.ca.gov/title24) to download the official *2008 Title 24 Building Energy Efficiency Standards* as well as the *Residential Compliance Manual*. To obtain a hard copy of the standards, contact the California Energy Commission's publications unit at (916) 654-5200.





# TECHNOLOGY OVERVIEW

<b>Certification to the Energy Commission</b>	<b>8</b>
<b>Two Key Strategies</b>	<b>9</b>
<b>Luminaires</b>	<b>10</b>
<b>Switching Controls</b>	<b>15</b>
<b>Vacancy Sensors</b>	<b>16</b>
<b>Dimmers</b>	<b>18</b>
<b>Other Control Devices</b>	<b>20</b>
<b>Purchase &amp; Selection</b>	<b>21</b>

# CERTIFICATION TO THE ENERGY COMMISSION

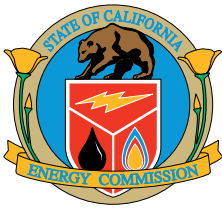

## APPLIANCE EFFICIENCY DATABASE

[www.appliances.energy.ca.gov](http://www.appliances.energy.ca.gov)

Light emitting diode (LED) luminaires must be certified by the manufacturer to the Energy Commission to receive a high-efficacy classification. LED luminaires not certified to the Energy Commission shall be classified as low efficacy. Lighting controls used to achieve *Title 24, Part 6* compliance also must be certified by the manufacturer to the Energy Commission.

### FINDING A CERTIFIED DEVICE

For a current list of lighting devices approved by the Energy Commission, visit the online Appliance Efficiency Database at [www.appliances.energy.ca.gov](http://www.appliances.energy.ca.gov). This database is maintained by the Energy Commission and includes all appliances, devices, and controls that have been certified to the Energy Commission. Appliances listed in the database either meet federal efficiency standards or, where there are no federal efficiency standards, meet California's appliance efficiency standards.

### CERTIFYING A PRODUCT TO THE ENERGY COMMISSION

Manufacturers of devices regulated by *Title 24, Part 6* must certify the devices by completing the appropriate certification forms from the Energy Commission. The forms for lighting devices regulated by *Title 24, Part 6* can be found at [www.energy.ca.gov/appliances/database/forms\\_instructions\\_cert/lighting](http://www.energy.ca.gov/appliances/database/forms_instructions_cert/lighting).

Residential lighting devices that must be certified to the Energy Commission include ballasts for residential recessed luminaires, compact fluorescent lamps (CFLs), fluorescent lamp ballasts, high-efficacy LED luminaires, certain lighting control devices, metal halide luminaires, and undercabinet luminaires.

# TWO KEY STRATEGIES

A combination of energy-efficient luminaires and lighting controls allow builders and designers to create building plans that comply with the *2008 Title 24 Building Energy Efficiency Standards*:

## 1. HIGH-EFFICACY LUMINAIRES

High-efficacy luminaires are designed and built to operate only energy-efficient light sources, such as LED lighting systems, fluorescent T8 or T5 lamps, CFLs, and some high intensity discharge (HID) lamps. For residential buildings, the use of high-efficacy luminaires is preferred over low-efficacy luminaires paired with lighting controls.

## 2. LOW-EFFICACY LUMINAIRES + LIGHTING CONTROLS

Low-efficacy luminaires are allowed throughout *Title 24, Part 6* if they are paired with appropriate lighting controls. Among the most common lighting controls allowed in the code are vacancy sensors and dimmers.

Occupancy sensors, vacancy sensors, and motion sensors are devices that automatically switch the lights in response to the presence or absence of motion in a space. Dimmer switches allow occupants to manually lower the room lighting, and thus the power used, as desired. These controls are allowed as an alternative to high-efficacy luminaires for some *Title 24, Part 6* applications.

This section will explain how these technologies work, what features to look for when purchasing or specifying them, and which applications are most appropriate for each technology. A solid understanding of these technologies is key to *Title 24, Part 6*-compliant lighting designs and specifications.

## LUMINAIRE

A luminaire is the lighting industry's term for a light fixture. A luminaire consists of the housing, lamp (light bulb), power supply (ballast or transformer), reflector, and, in some cases, a lens.

## EFFICACY

**Efficacy = rated lumens / rated watts**

Efficacy is a measure of how much light is produced by a lamp or lighting system per unit of electrical power consumed.

## PERMANENTLY INSTALLED LUMINAIRES

- Lighting attached to walls, ceilings, and columns.
- Track and flexible lighting systems.
- Lighting inside permanently installed cabinets.
- Lighting attached to the top or bottom of permanently installed cabinets.
- Lighting attached to ceiling fans.
- Lighting integral to exhaust fans.
- Lighting integral to garage door openers if designed to be used as general lighting, switched independently from the door opener, and does not automatically turn off.

Permanently installed luminaires do not include portable luminaires (table lamps and floor lamps), lighting in appliances, or lighting in garage door openers consisting of two or fewer screw-base sockets.

# LUMINAIRES

## HIGH-EFFICACY LUMINAIRES

The *Title 24, Part 6* standards require all **permanently installed luminaires** to be high efficacy. A lamp or lighting system must meet efficacy requirements listed in Table 1 and Table 2 to be classified as high efficacy. Additionally, LED lighting source systems must be certified to the Energy Commission to be considered high efficacy. Luminaires that do not meet the requirements are considered low efficacy.

**TABLE 1: HIGH-EFFICACY NON-LED LAMPS**

LAMP POWER	MINIMUM LAMP EFFICACY
≤ 5W	30 lm/W
> 5W – 15W	40 lm/W
> 15W – 40W	50 lm/W
> 40W	60 lm/W

Non-LED lamps include line-voltage incandescent, low-voltage incandescent, fluorescent, HID, and induction lamps. Ballast wattage is not included in the calculation for lamp efficacy, with the exception of kitchen wattage calculations. The rated watts and lumens usually can be found on the lamp packaging or in the manufacturer's catalog.

**TABLE 2: HIGH-EFFICACY LED LIGHTING SYSTEMS**

SYSTEM POWER	MINIMUM SYSTEM EFFICACY
≤ 5W	30 lm/W
> 5W – 15W	40 lm/W
> 15W – 40W	50 lm/W
> 40W	60 lm/W

LED lighting systems include an LED light engine, heat sink, transformers, and power supply devices, most of which consume power. The wattage for the entire system must be taken into account when calculating efficacy. Rated wattage for LED luminaires can be found on the permanent factory-installed label.

## LOW-EFFICACY LUMINAIRES

Any luminaire that does not meet the efficacy standards in Tables 1 and 2 are considered low-eficacy luminaires. In addition, the following conditions define a low-eficacy luminaire:

1. Incandescent lighting, both low voltage and line voltage.
2. Fixtures that contain a medium screw-base socket or line-voltage socket or line-voltage lamp holder capable of accepting a low-eficacy lamp.
3. Track lighting or lighting systems allowing the addition or relocation of luminaires without altering the wiring of the system.
4. Lighting systems with modular components that allow conversion between screw-base and pin-base sockets.
5. Electrical boxes where no electrical equipment has been installed, but which can be used for a luminaire or surface-mounted ceiling fan.
6. LED lighting not certified to the Energy Commission.

Low-eficacy luminaires may be used in conjunction with lighting controls specified for each residential space to comply with *Title 24, Part 6*.

**TABLE 3: LUMINAIRE TYPES**

HIGH-EFFICACY LUMINAIRES	LOW-EFFICACY LUMINAIRES
<p>Luminaires generally considered high efficacy:</p> <ol style="list-style-type: none"> <li>1. Fluorescent lamps with electronic ballasts</li> <li>2. High intensity discharge (HID)</li> <li>3. Induction lighting</li> <li>4. Certified LED systems</li> <li>5. Certified LED trim</li> <li>6. Certified hybrid LED</li> <li>7. Certified GU-24 base</li> </ol>	<p>Luminaires generally considered low efficacy:</p> <ol style="list-style-type: none"> <li>1. Incandescent sockets</li> <li>2. Screw-base CFL</li> <li>3. Interchangeable screw-base/pin-base sockets</li> <li>4. Uncertified LED</li> <li>5. Uncertified GU-24 base</li> <li>6. Mercury vapor (HID)</li> </ol>



© CALIFORNIA LIGHTING TECHNOLOGY CENTER

*Incandescent = low efficacy*



© CALIFORNIA LIGHTING TECHNOLOGY CENTER

*Screw-base CFLs = low efficacy*



© CALIFORNIA LIGHTING TECHNOLOGY CENTER

*Screw-base socket = low efficacy*



LED trim and housing

### LED LIFE SPAN

LED life span is significantly longer than other light sources with an average of 25,000–50,000 hours, thus requiring less maintenance for the luminaire.

## LED LIGHTING SYSTEMS

**LED lighting systems** are a new, high-efficacy option for *Title 24, Part 6*. To be considered a high-efficacy luminaire, an LED lighting system must meet the efficacy requirements provided in Table 1 on page 10, in addition to being certified to the Energy Commission. LED lighting systems that are not certified to the Energy Commission are considered low-efficacy lighting.

### LED Trim Compliance Requirements

An **LED trim** is a one-piece integral unit containing the power supply, transformer, heat sink, and LED circuit board. To qualify an LED trim as high efficacy, the LED trim and housing must meet the following conditions:

1. The trim must be certified to the Energy Commission according to the high-efficacy standards on page 10.
2. The trim must be hardwired directly into the luminaire housing. Wiring may include any kind of midline connector between LED trim and wire ends, but must not include a screw-base socket configuration.
3. The housing must not contain a screw-base socket.
4. No screw-base adaptors may be used.
5. The screw-base attached to a “pig tail” must be cut off and discarded before hardwiring.

### Hybrid LED Luminaire

A **hybrid LED luminaire** is a complete lighting unit consisting of an LED lighting system and another type of light source (incandescent or fluorescent).

For a hybrid LED luminaire to qualify as high efficacy, the LED lighting system must be high efficacy and be certified to the Energy Commission, and the other non-LED light source also must be high efficacy.

If a high-efficacy LED lighting system is combined with a low-efficacy lighting system, the two must be considered separate in residential applications.



© CALIFORNIA LIGHTING TECHNOLOGY CENTER

A high-efficacy hybrid LED luminaire

## ELECTRONIC BALLASTS

Electronic ballasts are commonly used with fluorescent, HID, and induction luminaires. *Title 24, Part 6* specifies that ballasts for fluorescent lamps rated 13W or higher must be electronic (not magnetic) and must have an output frequency of no less than 20 kHz.

## GU-24 BASE AND SOCKET

The GU-24 base is a newly developed **line-voltage** lamp holder and socket configuration. Typically, a luminaire with a line-voltage socket is classified as a low-efficacy luminaire. GU-24 bases and sockets are the only type of line-voltage socket and holder that may be classified as high efficacy.

## GU-24 Compliance Requirements

1. The GU-24 luminaire is rated for use only with high-efficacy lamps or certified LED lighting systems.
2. The luminaire is not a recessed downlight to be used with a CFL.
3. The luminaire does not contain any other type of line-voltage socket or lamp holder.
4. The manufacturer does not make adaptors or modular components to convert the GU-24 socket to any other type of socket or lamp holder.

## NIGHT-LIGHTS AND LIGHTING INTEGRAL TO EXHAUST FANS

Permanently installed night-lights, night-lights integral to permanently installed luminaires, and lighting integral to exhaust fans must meet either of the following conditions:

1. Must contain only one high-efficacy lamp, and must not contain a line-voltage socket or lamp holder.
2. Must be rated to consume no more than 5W, and must not contain a medium screw-base socket.

The lighting that is integral to exhaust fans must be controlled separately from the exhaust fan.

## LINE-VOLTAGE SOCKETS

Line-voltage sockets pair with a variety of screw, pin, and bayonet bases (also called holders). Line-voltage sockets do not include a transformer, ballast, or power supply between the wires connected to the luminaire and the socket. GU-24 line voltage luminaires are the only type of line-voltage luminaire that may be classified as high efficacy under *Title 24, Part 6*.



© CALIFORNIA LIGHTING TECHNOLOGY CENTER

GU-24 base CFL



© CALIFORNIA LIGHTING TECHNOLOGY CENTER

CFL with detachable GU-24 base



© CALIFORNIA LIGHTING TECHNOLOGY CENTER

*Downlights in a residential kitchen*



© CALIFORNIA LIGHTING TECHNOLOGY CENTER

*Installation of a downlight*

## RECESSED LUMINAIRES

### Luminaires Recessed in Insulated Ceilings

Luminaires recessed in insulated ceilings can create a thermal bridge through the insulation. This degrades insulation performance and may create condensation on the surface of the luminaire.

Recessed luminaires in insulated ceilings must meet these requirements:

1. **Zero clearance rating:** Must be listed for zero clearance insulation contact by Underwriters Laboratories (UL) or other nationally recognized testing/rating laboratories. This allows insulation to be placed directly in contact with the luminaire.
2. **Airtight construction label:** The recessed luminaire must have an airtight construction certification label. Airtight construction ensures that leakage through the luminaire will not exceed 2.0 CFM when exposed to 75 Pascals pressure difference, tested in accordance with ASTM E283.
3. **Sealed with gasket or caulking:** The recessed luminaire must be sealed with a gasket or caulking between the luminaire housing and ceiling. All air leak paths between conditioned and unconditioned spaces must be sealed to prevent the flow of heated or cooled air out of the living areas into the ceiling cavity.
4. **Readily accessible ballast:** The recessed luminaire must allow readily accessible ballast maintenance and replacement from below the ceiling without having to cut holes through the ceiling.

### “Parts and Labor” Warranty for Failed Ballasts

Typically, when a ballast fails, the homebuilder is responsible for the repair or replacement of the failed unit. To address the concern of premature ballast failure and the associated repair costs, some manufacturers offer a Parts and Labor warranty. The Parts and Labor warranty provides replacement components as well as compensation for costs associated with replacing and installing the luminaire components. Check with the manufacturer of a luminaire to see if this warranty is available.



# SWITCHING CONTROLS

Switching controls, also called lighting controls, are an important component of *Title 24, Part 6*. A combination of low-efficacy luminaires and specific lighting controls can be used as an alternative to high-efficacy luminaires.

These switching devices and controls include occupancy/vacancy sensors and dimmers as well as Energy Management Control Systems that oversee the control functions. All sensors and dimmers must be certified to the Energy Commission for compliance with *Title 24, Part 6*.

## SWITCHING CONTROL REQUIREMENTS

*Title 24, Part 6* specifies the following requirements for switching controls used with permanently installed luminaires:

1. **Separate switching:** All high-efficacy luminaires must be switched separately from low-efficacy luminaires.
2. **Readily accessible manual controls:** All luminaires must be switched with readily accessible manual on/off controls.
3. **Manufacturer's instructions:** All lighting controls must be installed in accordance with the manufacturer's instructions.
4. **Multiple switches:** Lighting circuits controlled by more than one switch, where a certified dimmer or vacancy sensor has been installed, must not have controls that bypass the dimmer or vacancy sensor function.
5. **Lighting associated with exhaust fans:** Must be either: switched separately from the exhaust fan, OR if the lighting is integral to the fan, it must be capable of being manually turned on/off while allowing the fan to continue operation for an extended period of time.
6. **Indicator lights:** Indicator lights integral to lighting control devices must consume no more than 1 W per indicator light.

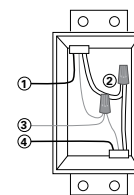

**Single Pole**  
1. Line (Hot)  
2. Neutral  
3. Ground  
4. Load

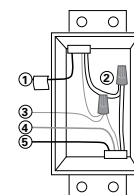

**3-Way**  
1. Line or Load  
2. Neutral  
3. Ground  
4. First Traveler (note color)  
5. Second Traveler (note color)

© LEVITON

*Multiple switches diagram showing wiring of a single switch (top) and a 3-way switch (bottom).*

# VACANCY SENSORS

## VACANCY SENSOR:

A vacancy sensor is an occupant sensor for which the lights must be turned on manually, and the sensor automatically turns lights off within 30 minutes after an area is vacated. Also referred to as a manual-on occupant sensor.

Vacancy sensors are manual-on/automatic-off occupant sensors that automatically turn lights off after a room is unoccupied for a period of time, but must be turned on manually. Vacancy sensors used in a building must be certified to the Energy Commission to be *Title 24, Part 6*-compliant.

## APPLICATIONS

Vacancy sensors may be used as an alternative to high-efficacy luminaires in all applications throughout the house, with the exception of kitchens, which have additional requirements.

## VACANCY SENSOR COMPLIANCE SPECIFICATIONS

Vacancy sensors must meet the following requirements to be certified to the Energy Commission:

1. **Automatic-off:** Must be capable of automatically turning off the lights within 30 minutes after the room has been vacated.
2. **Manual-off:** Must allow the occupant to turn the lights on/off manually.
3. **Visible status signal:** Must have a status signal that indicates if the device is operating properly or has malfunctioned or failed. The visible signal may have an override switch that turns off the signal.
4. **Automatic-on grace period:** Must not turn on the lighting automatically; however, the sensor must have a grace period of 15–30 seconds to turn the lighting on automatically after the sensor has timed out.
5. **No disabling override:** Must not have an override switch to disable the vacancy sensor.
6. **No automatic-on override:** Must not have an override switch that converts the sensor to an automatic-on system.



*WattStopper CS-50 Passive Infrared (PIR) Wall Switch Vacancy Sensor provides automatic shutoff.*

## VACANCY SENSOR MINIMUM LOAD REQUIREMENTS

Vacancy sensors commonly available are wired in two different ways. It is important to select the correct vacancy sensor depending on wiring:

**Load connection (two-wire connection):** Some sensors using a load connection have minimum load requirements to function. If a lamp rated less than the minimum load requirement is installed, the sensor may not work. Therefore, it is critical to select a sensor that will work with the anticipated minimum load. This type of wiring scheme is common in older residential units.

**Neutral connection (three-wire connection):** Vacancy sensors that use the neutral wire in the switch box typically do not have a minimum load requirement and are the preferred choice when a three-wire connection is available.

## OTHER NOTES ON VACANCY SENSORS

1. Install sensors so they can view the entire area that is to be occupied.
2. Avoid using vacancy sensors that use a ground wire for the operating current, as this method presents safety concerns.
3. When using a two-way switch for one lighting fixture, it is recommended to use a ceiling-mounted occupancy sensor rather than a wall-switch sensor. Another option is to use a three-way vacancy sensor at both switch locations.
4. Residential dimmers with low-efficacy lighting are an alternative option to using exclusively high-efficacy lighting in some rooms. Dimmers must be certified to the Energy Commission to be *Title 24, Part 6*-compliant. No other controls may bypass the dimmer control.

### WHAT IS THE DIFFERENCE BETWEEN A VACANCY SENSOR AND AN OCCUPANT SENSOR?

A vacancy sensor is an occupant sensor for which the lights must be manually turned on, but the sensor turns them off after the space has been vacated. An occupant sensor controls interior lights based on occupancy.

## OTHER ROOMS

Other rooms include any room or area that is not a kitchen, bathroom, garage, closet larger than 70 ft<sup>2</sup>, laundry room, or utility room (e.g., hallway, dining room, family room, home office, bedroom, attic space, wine cellar).



Leviton Decora Dimmable CFL and Incandescent Sureslide Dimmer available in single pole and 3-way



Lutron Diva dimmer switch with large paddle switch and small slider to allow light to be turned on and off at desired light level



WattStopper RD-250 PIR Dimming Multi-way Convertible Occupancy Sensor

# DIMMERS

## APPLICATIONS

Dimmers may only be used as an alternative to high-efficacy luminaires or vacancy sensors in bedrooms, hallways, dining rooms, family rooms, home offices, and attics. In *Title 24, Part 6*, these are classified as other rooms.

## DIMMER COMPLIANCE SPECIFICATIONS

Dimmers must meet the following requirements to be certified to the Energy Commission:

1. **65% power reduction:** Must reduce power consumption by at least 65% at its lowest light level.
2. **Electrical outputs to lamps:** Must provide electrical outputs to lamps if controlling an incandescent or fluorescent lamp to reduce visual flicker through the dimming range.
3. **UL-compliant:** Must be listed as compliant with the UL Standards by a rating lab recognized by the International Code Council.
4. **Multi-way circuits with non-dimming switches:** **Wall box dimmers** designed for a system with three or more circuits with non-dimmable switches must not allow the switches to override the dimmer level. The dimmer and all switches in the circuit must be able to turn the lighting on/off. When turning on, the dimmer and all switches must return the lighting to the level set by the dimmer when last turned off. The dimmer may be controlled by an emergency override system.
5. **Off position:** If the device is a **stepped dimmer**, it must include an off position to turn the lights completely off.

## MULTI-WAY DIMMING CIRCUITS

Multi-way dimming controls are three-way, four-way, and other multiple location dimming circuit combinations where a single multi-way dimmer may be combined with other multi-way dimmers or multi-way toggle switches. Regular toggle switches may be combined with dimmers provided that the toggle switches do not override the dimmer control.

## DIMMER USAGE RECOMMENDATIONS

**Small rooms:** Use a multi-way toggle switch with a multi-way dimmer.

**Large rooms, long hallways, stairways:** Use multi-way dimmers throughout the space so that lights can be dimmed from all locations.

**Lighting load:** Failure to correctly match the dimmer with the electrical lighting load may result in early equipment failure.

**Fluorescent lamps:** Dimmers may be used with fluorescent lamps. However, many fluorescent lamps cannot be properly dimmed with the typical wallbox devices used with incandescent lamps. A special control and dimming ballast must be used. CFLs often cannot be dimmed at all; check the packaging to see if they are dimmable.

## TYPES OF INCANDESCENT DIMMERS

**Line voltage (120 volt):** Line voltage incandescent lamps are easily dimmed over their full range of output with voltage control or phase control (electronic) dimmers. Tungsten-halogen lamps can be dimmed with conventional incandescent dimmers.

**Low-voltage with magnetic transformers:** Magnetic transformers step down 120VAC line voltage to 12VAC or 24VAC. Magnetic transformers use copper wound around a steel core, storing energy in the form of a magnetic field. Magnetic transformers are relatively large and often heavy.

**Low-voltage with electronic transformers:** Electronic transformers also step down 120VAC line voltage to 12VAC or 24VAC. This is done with electronic circuitry, which stores an electric charge. Electronic transformers are compact and lightweight.



WattStopper WD dimmers work with fluorescent fixtures using ballasts with line voltage phase control input or Advance® Mark X™ electronic dimmable ballasts.

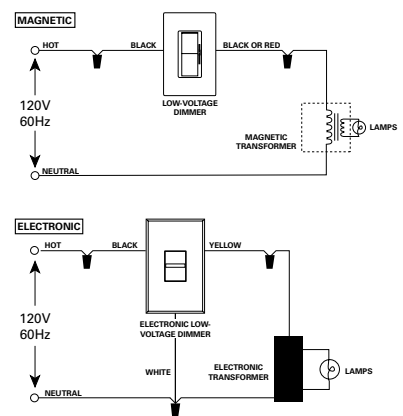

© LUTRON

Typical wiring for dimmer with a magnetic transformer (top) and an electronic transformer (bottom)

## OTHER CONTROL DEVICES



WattStopper LMIO-301 photocell input module for a Digital Lighting Management (DLM) system. May be used to control interior and exterior lighting.

### ENERGY MANAGEMENT CONTROL SYSTEMS

An **Energy Management Control System (EMCS)** is a computerized control system designed to regulate the energy consumption of a building by controlling the operation of energy-consuming systems, such as lighting.

### PHOTOCONTROL

A **photocontrol** is a device that switches or controls lighting loads based on ambient light levels.

### ASTRONOMICAL TIME CLOCK

Automatic time-switch control devices such as an **astronomical time clock** are capable of automatically switching or controlling lighting loads based on time schedules. According to the *2008 Title 24 Building Energy Efficiency Standards*, outdoor astronomical time-switch controls must:

1. Contain at least two separately programmable steps per function area.
2. Have the ability to independently offset the on/off times for each channel by 0–99 minutes before or after sunrise or sunset.
3. Have sunrise and sunset prediction accuracy within +/- 15 minutes, and timekeeping accuracy within five minutes per year.
4. Display date, time, sunrise, and sunset.
5. Have an automatic adjustment for daylight saving time.
6. Include the option to program different schedules for weekdays and weekends.
7. Have program backups to prevent loss of schedules for at least seven days, and time and date for at least 72 hours if power is interrupted.
8. Store astronomical time parameters (used to develop longitude, latitude, time zone) for at least seven days if power is interrupted.



Leviton Vizia+ 24-hour Timer with astronomical clock, timer settings, and green LED locator

# PURCHASE & SELECTION

## FIXTURE LABELS FOR COMPLIANCE AND QUALITY

The following labels may be helpful in specifying high-quality and compliant fixtures. However, not every compliant product is identified by a label. It is important to ensure that controls used with low-efficacy lighting and high-efficacy LED luminaires are certified to the Energy Commission; check the Appliance Efficiency Database for compliance. All other luminaires used as high-efficacy lighting must meet the efficacy requirements provided in Table 1.

### ENERGY STAR Label

The ENERGY STAR label guarantees a minimum standard of quality as well as energy performance. Many ENERGY STAR brand products will meet *Title 24, Part 6* code; however, not all products are guaranteed to be *Title 24, Part 6*-compliant. ENERGY STAR is a national brand, and *Title 24* is a California regulation.



ENERGY STAR Label

### Airtight Fixture Label

*Title 24, Part 6* requires that recessed fixtures installed in an insulated ceiling be certified airtight in accordance with ASTM E283. If the fixture label does not specify ASTM E283 certification, additional documentation will be required to indicate the fixture has been tested and certified in accordance with ASTM E283. For complete airtight compliance, the installation also must be airtight with respect to the seal between the ceiling and fixture. This can be accomplished with either sealed gasket(s) or caulking. For more information, see the *Residential Compliance Manual*, Chapter 6.10.



AIR-TIGHT Label

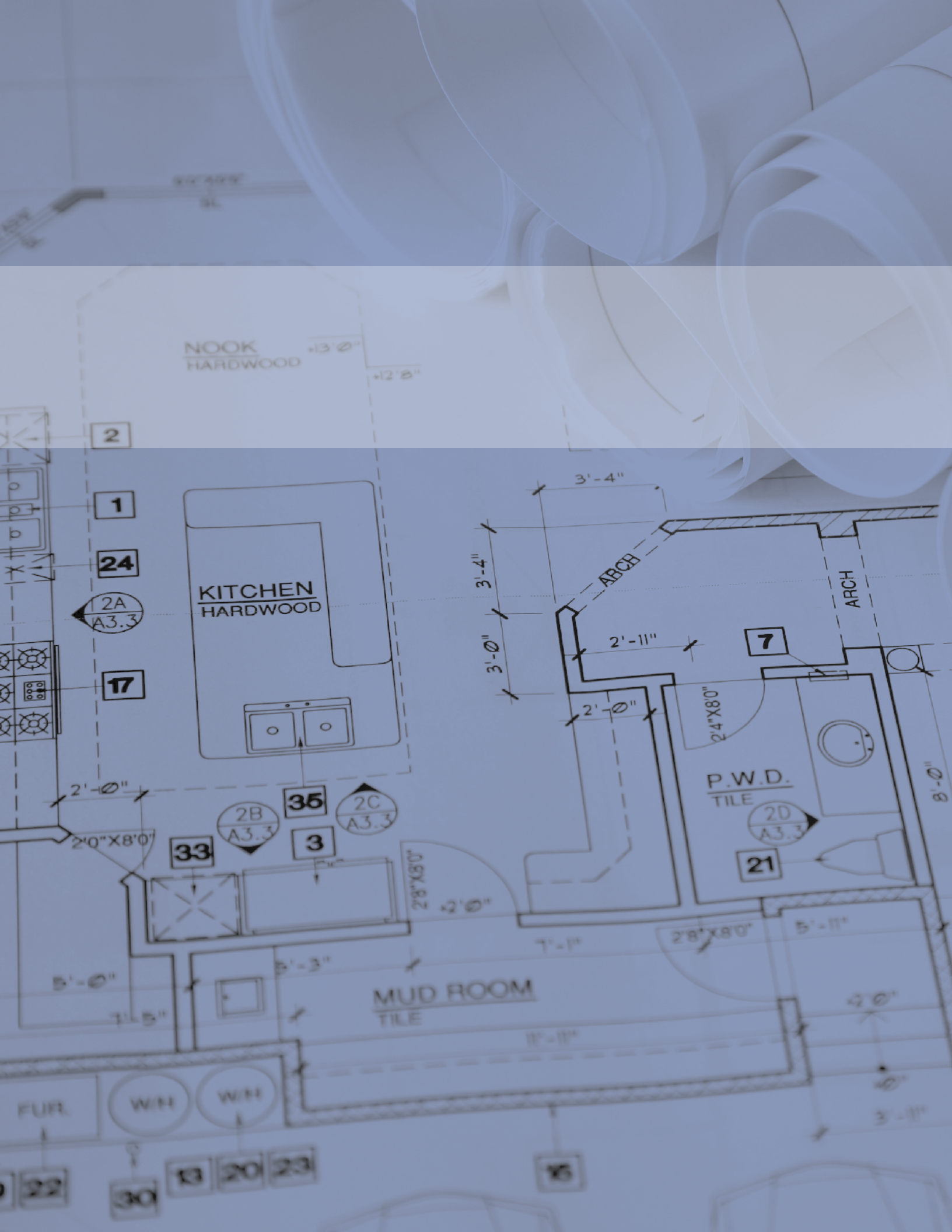

NOOK  
HARDWOOD

+13'-0"

+12'-8"

2

1

24

17

KITCHEN  
HARDWOOD

2A  
A3.3



2'-0"

2'-0" X 8'-0"

33

2B  
A3.3

35

2C  
A3.3

3



7

P.W.D.  
TILE

21

20  
A3.3

5'-0"

7'-5"

5'-3"

MUD ROOM  
TILE

7'-1"

2'-8" X 8'-0"

5'-11"

FUR

WH

WH

22

30

13

20

23

16

2'-0"

6"

3'-11"

8'-0"



# LIGHTING DESIGN GUIDE

<i>Title 24, Part 6 Changes</i>	24
<b>Introduction to Lighting Design</b>	26
<b>Kitchens</b>	27
<b>Bathrooms, Garages, Laundry Rooms, &amp; Utility Rooms</b>	30
<b>Other Rooms</b>	33
<b>Outdoor Lighting</b>	37
<b>Multi-family Common Areas</b>	41
<b>Parking Lots &amp; Garages</b>	42

# TITLE 24, PART 6 CHANGES

	KITCHEN	BATHROOMS, GARAGES, CLOSETS, LAUNDRY ROOMS, & UTILITY ROOMS	OTHER INTERIOR ROOMS						
2008	<p><b>At least 50%</b> of lighting watts must be from high-efficacy luminaires.</p> <hr/> <p><b>Low-Efficacy Trade-off Option</b></p> <p>Under certain circumstances, if installed low-efficacy lighting wattage in a kitchen is less than the installed high-efficacy wattage in the kitchen, the following additional low-efficacy wattage may be installed. See page 27.</p> <table border="1"> <thead> <tr> <th>Size of Unit</th> <th>Additional low-efficacy wattage in kitchen</th> </tr> </thead> <tbody> <tr> <td>≤ 2,500 ft<sup>2</sup></td> <td>Up to 50 additional watts</td> </tr> <tr> <td>&gt; 2,500 ft<sup>2</sup></td> <td>Up to 100 additional watts</td> </tr> </tbody> </table>	Size of Unit	Additional low-efficacy wattage in kitchen	≤ 2,500 ft <sup>2</sup>	Up to 50 additional watts	> 2,500 ft <sup>2</sup>	Up to 100 additional watts	<p><b>All lighting</b> must be high efficacy.</p> <p><b>OR</b></p> <p>Low-efficacy lighting controlled by a <b>vacancy sensor</b>.</p>	<p><b>All lighting</b> must be high efficacy.</p> <p><b>OR</b></p> <p>Low-efficacy lighting controlled by a <b>vacancy sensor</b>.</p> <p><b>OR</b></p> <p>Low-efficacy lighting controlled by a <b>dimmer switch</b>.</p>
Size of Unit	Additional low-efficacy wattage in kitchen								
≤ 2,500 ft <sup>2</sup>	Up to 50 additional watts								
> 2,500 ft <sup>2</sup>	Up to 100 additional watts								
2005	<p>High efficacy.</p> <p>OR</p> <p>Up to 50% of the total wattage can be low efficacy.</p> <p>All high-efficacy and low-efficacy lighting must be controlled separately.</p>	<p>High efficacy.</p> <p>OR</p> <p>Manual-on occupancy sensor.</p>	<p>High efficacy.</p> <p>OR</p> <p>Manual-on occupancy sensor.</p> <p>OR</p> <p>Dimmer.</p>						
2001	<p>High efficacy.</p> <p>AND</p> <p>Controlled by the primary switch at the kitchen entrance.</p> <p>Additional luminaires used for decorative effects need not meet this requirement.</p>	<p>Each bathroom containing a shower or bathtub must have at least one fluorescent luminaire.</p> <p>OR</p> <p>Fluorescent lighting may be installed in a utility room, laundry room, or garage instead of a bathroom.</p> <p>AND</p> <p>All other lighting must be fluorescent or equipped with a motion sensor.</p> <p>If using the alternative option, each additional bathroom must have at least one fluorescent luminaire.</p>	<p>No requirements.</p>						

OUTDOOR LIGHTING	COMMON AREAS OF MULTI-FAMILY BUILDINGS	PARKING LOTS AND GARAGES
<p><b>All lighting</b> must be high efficacy.</p> <p style="text-align: center;"><b>OR</b></p> <p>Low-efficacy lighting controlled by a <b>manual on/off switch AND a motion sensor AND one of the following three methods</b> to automatically turn lights off during daytime, without an override or bypass switch:</p> <ol style="list-style-type: none"> <li>1. <b>Integral Photocontrol</b></li> <li>2. <b>Astronomical Time Clock</b></li> <li>3. <b>Energy Management Control System</b></li> </ol>	<p><b>All lighting</b> must be high efficacy.</p> <p style="text-align: center;"><b>OR</b></p> <p>Low-efficacy lighting controlled by <b>occupancy sensors</b>.</p>	<p><b>Parking lots and carports</b> for seven or fewer cars must meet <b>Title 24, Part 6 Outdoor Residential Lighting Standards</b>.</p> <hr/> <p><b>Parking garages</b>, either attached or detached from the dwelling unit, for seven or fewer cars per site must meet <b>Title 24, Part 6 Indoor Residential Lighting Standards</b>.</p> <hr/> <p><b>Parking lots and garages</b> for eight or more vehicles per site must meet <b>Title 24, Part 6 Outdoor Nonresidential Lighting Standards</b>.</p>
<p>High efficacy.</p> <p>OR</p> <p>Controlled by motion sensor and integral photocontrol.</p>	<p>High efficacy.</p> <p>OR</p> <p>Occupancy sensor.</p>	<p>Must meet <i>Title 24, Part 6</i> Nonresidential Lighting Standards.</p>
<p>No requirements.</p>	<p>No requirements.</p>	<p>No requirements.</p>

# INTRODUCTION TO LIGHTING DESIGN

In the Lighting Design section, each space regulated by the *2008 Title 24 Building Energy Efficiency Standards* is featured along with corresponding lighting standards, definitions of spaces, lighting plans, lighting legends, and design tips.

## APPLIANCE EFFICIENCY DATABASE

[www.appliances.energy.ca.gov](http://www.appliances.energy.ca.gov)

### LIGHTING PLANS

The luminaires, lamps, and controls used in these lighting plans qualify as high efficacy, and many of the technologies can be found in the Energy Commission's Appliance Efficiency Database. Most of the plans included in this section use high-efficacy lighting that not only meets the code, but exceeds code requirements.

### LIGHTING LEGENDS

Each plan is accompanied by a lighting legend, which includes descriptions of luminaires and lamps used in each plan, lamp wattage, and lamp efficacy. All high-efficacy lighting symbols are marked either by an "L" for LED lighting or an "FL" for fluorescent lighting. Refer to Tables 1 and 2 on page 10 for the requirements for a luminaire or lamp to be considered high efficacy.

### LIGHTING TIPS

Each plan includes extra considerations to take into account when designing lighting for each space. Also included are recommendations for added energy savings, beyond the *2008 Title 24 Building Energy Efficiency Standards*.

---

**Note: Wattage only matters in kitchens.** Ballast wattage is included in efficacy calculations for kitchens, but not for other rooms.

# KITCHENS

## LIGHTING STANDARDS

**At least 50%** of lighting watts must be from high-efficacy luminaires.

### Low-Efficacy Trade-off Option

Additional low-efficacy wattage may be installed under the following conditions:

1. All permanently installed luminaires in garages, closets greater than 70ft<sup>2</sup>, laundry rooms, and utility rooms must be high efficacy **AND** controlled by a vacancy sensor.
2. All low-efficacy lighting in the kitchen must be controlled by a manual-on/automatic-off occupancy sensor, a dimmer, an EMCS, or a multi-scene programmable control system.

Size of Unit	Additional low-efficacy wattage in kitchen
≤ 2,500 ft <sup>2</sup>	Up to 50 additional watts
> 2,500 ft <sup>2</sup>	Up to 100 additional watts

## KITCHEN LIGHTING TIPS

- When calculating the wattage ratio of high-efficacy luminaires to low-efficacy luminaires for a kitchen, determine the rated input watts of the lighting system, including any additional wattage used by the ballasts.
- LED luminaires that have not been certified to the Energy Commission as high efficacy shall be classified as low-efficacy lighting. The installed LED system wattage must include transformers, power supplies, and any other power-consuming components.

## KITCHEN:

A room or area used for food storage and preparation, and washing dishes.

- Includes associated countertops and cabinets, refrigerator, stove, oven, and floor areas.
- Includes dining and nook areas if they use the same switches as the kitchen lighting.
- Does not include lighting internal to cabinets that illuminate only the inside of the cabinet.



© SAGE ARCHITECTURE INC.  
© DAVE ADAMS PHOTOGRAPHY

## CALCULATION EXAMPLE

A contractor plans to install six 26W CFL downlights and four linear fluorescent undercabinet luminaires with electronic ballasts that are rated by the ballast manufacturer as 25W. How many watts of low-efficacy lighting can be installed?

$$26 \times 6 = 156 \text{ W}$$

$$25 \times 4 = 100 \text{ W}$$

$$\text{Total} = 256 \text{ W}$$

The maximum watts of low-efficacy lighting that can be installed is 256W.

A 1,700ft<sup>2</sup> house meeting the conditions for the low-efficacy trade-off option would be allowed an additional 50W of low-efficacy lighting, for a total of 306W of low-efficacy lighting.

## STANDARD KITCHEN LIGHTING PLAN

148 square feet

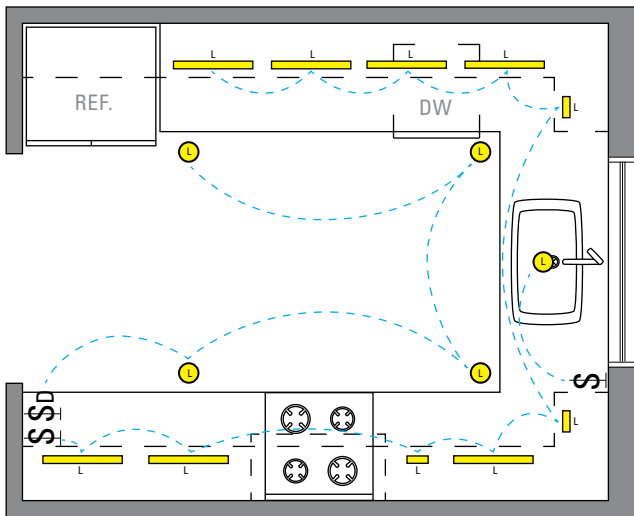

### KITCHEN LIGHTING TIPS

1. Light the countertops more than the walkway.
2. Provide lighting where it will support specific tasks and overall function of the space.
3. Provide a recessed can above the sink on a separate switch.
4. Supplement recessed can lighting with high-efficacy undercabinet light fixtures on separate switches.
5. The Illuminating Engineering Society recommends kitchen designs to achieve at least 30 footcandles on most kitchen counters and work surfaces.

STANDARD KITCHEN LIGHTING FIXTURE LEGEND							
Symbol	Description	Lamp Type	Qty.	Watts	Total Watts	Efficacy (lm/W)	
	Recessed downlight	GU-24 base LED	5	12	<b>60</b>	<b>56</b>	
	1-light undercabinet fixture	LED *	3	4	<b>12</b>	<b>32</b>	
	3-light undercabinet fixture	LED *	7	9	<b>63</b>	<b>40</b>	
	Switch						
	Dimmer switch						
<b>LED watts: 135</b>				<b>At least 50% high-efficacy watts? Yes</b>			

\* **Note:** To be *Title 24, Part 6*-compliant, the LED luminaires (or at least half the wattage used by the LED luminaires) would need to be certified to the Energy Commission.

# MODEL KITCHEN LIGHTING PLAN

289 square feet

## KITCHEN LIGHTING TIPS

1. Use aesthetically pleasing light fixtures to complement the design of the kitchen.
2. Minimize the number of fixtures extending below the ceiling to reduce visual clutter.
3. Provide separate switches for versatility in the lighting environment.
4. Provide a three-way switch for the recessed cans with switches located at both entry points of the room.
5. Pantries less than 70 ft<sup>2</sup> are not regulated by *Title 24, Part 6*.
6. Locate recessed cans at the edge of the counter to reduce shadows that may be caused by the occupant.
7. Supplement recessed cans with high-efficacy undercabinet light fixtures on separate switches.

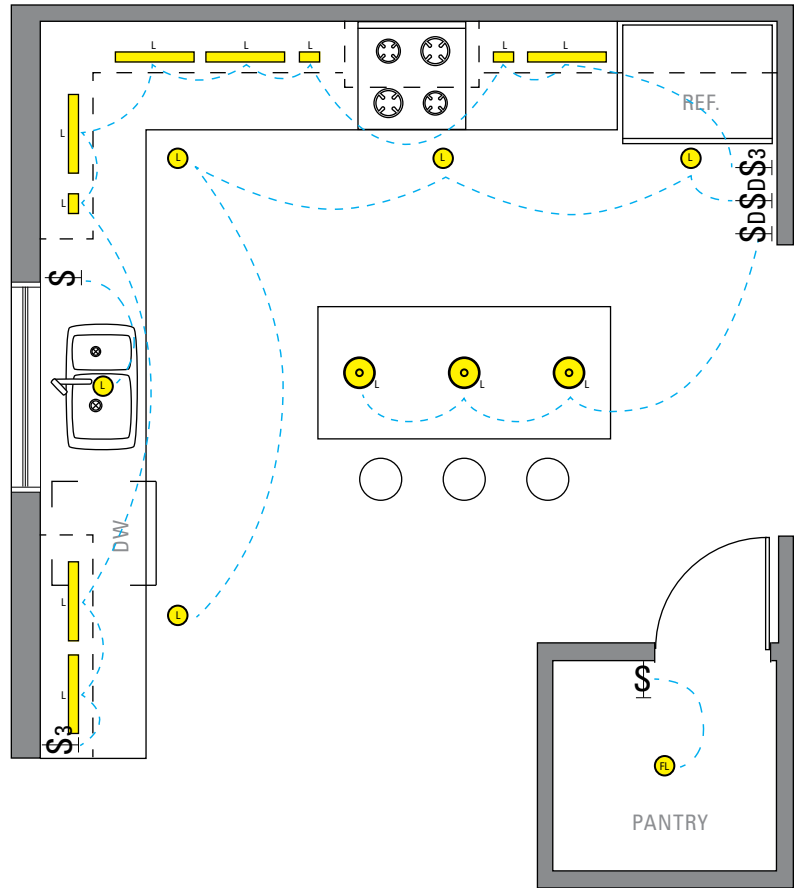

KITCHENS

## MODEL KITCHEN LIGHTING FIXTURE LEGEND

Symbol	Description	Lamp Type	Qty.	Watts	Total Watts	Efficacy (lm/W)
	Recessed downlight	GU-24 base LED	5	12	60	56
	Flush mount faux recessed	GU-24 base CFL	1	26	26	69
	1-light undercabinet fixture	LED	3	4	12	32
	3-light undercabinet fixture	LED	6	9	54	40
	Pendant	LED	3	8	24	15
	Switch					
	Dimmer switch					
	3-way switch					

**LED watts: 150**  
**Fluorescent watts: 26**

**Total wattage: 176**  
**At least 50% high-efficacy? Yes**

# BATHROOMS, GARAGES, CLOSETS, LAUNDRY ROOMS, & UTILITY ROOMS



**LIGHTING STANDARDS**

**All lighting** must be high efficacy.

**OR** low-efficacy lighting controlled by a **vacancy sensor**.

**BATHROOM LIGHTING TIPS**

- If a sink used for personal hygiene is in a room other than a bathroom and includes lighting switched separately from the room area lighting, only the sink area luminaire(s) must comply with *Title 24, Part 6* Bathroom Lighting Standards.
- More than one luminaire may be attached to the same vacancy sensor.
- Regarding bathroom vacancy sensors, at least one high-efficacy luminaire not controlled by a sensor is recommended to ensure that one luminaire remains on when little movement is detected (e.g., someone taking a bath).

**GARAGE LIGHTING TIPS**

- Garage work areas—normally farthest from the door to the house—can be switched separately from the rest of the space with high-efficacy luminaires for task lighting.

**CLOSET LIGHTING TIPS**

- Closets less than 70ft<sup>2</sup> are exempt from *Title 24, Part 6* requirements.
- Hallways with storage shelves are considered hallways and must comply with *Title 24, Part 6* Other Rooms Residential Lighting Standards.

**BATHROOM**  
A room or area containing a sink used for personal hygiene, toilet, shower, or tub.

**GARAGE**  
A non-habitable building or portion of a building, attached to or detached from a residential dwelling unit, in which motor vehicles are parked.

**CLOSET**  
A non-habitable room used to store linens, household supplies, clothing, non-perishable food, or similar uses, which is not a hallway or passageway. *Title 24, Part 6* only applies to closets larger than 70ft<sup>2</sup>.

**LAUNDRY ROOM**  
A non-habitable room or space that contains plumbing and electrical connections for a washing machine and/or clothes dryer.

**UTILITY ROOM**  
A non-habitable room or building that contains only HVAC, plumbing, or electrical controls or equipment, and which is not a bathroom, closet, garage, or laundry room.



**HIGH-EFFICACY AND VACANCY SENSOR OPTION FOR ADDITIONAL LOW-EFFICACY KITCHEN LIGHTING**

Additional low-efficiency lighting may be used in the kitchen if both high-efficiency lighting and vacancy sensors are included in the garage, closets larger than 70 ft<sup>2</sup>, laundry room, and utility rooms. Although not required, high-efficiency luminaires may be used with vacancy sensors to achieve the lowest possible energy use.

**STANDARD BATHROOM LIGHTING PLAN**

45 square feet

**BATHROOM LIGHTING TIPS**

1. Use a decorative CFL bath bar fixture over the mirror.
2. Provide separate switches for versatility in the lighting environment.
3. Vacancy sensors and dimmers will allow for maximum energy saving potential.

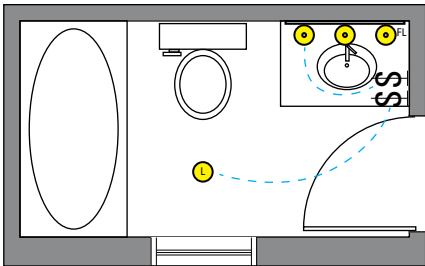

STANDARD BATHROOM LIGHTING FIXTURE LEGEND						
Symbol	Description	Lamp Type	Qty.	Watts	Total Watts	Efficacy
L	Recessed downlight	GU-24 base LED	1	12	12	56
FL	3-light bath bar	Pin-base or GU-24 base CFLs with electronic ballasts	3	13	39	69
\$	Switch					

# MASTER BATHROOM LIGHTING PLAN

228 square feet

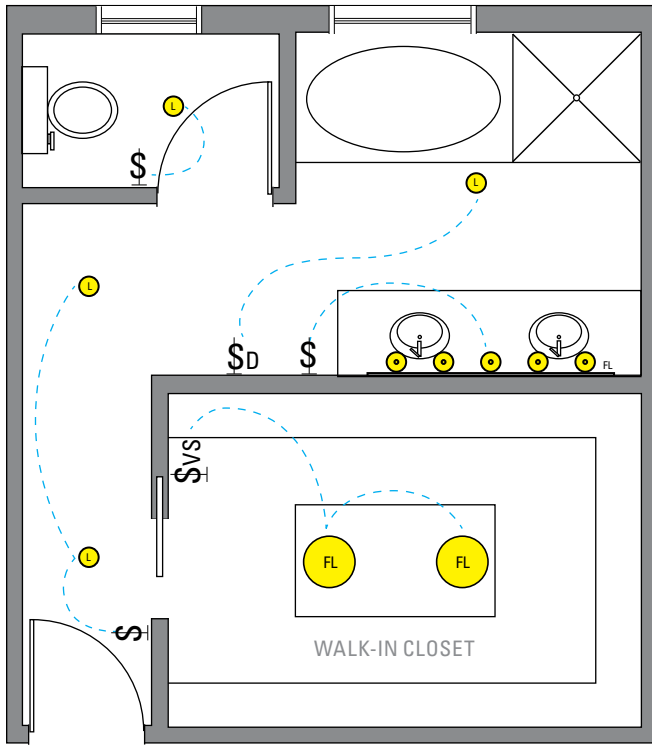

## BATHROOM LIGHTING TIPS

1. Use fluorescent surface-mounted fixtures in closets to provide an even spread of light on shelving and throughout space.
2. Using multiple fixture types on separate switches provides a specific source of light for each function in the space and versatility in the lighting environment.
3. Use a decorative CFL bath bar fixture over the mirror.

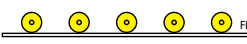
MASTER BATHROOM LIGHTING FIXTURE LEGEND						
Symbol	Description	Lamp Type	Qty.	Watts	Total Watts	Efficacy (lm/W)
L	Recessed downlight	GU-24 base LED	4	12	<b>48</b>	<b>56</b>
	5-light bath bar	Pin-base or GU-24 base CFLs with electronic ballasts	5	13	<b>65</b>	<b>69</b>
FL	Surface-mounted fixture	Pin-base or GU-24 base CFLs with electronic ballasts	2	13	<b>26</b>	<b>69</b>
\$	Switch					
\$D	Dimmer switch					
\$VS	Vacancy sensor switch					



# OTHER ROOMS

## LIGHTING STANDARDS

- All lighting** must be high efficacy.
- OR** low-efficacy lighting controlled by a **vacancy sensor**.
- OR** low-efficacy lighting controlled by a **dimmer switch**.

## OTHER ROOMS

Other rooms include any room or area that is not a kitchen, bathroom, garage, closet larger than 70 ft<sup>2</sup>, laundry room, or utility room (e.g., hallway, dining room, family room, home office, bedroom, attic space, wine cellar).

## OTHER ROOMS LIGHTING TIPS

- Use several luminaires throughout a room to allow variations of light and reduced shadows, minimizing the need for residents to add portable lighting to the room.
- Provide separate switches for each luminaire to allow residents control over the appearance of their rooms while also reducing energy use.
- Concealed lighting such as linear fluorescent or LED cove lighting can increase the marketability of a residence.
- Lights attached to a vacancy sensor may turn off prematurely when people are still in the room but not enough motion is seen by the sensor. An option to address this issue is to install a high-efficacy luminaire, which can be controlled by a manual on/off switch.
- Detached residential storage buildings less than 1,000 ft<sup>2</sup> are exempt from *Title 24, Part 6*.



# LIVING ROOM & DINING ROOM

289 square feet

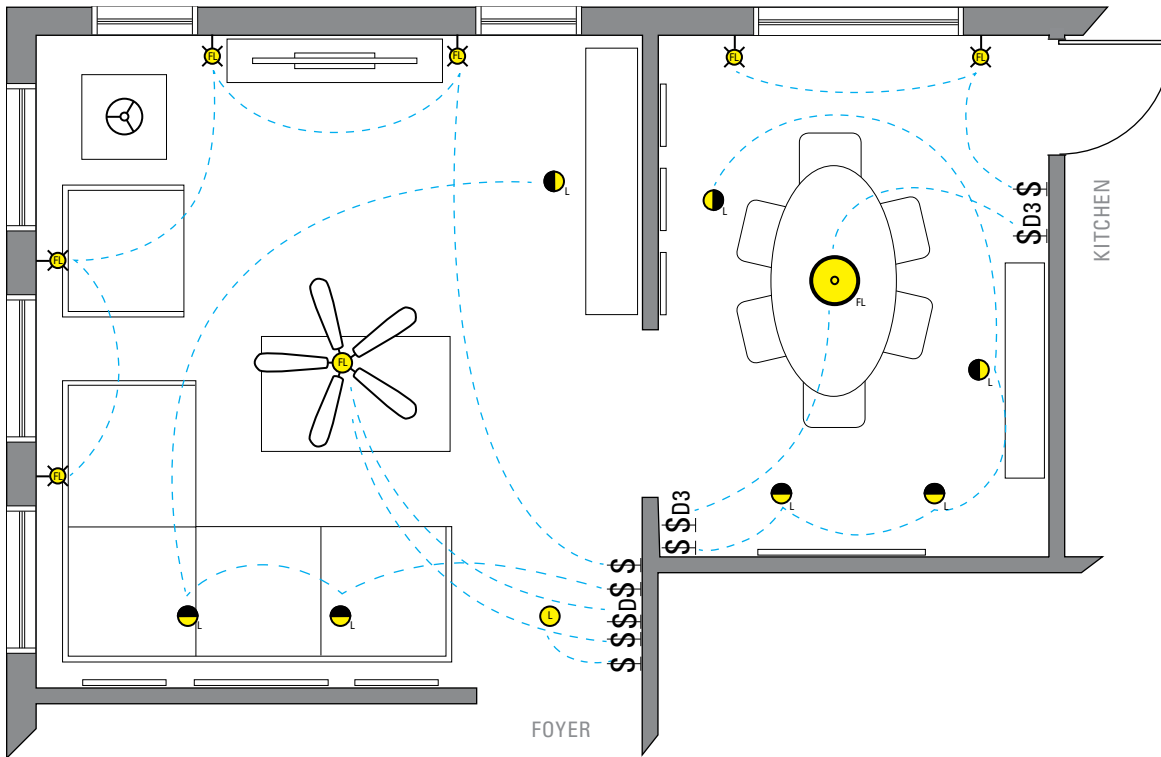

OTHER ROOMS

LIVING ROOM AND DINING ROOM LIGHTING FIXTURE LEGEND							
Symbol	Description	Lamp Type	Qty.	Watts	Total Watts	Efficacy (lm/W)	
	Wall sconce	Pin-base or GU-24 base CFLs with electronic ballast	6	13	<b>78</b>	<b>69</b>	
	Ceiling fan with lamp and fan motor on separate switches	Pin-base or GU-24 base CFLs with dimming electronic ballast	1	26	<b>26</b>	<b>60</b>	
	Pendant on dimmer switch	Pin-base or GU-24 base CFLs with dimming electronic ballast	1	13	<b>13</b>	<b>69</b>	
	Recessed wallwasher	GU-24 base LED	7	12	<b>84</b>	<b>56</b>	
	Recessed downlight	GU-24 base LED	1	12	<b>12</b>	<b>56</b>	
	Switch						
	Dimmer switch						
	3-way dimmer switch						

## LIVING ROOM & DINING ROOM LIGHTING TIPS

1. Use a fluorescent pendant with a three-way dimmer switch in the dining room to provide versatility in the lighting environment and a control at both entry points to the room.
2. Use sconces to provide low light levels for activities that do not require full lighting.
3. Use multiple fixture levels and types to provide versatility in ambience for living rooms and dining rooms.
4. Use wallwashers to eliminate harsh shadows or cones of light and to provide overall illumination throughout the space.
5. When using ceiling fans with fluorescent light kits, provide one on/off switch for the fan and one on/off switch for the light. A dimmer switch is shown in this example to allow for versatility in the lighting environment.

## HALLWAY LIGHTING PLAN

67 square feet

### TIPS FOR HALLWAY LIGHTING:

1. Use high-efficacy fixtures with three-way switches.
2. Locate switches in a place that is easily accessed by multiple rooms.
3. Multi-way sensors and dimmers provide additional control options in hallways to maximize energy savings.

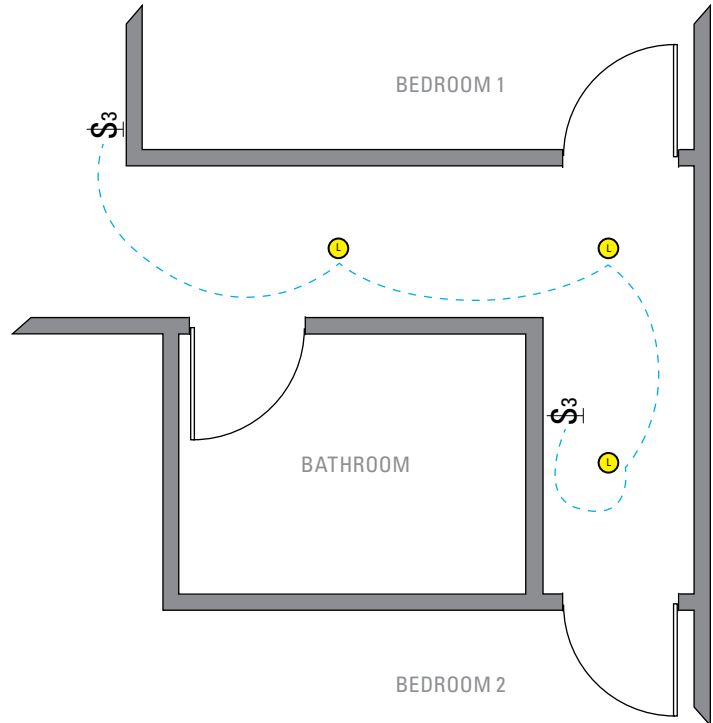

OTHER ROOMS

### HALLWAY LIGHTING FIXTURE LEGEND

Symbol	Description	Lamp Type	Qty.	Watts	Total Watts	Efficacy (lm/W)
L	Recessed downlight	GU-24 base LED	3	12	36	56
\$3	3-way switch					

## BEDROOM LIGHTING PLAN

144 square feet

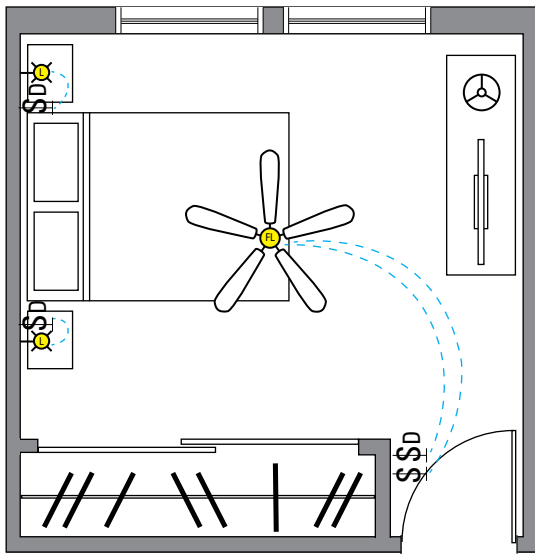

### BEDROOM LIGHTING TIPS

1. Use high-efficacy fluorescent fixtures with one or more on/off switches.
2. When using ceiling fans with fluorescent light kits, provide one on/off switch for the fan and one on/off switch for the light. A dimmer switch is shown in this example for versatility in the lighting environment.
3. Use separate switches for the LED sconces to accommodate multiple occupants.

### BEDROOM LIGHTING FIXTURE LEGEND

Symbol	Description	Lamp Type	Qty.	Watts	Total Watts	Efficacy (lm/W)
	Wall sconce	Dimmable LED lamp	2	8	<b>16</b>	<b>54</b>
	Ceiling fan with lamp and fan motor on separate switches	Pin-base or GU-24 base CFLs with dimming electronic ballast	1	26	<b>26</b>	<b>60</b>
	Dimmer switch					



# OUTDOOR LIGHTING

## LIGHTING STANDARDS

**All lighting** must be high efficacy.

**OR** low-efficacy lighting controlled by a **manual on/off switch AND a motion sensor AND one** of the following three devices to automatically turn lights off during daytime:

1. **Photocontrol** without an override or bypass switch.
2. **Astronomical Time Clock** without an override or bypass switch.
3. **Energy Management Control System (EMCS)** without an override or bypass switch that would allow the luminaire to always be on.

## TEMPORARY OVERRIDE OF MOTION SENSOR OPTION

For occasions that require residential outdoor lighting to be on for more than 30 minutes after the sensor has stopped sensing activities, low-efficacy outdoor luminaires controlled by a motion sensor may have a temporary override switch to bypass the motion-sensing function. The motion sensor must be automatically reactivated within six hours.

## ADDRESS SIGNS

Internally illuminated address signs must:

1. Comply with the *Title 24, Part 6* Sign Standards, **OR**
2. Not contain a screw-base socket, and consume no more than 5W.

## OUTDOOR LIGHTING

Permanently installed luminaires attached to a residential building that provide lighting for private patios, entrances, balconies, and porches.



OUTDOOR

## OUTDOOR LIGHTING TIPS

- CFLs used in spaces with very hot or very cold temperatures should be specified accordingly. Amalgam CFLs perform better at both very high and very low temperatures than non-amalgam versions, so are appropriate for outdoor lighting, although they can take a few minutes to reach full output. An incandescent source may be used as a low-efficacy alternative for these temperatures, or an LED source as a high-efficacy alternative to CFLs in cold temperatures.
- Control devices must have an indicator that visibly or audibly informs the user that the controls are operating correctly, or have failed or malfunctioned.
- Decorative landscape lighting not permanently attached to residential buildings is not regulated by *Title 24, Part 6*.
- Although not required by *Title 24, Part 6*, a time clock or photocontrol on outdoor lighting not permanently attached to a residential building, such as landscape lighting, can help save energy by automatically turning lights off during the day.
- Permanently installed luminaires in or around swimming pools, spas, hot tubs, or fountains subject to Article 680 of the California Electrical Code do not need to be high efficacy.



© SAGE ARCHITECTURE INC.  
© DAVE ADAMS PHOTOGRAPHY





## FRONT PORCH LIGHTING PLAN

### FRONT PORCH LIGHTING TIPS

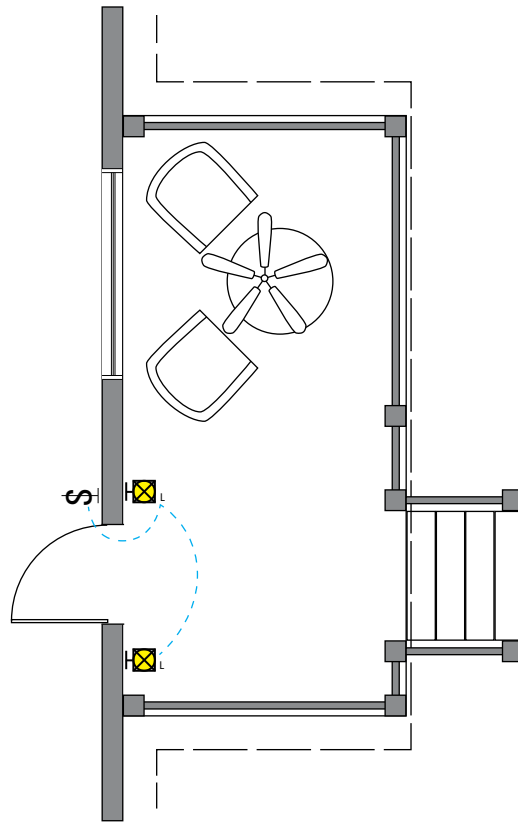
1. LEDs are ideal for colder outdoor environments, as CFLs often are not compatible with lower temperatures.
2. Including a motion sensor will provide light to occupants upon entering the space when no immediate access to a switch is available.
3. For outdoor areas near bedroom windows, high-efficacy luminaires are preferred over low-efficacy luminaires with motion sensors that may be triggered at night.
4. Using an Astronomical Time Switch to control outdoor lights will ensure that lights are on when desired for safety and security reasons, but are not left on all night.



### FRONT PORCH LIGHTING FIXTURE LEGEND

Symbol	Description	Lamp Type	Qty.	Watts	Total Watts	Efficacy (lm/W)
	Exterior wall sconce	LED	2	5	10	35
	Switch					

## OUTDOOR SPACE LIGHTING PLAN

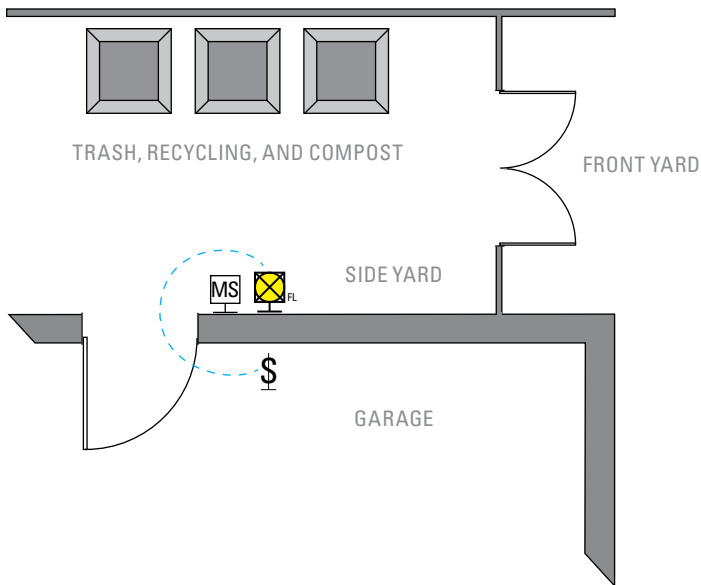

### OUTDOOR LIGHTING TIPS

1. Provide adequate lighting to support the function of the space and specific tasks performed within it.
2. Including a motion sensor will provide light to occupants where there is not immediate access to a switch in a transitional space.
3. Motion sensor coverage should not be too large, or lights will be triggered by street traffic or a neighbor's motion. Most sensors have a sensitivity control to adjust the degree of motion and light that triggers them.
4. In addition to the motion sensor and one of the three other lighting control devices, the owner also must be provided with a manual on/off switch for low-efficiency luminaires.

### OUTDOOR SPACE LIGHTING FIXTURE LEGEND

Symbol	Description	Lamp Type	Qty.	Watts	Total Watts	Efficacy (lm/W)
	Exterior sconce	Pin-base or GU-24 base CFL with electronic ballast	1	12	<b>12</b>	<b>56</b>
	Motion sensor with photocontrol					
	Switch					



# MULTI-FAMILY COMMON AREAS

## LIGHTING STANDARDS

**All lighting** must be high efficacy.

**OR** low-efficacy lighting controlled by **occupant sensors**.

## MULTI-FAMILY COMMON AREA LIGHTING TIPS

- For common areas accommodating elderly or visually impaired residents, the quality of light must be particularly high to allow them to find their way safely through spaces that contain unexpected obstacles.
- Staircases and stairwells are best lit with directional light from above to maximize contrast between treads and risers. CFL luminaires with reflectors are a high-efficacy way to provide this lighting.
- Fixture integrated sensors can maximize energy savings, ensuring lights are off when the space is vacant and offering high/low options when the space is occupied.

## LOW-RISE RESIDENTIAL BUILDING

Low-rise buildings consist of three or fewer habitable stories. Residential buildings with more than three habitable stories are considered high-rise buildings and must follow the *Title 24, Part 6* High-Rise Residential Lighting Standards.

## MULTI-FAMILY BUILDING

A multi-family building consists of four or more dwelling units that share common walls, and also may share common floors or ceilings. Multi-family buildings include apartments and dormitories.

## COMMON AREAS

Common areas include interior hallways, pool houses, reading rooms, and laundry rooms.



# PARKING LOTS & GARAGES

## LIGHTING STANDARDS

**Parking lots and carports** for seven or fewer cars per site must meet **Title 24, Part 6 Outdoor Residential Lighting Standards**.

**Parking garages**, either attached or detached from the dwelling unit, for seven or fewer cars per site must meet **Title 24, Part 6 Indoor Residential Lighting Standards**.

**Parking lots and garages** for eight or more vehicles per site must meet **Title 24, Part 6 Outdoor Nonresidential Lighting Standards**.

## RESIDENTIAL PARKING LOTS & GARAGES

A parking garage is a covered building or structure for the purpose of parking vehicles, and consists of at least a roof over the parking area enclosed with walls on all sides. Parking garages may have fences, rails, partial walls, or other barriers in place of one or more walls. If the roof of a parking structure also is used for parking, the section without an overhead roof is considered a parking lot.

## PARKING LOT LIGHTING TIPS

- Residential parking lots should be lit uniformly to provide a sense of safety. Lighting should fill in shadows and dark corners. Two or more less powerful luminaires in different places are preferable to a single luminaire.
- Fixture integrated sensors can maximize energy savings, ensuring lights are off when the space is unoccupied and offering high/low options when the space is occupied.



© CALIFORNIA LIGHTING TECHNOLOGY CENTER

# APPENDIX

<b>Compliance Checklist</b>	<b>44</b>
<b>Glossary</b>	<b>49</b>
<b>Resources &amp; Information</b>	<b>53</b>

# COMPLIANCE CHECKLIST

<input type="checkbox"/>	<b>Devices and Components Certified to the California Energy Commission</b>	<b>Any of the following installed devices and components must have been certified to the Energy Commission:</b> LED lighting systems classified as high efficacy, ballasts used in recessed luminaires, vacancy sensors, dimmers, track lighting, integral current limiters, and outdoor motion sensors.	<input type="checkbox"/> Yes <input type="checkbox"/> N/A
<input type="checkbox"/>	<b>Lighting Controls</b>	<b>Low-efficacy, high-efficacy separate switching</b> All permanently installed low-efficacy luminaires are controlled by switches separate from those controlling high-efficacy luminaires.	<input type="checkbox"/> Yes <input type="checkbox"/> N/A
		<b>Exhaust fans with integral lighting systems</b> Exhaust fans with integral lighting systems must be switched separately from lighting systems <b>OR</b> have a lighting system that can be manually turned on/off while allowing the fan to continue operation for an extended period of time.	<input type="checkbox"/> Yes <input type="checkbox"/> N/A
		<b>Readily accessible manual controls</b> All permanently installed luminaires are switched with readily accessible controls that permit the luminaires to be manually switched on and off.	<input type="checkbox"/> Yes <input type="checkbox"/> N/A
		<b>Manufacturer's instructions</b> All lighting controls must be installed in accordance with the manufacturer's instructions.	<input type="checkbox"/> Yes <input type="checkbox"/> N/A
		<b>No bypassing controls</b> No controls may bypass a dimmer or vacancy sensor function for all lighting circuits controlled by more than one switch with a dimmer or vacancy sensor installed.	<input type="checkbox"/> Yes <input type="checkbox"/> N/A

**Luminaires****High efficacy vs. low efficacy** Yes  N/A

High-efficacy and low-efficacy luminaire classification has been determined for each luminaire.

---

**Electronic ballasts for fluorescent lamps 13 W or greater** Yes  N/A

Fluorescent lamps rated 13W or greater must use electronic ballasts with an output frequency of no less than 20 kHz.

---

**Night-lights and lighting integral to exhaust fans** Yes  N/A

Permanently installed night-lights and night-lights integral to permanently installed luminaires or exhaust fans must contain only high-efficacy lamps, and must not contain a line-voltage socket or line-voltage lamp holder, **OR** the night-light must be rated to consume no more than 5W and must not contain a medium screw-base socket.

Lighting integral to exhaust fans must be controlled separately from the exhaust fans.

---

**Electrical boxes** Yes  N/A

An electrical box finished with a blank cover, or with no electrical equipment installed, that can be used for a luminaire or surface-mounted ceiling fan, must be considered a low-efficacy luminaire.

---

**Recessed luminaires in insulated ceilings** Yes  N/A

Luminaires that are recessed into insulated ceilings must meet all of the following conditions:

1. Must be listed for zero clearance insulation contact by UL or other nationally recognized testing/rating laboratory
2. Must have a label certifying the luminaire as airtight with air leakage less than 2.0 CFM at 75 Pascals when tested in accordance with ASTM E283.
3. Must be sealed with a gasket or caulk between the luminaire housing and ceiling. All air leak paths between conditioned and unconditioned space must be sealed with a gasket or caulk, including exhaust fan housings.
4. Must allow readily accessible ballast maintenance and replacement from below the ceiling without having to cut holes through the ceiling.

**Kitchens****Wattage calculations** Yes  N/A

All high-efficacy luminaires, **OR** at least 50% of total wattage must be used by high-efficacy luminaires.

**TABLE A: HIGH-EFFICACY WATTAGE IN KITCHEN**

High-efficacy Luminaire Type	Watts	x	Qty.	=	High-efficacy Watts
1.		x		=	
2.		x		=	
3.		x		=	
4.		x		=	
5.		x		=	
<b>Total A. High-efficacy Wattage:</b>					

**TABLE B: LOW-EFFICACY WATTAGE IN KITCHEN**

Low-efficacy Luminaire Type	Watts	x	Qty.	=	Low-efficacy Watts
1.		x		=	
2.		x		=	
3.		x		=	
4.		x		=	
5.		x		=	
<b>Total A. Low-efficacy Wattage:</b>					

**Note:** Low-efficacy wattage for electrical boxes finished with a blank cover, or with no electrical equipment installed, to be used as a luminaire or surface-mounted ceiling fan, are calculated as 180W of low-efficacy lighting per blank electrical box.

Code-compliant if **Total A** ≥ **Total B**

(high-efficacy wattage is more than low-efficacy wattage).



---

**Additional kitchen low-efficacy lighting** Yes  N/A

To qualify for additional kitchen low-efficacy lighting, all three of the following conditions must be met.

1. All low-efficacy luminaires in the kitchen are controlled by a vacancy sensor, dimmer, Energy Management Control Systems (EMCS), or multi-scene programmable control system.
2. Permanently installed luminaires in garages, closets larger than 70 ft<sup>2</sup>, laundry rooms, and utility rooms are high efficacy **AND** controlled by a vacancy sensor.
3. The total kitchen wattage for low-efficacy luminaires (Table B) does not exceed the total wattage for high-efficacy luminaires (Table A) and the additional wattage for low-efficacy luminaires (Table C) combined.

$$\text{Total B} \leq (\text{Total A} + \text{Total C})$$

**TABLE C: ADDITIONAL LOW-EFFICACY WATTAGE ALLOWED IN KITCHEN**

Dwelling unit size	Additional low-efficacy wattage	Total C (select one)
≤ 2,500 ft <sup>2</sup>	50 W	
≥ 2,500 ft <sup>2</sup>	100 W	

---

**Lighting internal to cabinets** Yes  N/A

Permanently installed lighting internal to cabinets uses ≤ 20W per linear foot of illuminated cabinet.

- 
- 
- Bathrooms, Garages, Closets > 70ft<sup>2</sup>, Laundry Rooms, & Utility Rooms**

Permanently installed luminaires in bathrooms, garages, closets larger than 70 ft<sup>2</sup>, laundry rooms, and utility rooms must be high-efficacy luminaires **OR** controlled by a vacancy sensor.

 Yes  N/A

- 
- 
- Other Rooms**
- (e.g., hallways, dining rooms, family rooms, home offices, bedrooms, attic spaces, wine cellars)

Permanently installed luminaires in rooms or areas other than kitchens, bathrooms, garages, closets larger than 70 ft<sup>2</sup>, laundry rooms, and utility rooms must be high-efficacy luminaires **OR** controlled by a dimmer switch **OR** controlled by a vacancy sensor.

 Yes  N/A

---

**Outdoor Lighting**  Yes  N/A

Luminaires providing outdoor lighting are high-efficacy luminaires **OR** controlled by a manual on/off switch **AND** a motion sensor without an override or bypass switch **AND** one of the following three control methods, without override or bypass switches:

1. Photocontrol
2. Astronomical time clock
3. Energy Management Control System (EMCS)

Permanently installed luminaires in or around swimming pools, spas, hot tubs, or fountains subject to Article 680 of the California Electrical Code do not need to be high efficacy..

---

**Override switch for low-efficacy luminaires**  Yes  N/A

Low-efficacy outdoor luminaires controlled by a motion sensor may have a temporary override switch to bypass the motion-sensing function. The motion sensor must be automatically reactivated within six hours. The luminaire must be controlled by a photocontrol, astronomical time clock, or EMCS, according to the outdoor lighting requirements.

---

**Internally illuminated address signs**  Yes  N/A

Internally illuminated address signs must comply with the *Title 24, Part 6* Address Sign Standards **OR** not contain a screw-base socket and consume no more than 5W.

---

**Multi-family Common Areas**  Yes  N/A

Permanently installed lighting in enclosed, non-dwelling spaces of low-rise residential buildings for four or more dwelling units must be high-efficacy luminaires **OR** controlled by occupant sensors.

---

**Parking Lots & Garages** **Parking lots for 7 or fewer vehicles**  Yes  N/A

Lighting for parking lots and carports with seven or fewer vehicles per site must comply with *Title 24, Part 6* Outdoor Residential Lighting Standards.

---

**Parking garages for 7 or fewer vehicles**  Yes  N/A

Lighting for parking garages for seven or fewer vehicles must comply with *Title 24, Part 6* Indoor Residential Lighting Standards.

# GLOSSARY

**A** **ACCESSIBLE:** Having access to, possibly requiring removal or opening of access panels, doors, or similar obstructions.

**APPROVAL BY THE COMMISSION:** Approval under Section 25402.1 of the Public Resources Code.

**ASTRONOMICAL TIME SWITCH:** A lighting control device that switches lights on or off at dusk or dawn, or at specified times of the day.

**B** **BATHROOM:** A room or area containing a sink used for personal hygiene, toilet, shower, or tub.

**C** **CARPORT:** A covered, open-sided structure used solely for the purpose of parking vehicles, consisting of a roof over the parking area. Carports typically are free standing or projected from the side of the building and are two or fewer car lengths deep.

**CHANDELIER:** A ceiling-mounted, close-to-ceiling, or suspended decorative luminaire that uses glass, crystal, ornamental metals, or other decorative materials. Typically used as a significant element of interior architecture.

**CLOSET:** A non-habitable room used to store linens, household supplies, clothing, non-perishable food, or similar uses, which is not a hallway or passageway. *Title 24, Part 6* applies only to closets larger than 70 ft<sup>2</sup>.

**CALIFORNIA ENERGY COMMISSION:** The California State Energy Resources Conservation and Development Commission.

**D** **DIMMING, CONTINUOUS:** A lighting control method that is capable of varying the light output of lamps over a gradual range from full light output to off.

**DIMMING, STEPPED:** A lighting control method that varies the light output of lamps in one or more predetermined discrete levels between full light output and off.

**DINING AREA:** An area or room where meals are eaten. May be attached to the kitchen or in a separate space.

**E** **ELECTRICAL BOX:** A plastic or metal container for electrical circuits where the main electrical service from the grid is distributed throughout the building. Also called a junction box or electrical junction box.

**EFFICACY, LAMP:** The quotient of rated initial lamp output (lumens) divided by the rated lamp power (watts), without including auxiliaries such as ballasts, transformers, and power supplies. Efficacy indicates how much light is produced by a lamp or lighting system for the amount of electrical power consumed.

**ENERGY MANAGEMENT CONTROL SYSTEM (EMCS):** A computerized control system designed to regulate the energy consumption of a building by controlling the operation of an energy-consuming system. The EMCS is capable of monitoring environmental and system loads, adjusting operations to optimize energy usage, and responding to demand response signals.

**EXHAUST FAN:** A fan in a wall or ceiling that moves air from within a building to outside the building. Commonly located in bathrooms and kitchens.

**F** **FLUORESCENT:** A low-pressure mercury electric-discharge lamp in which a phosphor coating transforms some of the UV energy generated into visible light.

**G** **GARAGE:** A non-habitable building or portion of a building, attached to or detached from a residential dwelling unit, in which motor vehicles are parked.

**GENERAL LIGHTING:** Lighting designed to provide a substantially uniform level of illumination throughout an area, exclusive of any provision for special visual tasks or decorative effect. When designed for a lower-than-task illuminance used in conjunction with other specific task lighting systems, general lighting may be called ambient lighting.

**GU-24:** A lamp holder and socket configuration, based on a coding system by the International Energy Consortium, where “G” stands for the broad type of two or more projecting contacts (such as pins or posts), “U” distinguishes between lamp and holder designs of similar but not interchangeable types, and “24” indicates 24 millimeters center to center spacing of the electrical contact posts.

**H** **HID:** High intensity discharge lamp such as metal halide or high pressure sodium.

**HIGH-EFFICACY LUMINAIRES:** A luminaire meeting the wattage and minimum lumen requirements in Tables 1 and 2 on page 10. High-efficacy luminaires contain only high-efficacy lamps or high-efficacy LED lighting, and must not contain a socket that allows any low-efficacy lighting system to be used.

**HIGH-RISE RESIDENTIAL BUILDING:** A building, other than a hotel/motel, of Occupancy Group R, Division 1, with four or more habitable stories.

**I** **INCANDESCENT LAMP:** An electric lamp in which a filament gives off light when heated by an electric current.

**K** **KITCHEN:** A room or area with cooking facilities and/or an area where food is prepared.

**L** **LAMP:** The lighting industry’s term for a light bulb.

**LAUNDRY ROOM:** A non-habitable room or space that contains plumbing and electrical connections for a washing machine and/or clothes dryer.

**LIGHT EMITTING DIODE (LED):** A PN junction semiconductor device that emits incoherent optical radiation when biased in the forward direction. The acronym LED typically refers to an LED component, device, or package.

**HYBRID LED LUMINAIRE:** A complete lighting unit consisting of both an LED light source and a non-LED light source.

**LED LAMP:** An LED component, device, or package, and other optical, thermal, mechanical, and electrical (control circuitry) components with an integrated LED driver (power source) and a standardized base that is designed to connect to the branch circuit via standardized base, lamp holder, or socket.

**LED LUMINAIRE:** A complete LED lighting unit consisting of a light source and driver together with parts to distribute light, to position and protect the light source, and to connect the light source to a branch circuit. The light source itself may be an LED component, package, device, array, module, source system, or lamp. The LED luminaire is intended to be connected directly to a branch circuit.

**LINE-VOLTAGE:** Line-voltage sockets pair with a variety of screw, pin, and bayonet bases (also called holders). Line-voltage sockets do not include a transformer, ballast, or power supply between the wires connected to the luminaire and the lamp. Only GU-24 line voltage luminaires can qualify as high efficacy under *Title 24, Part 6*.

**LOW EFFICACY:** A low-efficacy luminaire is one that does not meet the qualifications for high efficacy, or contain any type of line-voltage socket or lamp holder capable of accepting a low-efficacy lamp, track lighting, incandescent lighting, conversions between screw-base and pin-base sockets, electrical boxes used for a luminaire or ceiling fan, or uncertified LED light source or GU-24 base.

**LOW-RISE RESIDENTIAL BUILDING:** A building, other than a hotel/motel, that is of Occupancy Group R, Division 1, and is multi-family with three habitable stories or less; or a single-family residence of Occupancy Group R, Division 3; or an Occupancy Group U building located on a residential site.

**LUMEN:** The unit of measurement of the amount of light, also known as luminous flux, produced by a light source.

**LUMINAIRE:** A complete lighting unit consisting of a lamp and the parts designed to distribute the light (lens, reflector), to position and protect the lamp (housing), and to connect the lamp to the power supply (ballast, transformer). Also referred to as a lighting fixture or light fixture.

**M MOTION SENSOR:** A device that automatically turns lights off soon after an area is vacated. Motion sensor applies to a device that controls outdoor lighting systems. When the device is used to control indoor lighting systems, it is called an occupant sensor. The device often also is called an occupancy sensor, occupant-sensing device, or vacancy sensor.

**MULTI-LEVEL LIGHTING CONTROL:** A lighting control that reduces lighting power in multiple steps while maintaining a reasonably uniform level of illuminance throughout the area controlled.

**MULTI-FAMILY BUILDING:** A building containing multiple dwelling units that share common walls and also may share common floors or ceilings (apartments and dorms).

**MULTI-SCENE PROGRAMMABLE SWITCH:** A lighting control device that has the capability of setting light levels throughout a continuous range, and has pre-established settings within the range.

**N NOOK:** An area adjacent to the kitchen not on the same switch. Falls under *Title 24, Part 6* Other Spaces Residential Lighting Standards, not under wattage requirements for kitchens.

**O OCCUPANT SENSOR:** A device that automatically turns lights off soon after an area is vacated. The term occupant sensor applies to a device that controls indoor lighting systems. When used to control outdoor lighting systems, it is called a motion sensor. Also may be called an occupancy-sensing device, occupancy sensor, or vacancy sensor.

**OTHER ROOMS:** Includes any room or area that is not a kitchen, bathroom, garage, closet larger than 70 ft<sup>2</sup>, laundry room, or utility room (e.g., hallway, dining room, family room, home office, bedroom, attic space, wine cellar).

**OUTDOOR LIGHTING, RESIDENTIAL:** Permanently installed luminaires that provide lighting for private patios, entrances, balconies, and porches. Permanently installed luminaires in or around swimming pools, water features, or other locations subject to Article 680 of the California Electrical Code do not need to be high efficacy.

**P PARKING AREA:** The area of a parking garage used for parking and maneuvering vehicles on a single floor, and which is not the roof of a parking structure.

**PARKING GARAGE:** A covered building or structure for the purpose of parking vehicles. Consists of at least a roof over the parking area enclosed with walls on all sides. May have fences, rails, partial walls, or other barriers in the place of walls. Parking garages have entrances and exits, and include space for vehicle maneuvering to reach the parking spaces. If the roof of a parking structure also is used for parking, the section without an overhead roof is considered a parking lot instead of a parking garage.

**PARKING LOT:** An uncovered area for the purpose of parking vehicles.

**PENDANT:** A device in which the luminaire is suspended from above.

**PERMANENTLY INSTALLED LIGHTING:** All luminaires attached to the inside or outside of a building site, including track and flexible lighting systems; lighting attached to walls, ceilings, columns, inside or outside of permanently installed cabinets, internally illuminated case work, mounted on poles, in trees, or in the ground; attached to ceiling fans and integral to exhaust fans that are other than exhaust hoods for cooking equipment. Does not include portable lighting or lighting that is installed by the manufacturer in appliances.

**PHOTOCONTROL:** An electric device that detects changes in illumination levels, then controls lighting load at predetermined illumination levels. For example, automatically turning fixtures on at dusk and turning them off at dawn.

**PIN-BASE FIXTURE:** A fixture that accepts lamps with a pin base, which performs the same function as the screw base, but with higher efficiency. GU-24 pin-base fixtures are meant to prevent the use of low-efficacy lamps.

**PORTABLE LIGHTING:** Lighting with plug-in connections for electric power that is table and freestanding floor lamps, attached to modular furniture, workstation task lights, lights attached to workstation panels, movable displays, and other luminaires that are not permanently installed.

**R** **READILY ACCESSIBLE:** Capable of being reached quickly for operation, repair, or inspection, without climbing or removing obstacles, or resorting to using portable access equipment.

**RESIDENTIAL COMPLIANCE MANUAL:** The *Residential Compliance Manual* was developed by the California Energy Commission, under section 25402.1 of the Public Resources Code, to aid designers, builders, and contractors in meeting the *2008 Title 24 Building Energy Efficiency Standards* for low-rise residential buildings.

**RESTROOM:** A room or suite of rooms providing personal facilities such as toilets and sinks.

**S** **SCREW-BASE FIXTURE:** A fixture that accepts lamps with a screw base, e.g., incandescent lamps and CFL lamps. Screw-base fixtures are treated as low efficacy under *Title 24, Part 6*.

**SCONCE:** A wall-mounted ornamental luminaire.

**STAIRS:** A series of steps providing passage from one level of a building to another.

**STORAGE BUILDING:** A non-habitable detached building used to store tools, garden equipment, or miscellaneous items.

**T** **TASK LIGHTING:** Lighting that is designed specifically to illuminate a task location, and that is generally confined to the task location.

**U** **UTILITY ROOM:** A non-habitable room or building that contains only HVAC, plumbing, or electrical controls or equipment; not a bathroom, closet, garage, or laundry room.

**V** **VACANCY SENSOR:** An occupant sensor for which the lights must be manually turned on, which automatically turns the lights off soon after an area is vacated. The device also may be called a manual-on occupant sensor, or manual-on/automatic off sensor.

**W** **WATT:** The unit of measure for the electric power used by a lamp or fixture.

# RESOURCES & INFORMATION

## **CALIFORNIA LIGHTING TECHNOLOGY CENTER**

[cltc.ucdavis.edu/title24](http://cltc.ucdavis.edu/title24)

The *Residential Lighting Design Guide* was developed by the California Lighting Technology Center, UC Davis. CLTC was established through a joint effort of the California Energy Commission and the University of California, Davis to develop and test state-of-the-art lighting and daylighting applications. CLTC also offers training and educational programs on energy-efficient lighting.

## **ENERGY STANDARDS HOTLINE**

**Toll-free in California: (800) 772-3300**

[title24@energy.state.ca.us](mailto:title24@energy.state.ca.us)

The Energy Standards Hotline is a resource for any questions regarding the *2008 Title 24 Building Energy Efficiency Standards*. The hotline is available Monday through Friday, 8 a.m.–12 p.m. and 1–4:30 p.m.

## **2008 TITLE 24 BUILDING ENERGY EFFICIENCY STANDARDS**

[www.energy.ca.gov/title24](http://www.energy.ca.gov/title24)

The *2008 Title 24 Building Energy Efficiency Standards* is available as a PDF on the Energy Commission website. It includes the standards for residential lighting, along with standards for all other residential applications. The standards should be the first resource for any contractor, builder, or designer seeking *Title 24, Part 6* regulations.

## **2008 TITLE 24 BUILDING ENERGY EFFICIENCY STANDARDS RESIDENTIAL COMPLIANCE MANUAL**

[www.energy.ca.gov/title24/2008standards/residential\\_manual.html](http://www.energy.ca.gov/title24/2008standards/residential_manual.html)

The California Energy Commission created the *2008 Title 24 Building Energy Efficiency Standards Residential Compliance Manual* to supplement *Title 24, Part 6*. The *Residential Compliance Manual* clarifies issues not addressed in the standards.

## **TITLE 24 ONLINE LEARNING CENTER**

[www.title24learning.com](http://www.title24learning.com)

The Online Learning Center provides a comprehensive educational program for the *2008 Title 24 Building Energy Efficiency Standards*. It has helpful video lessons, transcripts, and tests to assist consumers, builders, contractors, plans examiners, and enforcement agencies in understanding the standards.

## **CALIFORNIA ENERGY COMMISSION APPLIANCE EFFICIENCY DATABASE**

[www.appliances.energy.ca.gov](http://www.appliances.energy.ca.gov)

The Appliance Efficiency Database contains all fixtures, systems, lamps, and devices currently certified to the California Energy Commission by their manufacturers as meeting applicable efficiency standards. The database features a categorized search for each type of appliance in the database.



**FOR MORE INFORMATION ABOUT *TITLE 24, PART 6*,  
VISIT THE CLTC WEBSITE AT  
[cltc.ucdavis.edu/title24](http://cltc.ucdavis.edu/title24)**