

MARCH 2017

CITY OF TRACY
STORMWATER MANAGEMENT PROGRAM

Construction Erosion and Sediment Control Plan Applicant Package



Think Inside the Triangle™



City of Tracy Construction Erosion and Sediment Control Plan Applicant Package

Contents

Erosion and Sediment Control Plan (ESCP) Applicant Guidance

- Section 1 Project Information
- Section 2 Applicant Information
- Section 3 Identify Other Required Permits
- Section 4 Site Plan and BMP Implementation Schedule
- Section 5 BMP Information

City of Tracy ESCP Standard Template

City of Tracy Minimum Control Measures for Small Construction Projects

City of Tracy Trench Dewatering BMPs

The City of Tracy would like to give special thanks to MCSTOPPP for allowing the use of their documents and materials for this plan.



Erosion and Sediment Control Plan

Applicant Guidance

For **projects that will include soil disturbance during construction**, applicants must submit an Erosion and Sediment Control Plan (ESCP) for approval by the Utilities Department prior to the issuance of certain permits, including all Grading Permit, most Building Permits, and other permits at the discretion of the municipality.

The purpose of the ESCP is to:

1. Identify potential pollutant sources that may affect the quality of stormwater runoff discharges from the construction site.
2. Document the Best Management Practices (BMPs) that will be implemented and placed in order to prevent, to the maximum extent practicable, construction site pollutants from leaving the site and entering the storm drain system during all phases of construction.
3. Document erosion control, sediment control, and good housekeeping BMPs that must be implemented year round as appropriate based on construction activities.

The ESCP may require modification as the project progresses and as conditions warrant. All modifications to the approved ESCP must be submitted to the municipality for review and approval.

The attached template should be used by applicants to develop the ESCP. The following checklist provides guidance to help complete the ESCP. If a project disturbs one acre or more of soil, it is subject to the State’s Construction General Permit¹ (CGP). In this circumstance, the Stormwater Pollution Prevention Plan (SWPPP) developed pursuant to the CGP may substitute for the ESCP.

Applicants should not complete or write in the Official Use Only sections of the template. Pages 1 and 2 provide space for the agency staff to document complete tracking information and to document comments on the ESCP.

Section 1 Project Information

A	Project Name	Applicant’s name for the project.
B	Tract Number	Property tract number.
C	Assessor’s Parcel Number	Assessor’s parcel number (APN).
D	Location (address as assigned by Planning Department)	Describe the location such that field staff can find the project site. Generally the project address, but in cases where an address has not been assigned milepost markers, cross streets, or latitude and longitude can be used.
E	Name and distance to nearest waterbody	Identify the name of the nearest river, stream or other waterbody as well as the approximate distance from the project site.

¹ Water Quality Order 2009-009-DWQ, as amended.

F	Area of Disturbance (in acres or square feet)	The total area** that will be subject to soil disturbing activities. Soil disturbing activities include, but are not limited to, clearing, grading, paving, disturbances to ground such as stockpiling, and excavation. **Note if the total area of disturbance is one acre (43,560 square feet) or more, the project is subject to the State's Construction General Permit.
G	Total Project Size (in acres or square feet)	This is the total size of the project, typically the size of the parcel(s). The total size of the project can exceed the total area of disturbance.
H	Planned Project Start Date	The date when construction activity will commence. If the date changes notify the agency. In some cases date changes may require updates to the ESCP, e.g., change of project from summer to winter construction. Also, if the project is subject to the CGP, you must update your Notice of Intent.
I	Planned Grading Completion Date	The grading and/or ground disturbing operations will be completed. This date may be the same as the project completion date, but grading is frequently completed before structure interiors are completed. If the date changes notify the agency. In some cases date changes may require the applicant to update the ESCP, e.g., change of project from summer to winter grading. Also, if the project is subject to the CGP, you must update your Notice of Intent.
J	Planned Project Completion Date	The date when the project will be completed. Project completion means 70% of all disturbed soils have been stabilized, all construction activities are complete, and all construction materials and wastes have been removed from the site. If the date changes notify the agency. In some cases date changes may require the applicant to update the ESCP, e.g., change of project from summer to winter construction. Also, if the project is subject to the CGP, you must update your Notice of Intent.
K	Project Description and Purpose	Narrative description of the project: should include the nature of the construction activities and why the project is being undertaken, and the project phase. If requested, provide photographs of the project to document the pre-project condition.

Section 2 Applicant Information

A	Project Owner (Name, Address, Phone)	Contact information for the land owner.
B	Contractor (Name, Address, Phone, 24/7 Contact Number)	Contact information for the person or company performing the work. In cases where the land owner is performing the work, list the land owner. Provide a 24/7 number in case of off-hours emergencies.
C	Applicant Certification	If required by the municipality, complete the Certification Statement. Confirm with the municipality whether the contractor or the owner must sign the statement.

Section 3 Identify Other Required Permits

Identify whether other permits that affect water courses or water quality are required. Applicants must provide proof the necessary permits have been applied for and obtained. Grading or Building Permits will not be issued until proof is submitted that these other permits have been obtained.

A	Construction General Permit (CGP)	Issued by the State Water Resources Control Board for construction activities that disturb one acre or more of land and in some cases for smaller projects that are part of a common plan of development. For more information see: http://www.swrcb.ca.gov/water_issues/programs/stormwater/construction.shtml
B	Section 404 Permit	Issued by the U.S. Army Corps of Engineers, Sacramento District for projects affecting waters of the U.S., including wetlands. For more information see: http://www.spk.usace.army.mil/Missions/Regulatory/
C	Section 401 Water Quality Certification	In most cases this is a companion permit issued by the Central Valley Regional Water Quality Control Board whenever the U.S. Army Corps of Engineers issues a Section 404 Permit to ensure state water quality standards are protected. Occasionally, the Central Valley Regional Water Quality Control Board will issue Waste Discharge Requirements in lieu of a Section 401 Certification. For more information see: http://www.waterboards.ca.gov/water_issues/programs/cwa401/
D	Streambed/Lake Alteration Agreement (1600 Agreements)	The California Department of Fish and Wildlife issues Streambed Alteration Agreements for projects that will affect a stream or lake. In general, an agreement will be required for any work that will obstruct or divert the natural flow of a river, stream, or lake; change or use any material from the bed, channel, or bank of a river, stream, or lake; or deposit or dispose of debris, waste where it can pass into a river, stream, or lake. For more information see: http://www.dfg.ca.gov/habcon/1600/

Section 4 Site Plan and BMP Implementation Schedule

A	Site Plan	List the plan sheet(s) that show the project site and scope of construction activity. Site plan sheets need to conform to agency requirements (e.g., size, scale) for site plan submitted for Grading and Building Permits. The site plan and project description in the Project Description section of the ESCP need to agree.
B	BMP Locations	List the plan sheet(s) that show the locations of proposed construction activity BMPs. Some BMPs may be included as notes on the site plan. In addition to BMPs, show required local creek setbacks and preserved existing vegetation on the site plan.

C	BMP Implementation Schedule	Identify schedule for BMP implementation with the commencement of the construction activities and that BMPs will be implemented year round, as appropriate, until the project is complete. Include final site stabilization in the schedule
---	-----------------------------	---

Section 5 BMP Information

At minimum the ESCP must include the applicable City of Tracy minimum erosion control, sediment control, and good housekeeping BMPs listed below. The ESCP must provide a rationale for the selected BMPs including, if needed, soil loss calculations.

Minimum BMPs are further described in the City of Tracy Minimum Control Measures for Small Construction Projects factsheet (attached).

Applicants may need to consider BMPs beyond the minimum control measures if warranted by site conditions and planned construction activities. If dewatering will occur applicants need to follow the City of Tracy Trench Dewatering BMPs factsheet (attached).

Projects subject to other permits (e.g., CGP, Section 404 Permit) must address the minimum City of Tracy control measures as well as the BMPs required by the other permit(s).

	BMP	General Description
	<u>Erosion Control BMPs</u>	
A	Scheduling	Plan the project and develop a schedule showing each phase of construction. Schedule construction activities to reduce erosion potential, such as scheduling ground disturbing activities during the summer and phasing projects to minimize the amount of area disturbed. CASQA: EC-1; or Caltrans: SS-1.
B	Preserve Existing Vegetation and Creek Setbacks	Preserve existing vegetation to the extent possible, especially along creek buffers. Show creek buffers on maps and identify areas to be preserved in the field with temporary fencing. Check with the local Planning and Public Works Departments for specific creek set back requirements. CASQA: EC-2; or Caltrans: SS-2.
C	Soil Cover	Cover all exposed soil with straw mulch and tackifier (or equivalent). CASQA: EC-3, EC-5, EC-6, EC-7, EC-8, EC-14, and EC-16. Caltrans: SS-2, SS-4, SS-5, SS-6, SS-7, SS-8.
D	Soil Preparation/ Roughening	Soil preparation is essential to vegetation establishment and BMP installation. It includes soil testing and amendments to promote vegetation growth as well as roughening surface soils by mechanical methods (decompacting, scarifying, stair stepping, etc.). CASQA: EC-15.
	Erosion Control Blankets	Install erosion control blankets (or equivalent) on any disturbed site with 3:1 slopes or steeper, keyed into the ground at least 3 inches. Use wildlife-friendly blankets made of biodegradable natural materials. Avoid using blankets made with plastic netting or fixed aperture netting. See: http://www.coastal.ca.gov/nps/Wildlife-Friendly_Products.pdf . CASQA: EC-7. Caltrans: SS-7.

	BMP	General Description
	<u>Erosion Control BMPs</u>	
F	Revegetation	Re-vegetate areas of disturbed soil or vegetation as soon as practical. CASQA: EC-4. Caltrans: SS-4.
G	Tracking Controls	Stabilize site entrance to prevent tracking soil offsite. Inspect streets daily and sweep street as needed. Require vehicles and workers to use stabilized entrance. Place crushed rock 12-inches deep over a geotextile, using angular rock between 4 and 6-in. Make the entrance as long as can be accommodated on the site, ideally long enough for 2 revolutions of the maximum tire size (16-20 feet long for most light trucks). Make the entrance wide enough to accommodate the largest vehicle that will access the site, ideally 10 feet wide with sufficient radii for turning in and out of the site. Rumble pads or rumble racks can be used in lieu of or in conjunction with rock entrances. Wheel washes may be needed where space is limited or where the site entrance and sweeping is not effective. CASQA: TC-1; TC-3; or Caltrans: TC-1; TC-3.
H	Fiber Rolls	Use fiber rolls as a perimeter control measure, along contours of slopes, and around soil stockpiles. On slopes space rolls 10 to 20 feet apart (using closer spacing on steeper slopes). Install parallel to contour. If more than one roll is used in a row overlap roll do not abut. J-hook end of roll upslope. Install rolls per either Type 1 (stake rolls into small trenches) or Type 2 (stake in front and behind roll and lash with rope). Use wildlife-friendly fiber rolls made of biodegradable natural materials. Avoid using fiber rolls made with plastic netting or fixed aperture netting. See: http://www.coastal.ca.gov/nps/Wildlife-Friendly_Products.pdf . Manufactured linear sediment control or compost socks can be used in lieu of fiber rolls. CASQA: SE-5 (Type 1); SE-12, SE-13; or Caltrans: SC-5 (Type 1 and Type 2).
I	Silt Fence	Use silt fence as a perimeter control measure, and around soil stockpiles. Install silt fence along contours. Key silt fence into the soil and stake. Do not use silt fence for concentrated water flows. Install fence at least 3 feet back from the slope to allow for sediment storage. Wire backed fence can be used for extra strength. Avoid installing silt fence on slopes because they are hard to maintain. Manufactured linear sediment control can be used in lieu of silt fences. CASQA: SE-1; SE-12; or Caltrans: SC-1.

² More detailed information on the BMPs can be found in the related California Stormwater Quality Association (CASQA) California Department of Transportation (Caltrans) BMP Factsheets. CASQA factsheets are available by subscription in the *California Best Management Practices Handbook Portal: Construction* at <http://www.casqa.org>. Caltrans factsheets are available in the Construction Site BMP Manual March 2003 at <http://www.dot.ca.gov/hq/construc/stormwater/manuals.htm>.

	BMP	General Description²
<u>Sediment Control BMPs</u>		
J	Drain Inlet Protection	Use gravel bags, (or similar product) around drain inlets located both onsite and in gutter as a last line of defense. Bags should be made of a woven fabric resistant to photo-degradation filled with 0.5-1-in washed crushed rock. Do not use sand bags or silt fence fabric for drain inlet protection. CASQA: SE-10; or. Caltrans: SC-10.
K	Trench Dewatering	Follow CITY OF TRACY BMPs for trench dewatering. (Attached) CASQA: NS-2. Caltrans: NS-2.
<u>Good Housekeeping BMPs</u>		
L	Concrete Washout	Construct a lined concrete washout site away from storm drains, waterbodies, or other drainages. Ideally, place adjacent to stabilized entrance. Clean as needed and remove at end of project. CASQA: WM-8. Caltrans: WM-8.
M	Stockpile Management	Cover all stockpiles and landscape material and berm properly with fiber rolls or sand bags. Keep behind the site perimeter control and away from waterbodies. CASQA: WM-3. Caltrans: WM-3.
N	Hazardous Material Management	Hazardous materials must be kept in closed containers that are covered and within secondary containment, do not place containers directly on soil. CASQA: WM-6. Caltrans: WM-6.
O	Sanitary Waste Management	Place portable toilets near stabilized site entrance, behind the curb and away from gutters, storm drain inlets, and waterbodies. Tie or stake portable toilets to prevent tipping and equip units with overflow pan/tray (most vendors provide these). CASQA: WM-9. Caltrans: WM-9.
P	Equipment and Vehicle Maintenance	Prevent equipment fluid leaks onto ground by placing drip pans or plastic tarps under equipment. Immediately clean up any spills or drips. CASQA: NS-8, NS-9, and NS-10. Caltrans: NS-8, NS-9, and NS-10.
Q	Litter and Waste Management	Designate waste collection areas on site. Use watertight dumpsters and trash cans; inspect for leaks. Cover at the end of each work day and when it is raining or windy. Arrange for regular waste collection. Pick up site litter daily. CASQA: WM-5; or Caltrans: WM-5.
R	Other	Identify any additional BMPs that will be implemented for the project.



Think Inside the Triangle™

CITY OF TRACY ESCP Standard Template



Erosion and Sediment Control Plan

1. Project Information

Official Use Only	Applicant Complete this Section
Yes No Comments	
A <input type="checkbox"/> <input type="checkbox"/> <input type="checkbox"/>	Project Name:
B <input type="checkbox"/> <input type="checkbox"/> <input type="checkbox"/>	Tract Number
C <input type="checkbox"/> <input type="checkbox"/> <input type="checkbox"/>	Assessor's Parcel Number
D <input type="checkbox"/> <input type="checkbox"/> <input type="checkbox"/>	Location
E <input type="checkbox"/> <input type="checkbox"/> <input type="checkbox"/>	Name and Distance to Nearest Waterbody
F <input type="checkbox"/> <input type="checkbox"/> <input type="checkbox"/>	Area of Disturbance acres or square feet
G <input type="checkbox"/> <input type="checkbox"/> <input type="checkbox"/>	Total Project Size (acres or square feet)
H <input type="checkbox"/> <input type="checkbox"/> <input type="checkbox"/>	Planned Start Date
I <input type="checkbox"/> <input type="checkbox"/> <input type="checkbox"/>	Planned Grading Completion Date
J <input type="checkbox"/> <input type="checkbox"/> <input type="checkbox"/>	Planned Completion Date
K <input type="checkbox"/> <input type="checkbox"/> <input type="checkbox"/>	Project Description and Purpose

Continued on next page

Erosion and Sediment Control Plan

2. Applicant Information

Official Use Only	Applicant Complete this Section
Yes No Comments	
A	<input type="checkbox"/> <input type="checkbox"/> <input type="checkbox"/> Project Owner Name: _____ Address: _____ Phone: _____
B	<input type="checkbox"/> <input type="checkbox"/> <input type="checkbox"/> Contractor Name: _____ Address: _____ Phone: _____ (24/7 Number)
C	<input type="checkbox"/> <input type="checkbox"/> <input type="checkbox"/> Applicant Certification I certify that the information provided in the Erosion and Sediment Control Plan is, to the best of my knowledge and belief, true, accurate, and complete and that it will be implemented throughout the project. I further certify that I will notify the City of Tracy Utilities Department and submit revised information if any of the information or conditions documented in this Erosion and Sediment Control Plan change. I understand there are significant penalties for submitting false information or for not implementing the Erosion and Sediment Control Plan per the City of Tracy Stormwater Management Program. I will retain a copy of the Erosion and Sediment Control Plan at the project site and make it available at all times. Signature: _____ Print/Type _____ Name: _____ Title: _____ Date: _____

Continued on next page

Erosion and Sediment Control Plan

3. Identify Other Permits Required

Identify whether other permits that affect water courses or water quality are required. Attach proof the necessary permits have been applied for and obtained. Grading/Building permits will not be issued until proof is submitted that these other permits have been obtained.

Official Use Only			Applicant Complete this Section		
Yes	No	Comments	Permit/Agreement	Attached	
A	<input type="checkbox"/>	<input type="checkbox"/>	<input type="checkbox"/>	Construction General Permit (CGP) <input type="checkbox"/> Not Applicable <input type="checkbox"/> Applicable	<input type="checkbox"/> Proof of submission <input type="checkbox"/> Proof permit was obtained
B	<input type="checkbox"/>	<input type="checkbox"/>	<input type="checkbox"/>	Section 404 Permit <input type="checkbox"/> Not Applicable <input type="checkbox"/> Applicable	<input type="checkbox"/> Proof of submission <input type="checkbox"/> Proof permit was obtained
C	<input type="checkbox"/>	<input type="checkbox"/>	<input type="checkbox"/>	Section 401 Certification <input type="checkbox"/> Not Applicable <input type="checkbox"/> Applicable	<input type="checkbox"/> Proof of submission <input type="checkbox"/> Proof permit was obtained
D	<input type="checkbox"/>	<input type="checkbox"/>	<input type="checkbox"/>	Streambed/Lake Alteration Agreement (1600 Agreements) <input type="checkbox"/> Not Applicable <input type="checkbox"/> Applicable	<input type="checkbox"/> Proof of submission <input type="checkbox"/> Proof permit was obtained
E	<input type="checkbox"/>	<input type="checkbox"/>	<input type="checkbox"/>	Other: (Identify) <i>List any specific permits required by the local, state, federal, or regional agencies</i> <hr/> <hr/> <hr/> <hr/>	<input type="checkbox"/> Proof of submission <input type="checkbox"/> Proof permit was obtained

Continued on next page

Erosion and Sediment Control Plan

4. Site Plan and BMP Implementation Schedule

Attach a site plan(s) showing the locations and types of BMPs proposed. Provide an implementation schedule identifying the timing of temporary BMP installation and removal, as well as final BMP installation and final site stabilization. The schedule may be shown on the site plan(s) or as a separate document.

Official Use Only	Applicant Complete this Section	
Yes No Comments		
A <input type="checkbox"/> <input type="checkbox"/> <input type="checkbox"/>	Site Plan	List relevant plan sheets depicting site plan: the project site and scope of construction.
B <input type="checkbox"/> <input type="checkbox"/> <input type="checkbox"/>	BMP Locations	List relevant plan sheets depicting locations of proposed BMPs should be depicted. Some BMPs may be included as notes on the site plan. In addition to BMPs, show required local creek setbacks and preserved existing vegetation on the site plan.
C <input type="checkbox"/> <input type="checkbox"/> <input type="checkbox"/>	BMP Implementation Schedule:	Identify schedule for BMP implementation with the commencement of the construction activities and that BMPs will be implemented year round, as appropriate, until the project is complete. Include final site stabilization in the schedule.

Continued on next page

Erosion and Sediment Control Plan

5. BMP Information

Identify the BMPs that will be implemented for the project. At minimum the ESCP must include the CITY OF TRACY minimum erosion control, sediment control, and good housekeeping BMPs must be implemented. Provide a rationale for the selected BMPs, including if needed, soil loss calculations. Use the rationale to demonstrate that the selected control measures are appropriate site specific BMPs.

Official Use Only				Applicant Complete this Section	
Yes	No	Comments		BMP	Rationale
				Erosion Control BMPs	
A	<input type="checkbox"/>	<input type="checkbox"/>	<input type="checkbox"/>	Scheduling <i>(Schedule and plan activities to minimize exposed soil and avoid rainy weather.)</i>	<input type="checkbox"/> Yes <input type="checkbox"/> Not Applicable
B	<input type="checkbox"/>	<input type="checkbox"/>	<input type="checkbox"/>	Preserve Existing Vegetation and Creek Setbacks	<input type="checkbox"/> Yes <input type="checkbox"/> Not Applicable
C	<input type="checkbox"/>	<input type="checkbox"/>	<input type="checkbox"/>	Soil Cover <i>(Required, at a minimum, for graded or disturbed areas that are inactive for more than 14 days.)</i>	<input type="checkbox"/> Yes <input type="checkbox"/> Not Applicable

Continued on next page

Erosion and Sediment Control Plan

Official Use Only	Applicant Complete this Section
Yes No Comments	BMP Rationale
D <input type="checkbox"/> <input type="checkbox"/> <input type="checkbox"/>	Soil Preparation/ Roughening <i>(Required on graded slopes prior to installation of other BMPs as well as for final slope stabilization.)</i> <input type="checkbox"/> Yes <input type="checkbox"/> Not Applicable
E <input type="checkbox"/> <input type="checkbox"/> <input type="checkbox"/>	Erosion Control Blankets <input type="checkbox"/> Yes <input type="checkbox"/> Not Applicable
F <input type="checkbox"/> <input type="checkbox"/> <input type="checkbox"/>	Revegetation <i>(This is a temporary and/or permanent BMP that can include hydroseeding and final landscape plantings.)</i> <input type="checkbox"/> Yes <input type="checkbox"/> Not Applicable
Sediment Control BMPs	
G <input type="checkbox"/> <input type="checkbox"/> <input type="checkbox"/>	Stabilized Site Entrance <input type="checkbox"/> Yes <input type="checkbox"/> Not Applicable

Continued on next page

Erosion and Sediment Control Plan

Official Use Only				Applicant Complete this Section	
	Yes	No	Comments	BMP	Rationale
H	<input type="checkbox"/>	<input type="checkbox"/>	<input type="checkbox"/>	Fiber Rolls	<input type="checkbox"/> Yes <input type="checkbox"/> Not Applicable
I	<input type="checkbox"/>	<input type="checkbox"/>	<input type="checkbox"/>	Silt Fence	<input type="checkbox"/> Yes <input type="checkbox"/> Not Applicable
J	<input type="checkbox"/>	<input type="checkbox"/>	<input type="checkbox"/>	Drain Inlet Protection	<input type="checkbox"/> Yes <input type="checkbox"/> Not Applicable
K	<input type="checkbox"/>	<input type="checkbox"/>	<input type="checkbox"/>	Trench Dewatering	<input type="checkbox"/> Yes <input type="checkbox"/> Not Applicable

Continued on next page

Erosion and Sediment Control Plan

Official Use Only	Applicant Complete this Section
Yes No Comments	BMP Rationale
	Good Housekeeping BMPs
L <input type="checkbox"/> <input type="checkbox"/> <input type="checkbox"/>	Concrete Washout <input type="checkbox"/> Yes <input type="checkbox"/> Not Applicable
M <input type="checkbox"/> <input type="checkbox"/> <input type="checkbox"/>	Stockpile Management <input type="checkbox"/> Yes <input type="checkbox"/> Not Applicable
N <input type="checkbox"/> <input type="checkbox"/> <input type="checkbox"/>	Hazardous Material Management <input type="checkbox"/> Yes <input type="checkbox"/> Not Applicable
O <input type="checkbox"/> <input type="checkbox"/> <input type="checkbox"/>	Sanitary Waste Management (Placement of portable bathrooms and method of preventing spills.) <input type="checkbox"/> Yes <input type="checkbox"/> Not Applicable

Continued on next page

Erosion and Sediment Control Plan

Official Use Only	Applicant Complete this Section
	BMP Rationale
Yes No Comments	
P <input type="checkbox"/> <input type="checkbox"/> <input type="checkbox"/>	Equipment and Vehicle Maintenance <input type="checkbox"/> Yes <input type="checkbox"/> Not Applicable
Q <input type="checkbox"/> <input type="checkbox"/> <input type="checkbox"/>	Litter and Waste Management <input type="checkbox"/> Yes <input type="checkbox"/> Not Applicable
	Other BMPs List:
R <input type="checkbox"/> <input type="checkbox"/> <input type="checkbox"/>	<hr style="border: 0; border-top: 1px solid black; margin-bottom: 10px;"/> <input type="checkbox"/> Yes

Continued on next page

Erosion and Sediment Control Plan

Official Use Only			Applicant Complete this Section	
Yes	No	Comments	BMP	Rationale
<input type="checkbox"/>	<input type="checkbox"/>	<input type="checkbox"/>	<hr style="border: 0; border-top: 1px solid black; margin-bottom: 5px;"/> <input type="checkbox"/> Yes	
<input type="checkbox"/>	<input type="checkbox"/>	<input type="checkbox"/>	<hr style="border: 0; border-top: 1px solid black; margin-bottom: 5px;"/> <input type="checkbox"/> Yes	
<input type="checkbox"/>	<input type="checkbox"/>	<input type="checkbox"/>	<hr style="border: 0; border-top: 1px solid black; margin-bottom: 5px;"/> <input type="checkbox"/> Yes	
<input type="checkbox"/>	<input type="checkbox"/>	<input type="checkbox"/>	<hr style="border: 0; border-top: 1px solid black; margin-bottom: 5px;"/> <input type="checkbox"/> Yes	

Duplicate this page if needed to describe additional BMPs



CITY OF TRACY Minimum Control Measures for Small Construction Projects



City of Tracy Stormwater Pollution Prevention Program

Minimum Control Measures For Small Construction Projects

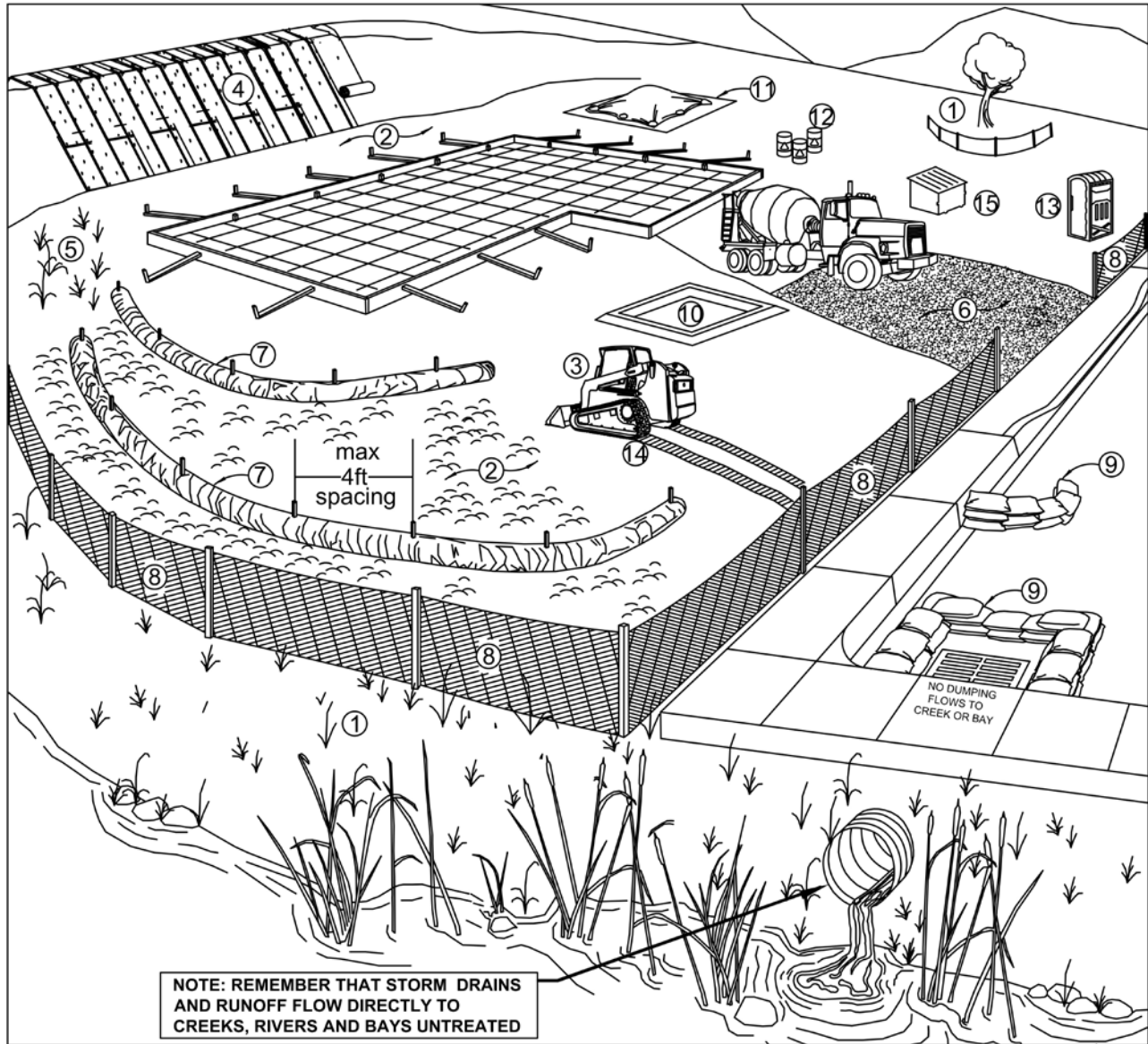

<u>Erosion Controls</u>	<u>Sediment Controls</u>	<u>Good Housekeeping</u>
NS Scheduling	6. Tracking Controls	10. Concrete Washout
1. Preserve Vegetation & Creek Set Backs	7. Fiber Rolls	11. Stockpile Management
2. Soil Cover	8. Silt Fence	12. Hazardous Material Management
3. Soil Preparation/ Roughening	9. Drain Inlet Protection	13. Sanitary Waste Management
4. Erosion Control Blankets	NS Trench Dewatering	14. Equipment and Vehicle Maintenance
5. Revegetation		15. Litter and Waste Management

NS=not shown on graphic

Note: Select an **effective combination of control measures from each category**, Erosion Control, Sediment Control, and Good Housekeeping. Control measures shall be **continually implemented and maintained throughout the project** until activities are complete, disturbed areas are stabilized with permanent erosion controls, and the local agency has signed off on permits that may have been required for the project. **Inspect and maintain the control measures** before and after rain events, and as required by the local agency or state permit.

More detailed information on the BMPs can be found in the related California Stormwater Quality Association (CASQA) and California Department of Transportation (Caltrans) BMP Factsheets. CASQA factsheets are available by subscription in the *California Best Management Practices Handbook Portal: Construction* at <http://www.casqa.org>. Caltrans factsheets are available in the *Construction Site BMP Manual March 2003* at <http://www.dot.ca.gov/hq/construc/stormwater/manuals.htm>. Visit www.CityofTracy.org for more information on construction site management and Erosion and Sediment Control Plans.

Control Measure		General Description
Erosion Control Best Management Practices		
N/A	Scheduling	Plan the project and develop a schedule showing each phase of construction. Schedule construction activities to reduce erosion potential, such as scheduling ground disturbing activities during the summer and phasing projects to minimize the amount of area disturbed. <i>For more info see the following factsheets: CASQA: EC-1; or Caltrans: SS-1.</i>
1	Preserve Existing Vegetation and Creek Setbacks	Preserve existing vegetation to the extent possible, especially along creek buffers. Show creek buffers on maps and identify areas to be preserved in the field with temporary fencing. Check with the local Planning and Public Works Departments for specific creek set back requirements. <i>For more info see the following factsheets: CASQA: EC-2; or Caltrans: SS-2.</i>
2	Soil Cover	Cover exposed soil with straw mulch and tackifier (or equivalent). <i>For more info see the following factsheets: CASQA: EC-3, EC-5, EC-6, EC-7, EC-8, EC-14, EC-16; or Caltrans: SS-2, SS-4, SS-5, SS-6, SS-7, SS-8.</i>
3	Soil Preparation/Roughening	Soil preparation is essential to vegetation establishment and BMP installation. It includes soil testing and amendments to promote vegetation growth as well as roughening surface soils by mechanical methods (decompacting, scarifying, stair stepping, etc.). <i>For more info see the following factsheets: CASQA: EC-15.</i>
4	Erosion Control Blankets	Install erosion control blankets (or equivalent) on disturbed sites with 3:1 slopes or steeper. Use wildlife-friendly blankets made of biodegradable natural materials. Avoid using blankets made with plastic netting or fixed aperture netting. See: http://www.coastal.ca.gov/nps/Wildlife-Friendly_Products.pdf . <i>For more info see the following factsheets: CASQA: EC-7; or Caltrans: SS-7.</i>
5	Revegetation	Re-vegetate areas of disturbed soil or vegetation as soon as practical. <i>For more info see the following factsheets: CASQA: EC-4; or Caltrans: SS-4.</i>
Sediment Control Best Management Practices		
6	Tracking Controls	Stabilize site entrance to prevent tracking soil offsite. Inspect streets daily and sweep street as needed. Require vehicles and workers to use stabilized entrance. Place crushed rock 12-inches deep over a geotextile, using angular rock between 4 and 6-in. Make the entrance as long as can be accommodated on the site, ideally long enough for 2 revolutions of the maximum tire size (16-20 feet long for most light trucks). Make the entrance wide enough to accommodate the largest vehicle that will access the site, ideally 10 feet wide with sufficient radii for turning in and out of the site. Rumble pads or rumble racks can be used in lieu of or in conjunction with rock entrances. Wheel washes may be needed where space is limited or where the site entrance and sweeping is not effective. <i>For more info see the following factsheets: CASQA: TC-1; TC-3; or Caltrans: TC-1; TC-3.</i>
7	Fiber Rolls	Use fiber rolls as a perimeter control measure, along contours of slopes, and around soil stockpiles. On slopes space rolls 10 to 20 feet apart (using closer spacing on steeper slopes). Install parallel to contour. If more than one roll is used in a row overlap roll do not abut. J-hook end of roll upslope. Install rolls per either Type 1 (stake rolls into shallow trenches) or Type 2 (stake in front and behind roll and lash with rope). Use wildlife-friendly fiber rolls made of biodegradable natural materials. Avoid using fiber rolls made with plastic netting or fixed aperture netting. See: http://www.coastal.ca.gov/nps/Wildlife-Friendly_Products.pdf . Manufactured linear sediment control or compost socks can be used in lieu of fiber rolls. <i>For more info see the following factsheets: CASQA: SE-5 (Type 1); SE-12, SE-13; or Caltrans: SC-5 (Type 1 and Type 2).</i>
8	Silt Fence	Use silt fence as a perimeter control measure, and around soil stockpiles. Install silt fence along contours. Key silt fence into the soil and stake. Do not use silt fence for concentrated water flows. Install fence at least 3 feet back from the slope to allow for sediment storage. Wire backed fence can be used for extra strength. Avoid installing silt fence on slopes because they are hard to maintain. Manufactured linear sediment control can be used in lieu of silt fences. <i>For more info see the following factsheets: CASQA: SE-1; SE-12; or Caltrans: SC-1.</i>
9	Drain Inlet Protection	Use gravel bags, (or similar product) around drain inlets located both onsite and in gutter as a last line of defense. Bags should be made of a woven fabric resistant to photo-degradation filled with 0.5-1-in washed crushed rock. Do not use sand bags or silt fence fabric for drain inlet protection. <i>For more info see the following factsheets: CASQA: SE-10; or Caltrans: SC-10.</i>
N/A	Trench Dewatering	Follow CITY OF TRACY BMPs for trench dewatering. <i>For more info see the following factsheets: CASQA: NS-2; or Caltrans: NS-2.</i>
Good Housekeeping Best Management Practices		
10	Concrete Washout	Construct a lined concrete washout site away from storm drains, waterbodies, or other drainages. Ideally, place adjacent to stabilized entrance. Clean as needed and remove at end of project. <i>For more info see the following factsheets: CASQA: WM-8; or Caltrans: WM-8.</i>
11	Stockpile Management	Cover all stockpiles and landscape material and berm properly with fiber rolls or sand bags. Keep behind the site perimeter control and away from waterbodies. <i>For more info see the following factsheets: CASQA: WM-3 or Caltrans: WM-3.</i>
12	Hazardous Material Management	Hazardous materials must be kept in closed containers that are covered and within secondary containment; do not place containers directly on soil. <i>For more info see the following factsheets: CASQA: WM-6; or Caltrans: WM-6.</i>
13	Sanitary Waste Management	Place portable toilets near stabilized site entrance, behind the curb and away from gutters, storm drain inlets, and waterbodies. Tie or stake portable toilets to prevent tipping and equip units with overflow pan/tray (most vendors provide these). <i>For more info see the following factsheets: CASQA: WM-9; or Caltrans: WM-9.</i>
14	Equipment and Vehicle Maintenance	Prevent equipment fluid leaks onto ground by placing drip pans or plastic tarps under equipment. Immediately clean up any spills or drips. <i>For more info see the following factsheets: CASQA: NS-8, NS-9, and NS-10; or Caltrans: NS-8, NS-9, and NS-10.</i>
15	Litter and Waste Management	Designate waste collection areas on site. Use watertight dumpsters and trash cans; inspect for leaks. Cover at the end of each work day and when it is raining or windy. Arrange for regular waste collection. Pick up site litter daily. <i>For more info see the following factsheets: CASQA: WM-5; or Caltrans: WM-5.</i>

Notes:

1. Mats/blankets should be installed vertically downslope
2. Staple blankets sufficiently to ensure that material will maintain direct contact with soil

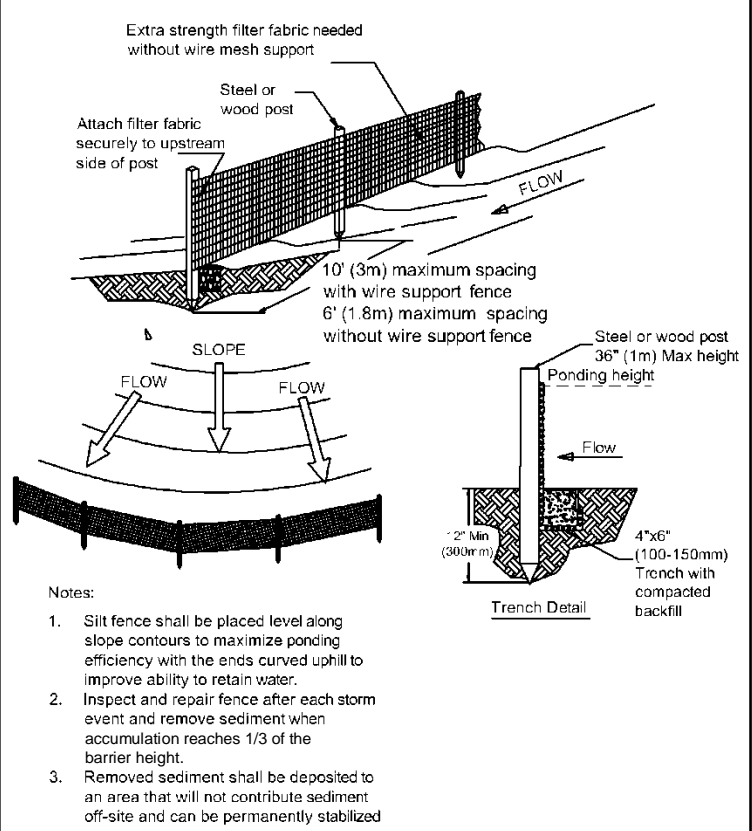
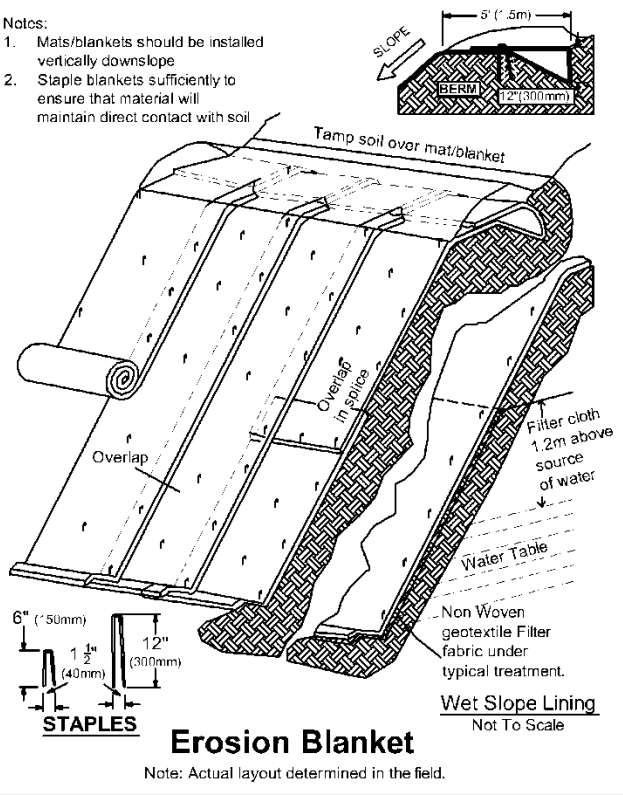

Notes:

1. Silt fence shall be placed level along slope contours to maximize ponding efficiency with the ends curved uphill to improve ability to retain water.
2. Inspect and repair fence after each storm event and remove sediment when accumulation reaches 1/3 of the barrier height.
3. Removed sediment shall be deposited to an area that will not contribute sediment off-site and can be permanently stabilized

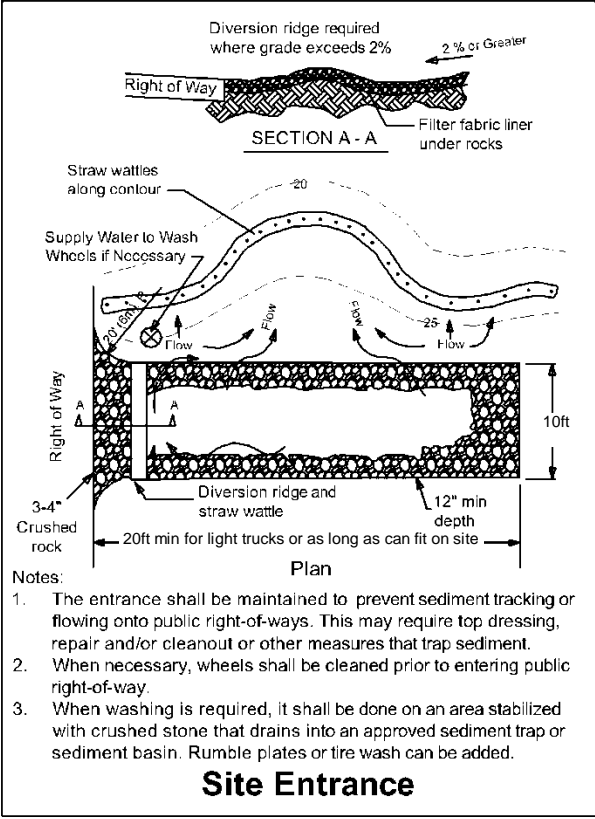

Notes:

1. The entrance shall be maintained to prevent sediment tracking or flowing onto public right-of-ways. This may require top dressing, repair and/or cleanout or other measures that trap sediment.
2. When necessary, wheels shall be cleaned prior to entering public right-of-way.
3. When washing is required, it shall be done on an area stabilized with crushed stone that drains into an approved sediment trap or sediment basin. Rumble plates or tire wash can be added.

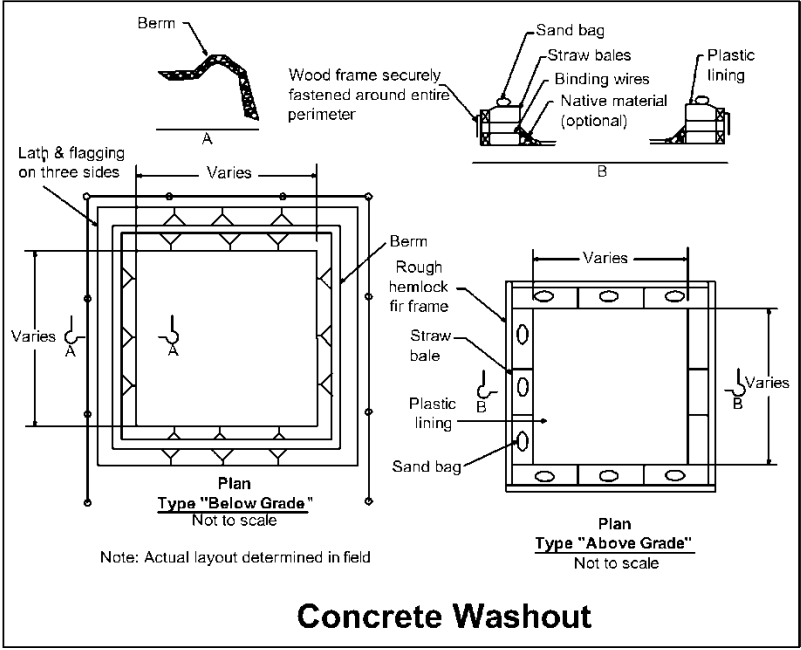



CITY OF TRACY Trench Dewatering BMPs



Protect rivers and the Delta: Keep Sediments and
Contaminated Water out of the Storm Drain System

CITY OF TRACY STORMWATER MANAGEMENT PROGRAM Best Management Practices (BMPs) for TRENCH DEWATERING

Requirements for Dewatering Discharges from Minor Street Excavations

- The Federal Clean Water Act, the California Water Code, and local ordinances **prohibit** non-stormwater discharges to the storm drain system.
- Non-stormwater discharges include water that is actually or potentially contaminated with any pollutant, including, but not limited to, sewage, grease, drilling mud and oil.
- Uncontaminated pumped groundwater or accumulated rainwater may be discharged to the storm drain system but must be managed to minimize sediment reaching storm drains and ensure downstream creeks, wetlands, and the Delta are not polluted.
- The storm drain system includes streets, gutters, storm drain inlets, ditches, creeks, and wetlands.

IF YOUR SITE OR PROJECT REQUIRES DEWATERING, CONTACT THE CITY OF TRACY STORMWATER MANAGEMENT BEFORE DISCHARGING WATER TO THE STORM DRAIN SYSTEM.

As necessary, local municipal staff will determine whether flows from dewatering a particular excavation may be discharged to the storm drain system and what measures must be taken to reduce sediment in the discharge.

Depending on circumstances, holders of encroachment or building permits may be directed to use one or more of the following measures:

- Avoid the discharge. Disperse pumped water to a level dirt or landscaped area to allow infiltration or use for dust control. Be sure to prevent damage to landscaping.
- Build a sediment trap (temporary basin formed by excavation or earthen embankment across a low drainage area to detain sediment-laden runoff and allow sediment to settle out before discharging).
- Use a mobile weir tank, dewatering tank, or sand filter (follow vendor instructions).
- At minimum, use a gravity bag filter (dewatering bag) or similar filtration device (follow vendor instructions).

Odors, discoloration, or an oily sheen can indicate contaminants in the water. Dewatering discharges containing contaminants may need to be captured and treated or hauled to a suitable disposal site.

Some dewatering discharges require a National Pollutant Discharge Elimination System (NPDES) permit from the Central Valley Regional Water Quality Control Board (RWQCB). For more information, call the RWQCB (916) 464-3291 or visit their website: http://www.waterboards.ca.gov/centralvalley/help/business_help/permit2.shtml



Protect rivers and the Delta: Keep Sediments and Contaminated Water out of the Storm Drain System

San Joaquin County Local Municipal Stormwater Management Programs

City of Manteca
209-456-8400

City of Lodi
209-333-6740

San Joaquin County
209-468-3055

City of Lathrop
209-941-7290



References:

California State Water Resources Control Board, Municipal Phase II Stormwater NPDES Permit CASQA, Dewatering Operations: <http://www.cabmphandbooks.com/Documents/Construction/NS-2.pdf>
City of Tracy Stormwater Management, <http://www.ci.tracy.ca.us/?navId=1679>
Caltrans, Construction Site Best Management Practices Manual, Dewatering Operations NS-2 (<http://www.dot.ca.gov/hq/construc/stormwater/NS02Update.doc>)

City of Tracy Stormwater Management Program
3900 Holly Drive ▪ Tracy, CA 95304 ▪ 209-831-6333
www.CityofTracy.org